

Technical Data Manual

Model Nos. and pricing: see Price List



Vitocell 100-V CVWC

Single coil, indirect-fired domestic hot water storage tank
53 USG (200 L), 66 USG (250 L), 79 USG (300 L) capacity

VITOCCELL 100-V



Product may not be exactly as shown

Vertical indirect-fired domestic hot water (DHW) storage tank of steel construction, with enamel finish.

 CAUTION
This tank version is not suitable for steam heating applications.

RECOGNIZED COMPONENT



Intertek
5029970

Conforms to UL STD 174
Certified to CSA STD C22.2#110

Benefits

Hygienic, convenient and economical Domestic hot water (DHW) heating with DHW tanks – vertical version

Benefits at a glance:

- Corrosion-resistant tank offering a long service life.
- The tank stays hygienic and requires only minimum service.
- The entire water content is heated by a tubular heat exchanger surface which extends to the bottom of the tank.
- The positioning of the tubular heat exchanger coil in conjunction with the DCW diffuser further ensures that 82% to 97% of the tank volume can be drawn at constant water temperature.
- The heat exchanger coil is self-venting towards the top and self-draining towards the bottom, therefore not susceptible to reduced heat transfer due to air lock or deposits.
- Standby losses minimized by highly effective HCFC free foam.
- Easy transport into mechanical room due to low weight and compact construction.
- In conformance with CSA Low Lead Content Certification Program; including US Safe Drinking Water Act, NSF/ANSI 372 as well as other applicable US State requirements.

Cross Section



Legend

- 1** Impressed current anode
- 2** Ceraprotect enamel lined steel shell
- 3** Foam in place tank insulation
- 4** Self venting heat exchanger coil with large heating surface area to maximize heat transfer
- 5** Inspection and clean-out port

Product may not be exactly as shown

Technical Data Vitocell 100-V CVWC 53 USG (200 L)

For domestic hot water heating applications which utilize modulating and low temperature hot water heating boilers and the Vitocal 100-AW AM2Vseries.

Storage capacity	USG (L)	53 (200)
Insulation		PUR Foam
Heating Supply flow rate for the recovery rates stated	GPM (m ³ /h)	11.9 (2.7)
Recovery rates with a rise of the domestic hot water from 50 to 113°F (10 to 45°C) and heating water supply temperature of:	194°F (90°C) MBH (kW)	215 (63)
	GPH (L/h)	407 (1541)
	176°F (80°C) MBH (kW)	181 (53)
	GPH (L/h)	339 (1285)
	158°F (70°C) MBH (kW)	144 (42)
	GPH (L/h)	270 (1024)
	149°F (65°C) MBH (kW)	124 (36.2)
	GPH (L/h)	235 (891)
	140°F (60°C) MBH (kW)	105 (30.6)
	GPH (L/h)	199 (753)
	131°F (55°C) MBH (kW)	85 (24.7)
	GPH (L/h)	161 (608)
	122°F (50°C) MBH (kW)	62 (18.1)
	GPH (L/h)	118 (446)
with a rise of the domestic hot water from 50 to 122°F (10 to 50°C) and heating water supply temperature of:	194°F (90°C) MBH (kW)	205 (60)
	GPH (L/h)	339 (1285)
	176°F (80°C) MBH (kW)	171 (50)
	GPH (L/h)	279 (1057)
	158°F (70°C) MBH (kW)	134 (39)
	GPH (L/h)	217 (823)
	149°F (65°C) MBH (kW)	111 (32.5)
	GPH (L/h)	185 (700)
	140°F (60°C) MBH (kW)	90 (26.5)
	GPH (L/h)	151 (570)
	131°F (55°C) MBH (kW)	67 (19.6)
	GPH (L/h)	112 (423)
with a rise of the domestic hot water from 50 to 131°F (10 to 55°C) and heating water supply temperature of:	194°F (90°C) MBH (kW)	195 (57)
	GPH (L/h)	286 (1083)
	176°F (80°C) MBH (kW)	157 (46)
	GPH (L/h)	231 (876)
	158°F (70°C) MBH (kW)	120 (35)
	GPH (L/h)	173 (658)
	149°F (65°C) MBH (kW)	96 (28.2)
	GPH (L/h)	142 (539)
	140°F (60°C) MBH (kW)	72 (21.1)
	GPH (L/h)	107 (405)
with a rise of the domestic hot water from 50 to 140°F (10 to 60°C) and heating water supply temperature of:	194°F (90°C) MBH (kW)	185 (54)
	GPH (L/h)	242 (918)
	176°F (80°C) MBH (kW)	147 (43)
	GPH (L/h)	191 (725)
	158°F (70°C) MBH (kW)	103 (30)
	GPH (L/h)	135 (514)
	149°F (65°C) MBH (kW)	78 (22.6)
	GPH (L/h)	103 (389)

Technical Data Vitocell 100-V CVWC 53 USG (200 L)

Storage tank draw volume			
at 113°F (45°C) without reheating with a tank temperature of:	113°F (45°C)	USG (L)	37 (140)
	122°F (50°C)	USG (L)	53 (203)
	131°F (55°C)	USG (L)	70 (266)
	140°F (60°C)	USG (L)	87 (330)
at 131°F (55°C) without reheating with a tank temperature of:	131°F (55°C)	USG (L)	37 (140)
	140°F (60°C)	USG (L)	53 (203)
Heating time (in minutes) when connecting a heat pump with the specified nominal heat output (A7/W35) for a domestic hot water temperature rise of 50 to 113°F (10 to 45°C) and a heating supply water temperature of 140°F (60°C)	20.5 MBH (6 kW)		86
	27.3 MBH (8 kW)		65
	34.1 MBH (10 kW)		52
	44.4 MBH (13 kW)		40
	58.0 MBH (17 kW)		30
for a domestic hot water temperature rise of 50 to 122°F (10 to 50°C) and a heating supply water temperature of 140°F (60°C)	20.4 MBH (6 kW)		98
	27.3 MBH (8 kW)		74
	34.1 MBH (10 kW)		59
	44.4 MBH (13 kW)		45
	58.0 MBH (17 kW)		35
Maximum Operating Temperature			
Heating System Supply			248°F (120°C)
Domestic Hot Water			180°F (82°C)
Standby heat loss			
q _{B,S} at 81°F (45 K) temperature differential	MBTU/24h (kWh/24h)		4.2 (1.22)
Dimensions*¹			
Overall length		in. (mm)	26- ¹ / ₄ (668)
Overall width		in. (mm)	28- ¹ / ₄ (714)
Overall height* ²		in. (mm)	48- ¹ / ₂ (1229)
Tilt height		in. (mm)	53- ³ / ₄ (1365)
Weight			
Tank with insulation		lbs (kg)	214 (97)
Heat exchanger surface area			ft ² (m ²)
Heat exchanger surface area			21.5 (2.0)
Heating water content			
(heat exchanger pipe coil)			USG (L)
Heating water content			3.83 (14.5)
Connections*³			
Heating water supply/return	Ø in. (male NPT thread)		1
Domestic cold/hot water	Ø in. (male NPT thread)		1
Temp. and press. relief valve	Ø in. (male NPT thread)		1
Recirculation	Ø in. (male NPT thread)		1

*¹ For additional dimensions, see illustrations and table on "Tank Dimensions Vitocell 100-V CVWC 53 USG (200 L)" on page 10.

*² Adjustable feet can be adjusted up to 1-¹/₄ in. (35 mm).

*³ With installation of supplied adaptors

For information regarding other Viessmann System Technology componentry, please reference documentation of the respective product.

Technical Data Vitocell 100-V CVWC 66 USG (250 L)

For domestic hot water heating applications which utilize modulating and low temperature hot water heating boilers and the Vitocal 100-AW AM2Vseries.

Storage capacity	USG (L)	66 (250)	
Insulation		PUR Foam	
Heating Supply flow rate for the recovery rates stated	GPM (m ³ /h)	11.9 (2.7)	
Recovery rates with a rise of the domestic hot water from 50 to 113°F (10 to 45°C) and heating water supply temperature of:	194°F (90°C) MBH (kW)	239 (70)	
	GPH (L/h)	450 (1705)	
	176°F (80°C) MBH (kW)	198 (58)	
	GPH (L/h)	375 (1423)	
	158°F (70°C) MBH (kW)	161 (47)	
	GPH (L/h)	299 (1135)	
	149°F (65°C) MBH (kW)	137 (40.1)	
	GPH (L/h)	261 (988)	
	140°F (60°C) MBH (kW)	116 (34.0)	
	GPH (L/h)	221 (836)	
	131°F (55°C) MBH (kW)	94 (27.4)	
	GPH (L/h)	178 (675)	
	122°F (50°C) MBH (kW)	69 (20.2)	
	GPH (L/h)	131 (496)	
with a rise of the domestic hot water from 50 to 122°F (10 to 50°C) and heating water supply temperature of:	194°F (90°C) MBH (kW)	229 (67)	
	GPH (L/h)	375 (1423)	
	176°F (80°C) MBH (kW)	188 (55)	
	GPH (L/h)	309 (1172)	
	158°F (70°C) MBH (kW)	147 (43)	
	GPH (L/h)	240 (912)	
	149°F (65°C) MBH (kW)	123 (36.1)	
	GPH (L/h)	205 (777)	
	140°F (60°C) MBH (kW)	100 (29.4)	
	GPH (L/h)	167 (633)	
	131°F (55°C) MBH (kW)	75 (21.9)	
	GPH (L/h)	124 (471)	
	with a rise of the domestic hot water from 50 to 131°F (10 to 55°C) and heating water supply temperature of:	194°F (90°C) MBH (kW)	215 (63)
		GPH (L/h)	317 (1200)
176°F (80°C) MBH (kW)		175 (51)	
GPH (L/h)		256 (971)	
158°F (70°C) MBH (kW)		134 (39)	
GPH (L/h)		192 (730)	
149°F (65°C) MBH (kW)		107 (31.3)	
GPH (L/h)		158 (599)	
140°F (60°C) MBH (kW)		80 (23.5)	
GPH (L/h)		118 (450)	
with a rise of the domestic hot water from 50 to 140°F (10 to 60°C) and heating water supply temperature of:		194°F (90°C) MBH (kW)	205 (60)
		GPH (L/h)	268 (1017)
		176°F (80°C) MBH (kW)	161 (47)
		GPH (L/h)	212 (804)
	158°F (70°C) MBH (kW)	117 (34)	
	GPH (L/h)	151 (572)	
	149°F (65°C) MBH (kW)	86 (25.2)	
	GPH (L/h)	114 (433)	

Technical Data Vitocell 100-V CVWC 66 USG (250 L)

Storage tank draw volume			
at 113°F (45°C) without reheating with a tank temperature of:	113°F (45°C)	USG (L)	46 (175)
	122°F (50°C)	USG (L)	67 (254)
	131°F (55°C)	USG (L)	88 (333)
	140°F (60°C)	USG (L)	109 (412)
at 131°F (55°C) without reheating with a tank temperature of:	131°F (55°C)	USG (L)	46 (175)
	140°F (60°C)	USG (L)	67 (254)
Heating time (in minutes) when connecting a heat pump with the specified nominal heat output (A7/W35) for a domestic hot water temperature rise of 50 to 113°F (10 to 45°C) and a heating supply water temperature of 140°F (60°C)	20.4 MBH (6 kW)		108
	27.3 MBH (8 kW)		81
	34.1 MBH (10 kW)		65
	44.4 MBH (13 kW)		50
	58.0 MBH (17 kW)		38
for a domestic hot water temperature rise of 50 to 122°F (10 to 50°C) and a heating supply water temperature of 140°F (60°C)	20.4 MBH (6 kW)		123
	27.3 MBH (8 kW)		92
	34.1 MBH (10 kW)		74
	44.4 MBH (13 kW)		57
	58.0 MBH (17 kW)		43
Maximum Operating Temperature			
Heating System Supply			248°F (120°C)
Domestic Hot Water			180°F (82°C)
Standby heat loss			
q _{B,S} at 81°F (45 K) temperature differential	MBTU/24h (kWh/24h)		4.5 (1.31)
Dimensions*¹			
Overall length	in. (mm)		26-¼ (668)
Overall width	in. (mm)		28-¼ (714)
Overall height* ²	in. (mm)		56-½ (1430)
Tilt height	in. (mm)		61 (1548)
Weight			
Tank with insulation	lbs (kg)		245 (111)
Heat exchanger surface area		ft ² (m ²)	24.2 (2.25)
Heating water content			
(heat exchanger pipe coil)	USG (L)		4.36 (16.5)
Connections*³			
Heating water supply/return	Ø in. (male NPT thread)		1
Domestic cold/hot water	Ø in. (male NPT thread)		1
Temp. and press. relief valve	Ø in. (male NPT thread)		1
Recirculation	Ø in. (male NPT thread)		1

*¹ For additional dimensions, see illustrations and table on "Tank Dimensions Vitocell 100-V CVWC 66 and 79 USG (250 and 300 L)" on page 11

*² Adjustable feet can be adjusted up to 1-¼ in. (35 mm).

*³ With installation of supplied adaptors

For information regarding other Viessmann System Technology componentry, please reference documentation of the respective product.

Technical Data Vitocell 100-V CVWC 79 USG (300 L)

For domestic hot water heating applications which utilize modulating and low temperature hot water heating boilers and the Vitocal 100-AW AM2Vseries.

Storage capacity	USG (L)	79 (300)
Insulation		PUR Foam
Heating Supply flow rate for the recovery rates stated	GPM (m ³ /h)	11.9 (2.7)
Recovery rates with a rise of the domestic hot water from 50 to 113°F (10 to 45°C) and heating water supply temperature of:	194°F (90°C) MBH (kW)	260 (76)
	GPH (L/h)	492 (1863)
	176°F (80°C) MBH (kW)	219 (64)
	GPH (L/h)	411 (1556)
	158°F (70°C) MBH (kW)	175 (51)
	GPH (L/h)	328 (1242)
	149°F (65°C) MBH (kW)	150 (43.9)
	GPH (L/h)	286 (1081)
	140°F (60°C) MBH (kW)	127 (37.2)
	GPH (L/h)	242 (916)
	131°F (55°C) MBH (kW)	103 (30.1)
	GPH (L/h)	196 (741)
	122°F (50°C) MBH (kW)	76 (22.2)
	GPH (L/h)	144 (545)
with a rise of the domestic hot water from 50 to 122°F (10 to 50°C) and heating water supply temperature of:	194°F (90°C) MBH (kW)	250 (73)
	GPH (L/h)	411 (1556)
	176°F (80°C) MBH (kW)	205 (60)
	GPH (L/h)	338 (1282)
	158°F (70°C) MBH (kW)	161 (47)
	GPH (L/h)	263 (999)
	149°F (65°C) MBH (kW)	135 (39.5)
	GPH (L/h)	225 (851)
	140°F (60°C) MBH (kW)	110 (32.3)
	GPH (L/h)	184 (695)
	131°F (55°C) MBH (kW)	82 (24.0)
	GPH (L/h)	137 (517)
with a rise of the domestic hot water from 50 to 131°F (10 to 55°C) and heating water supply temperature of:	194°F (90°C) MBH (kW)	236 (69)
	GPH (L/h)	346 (1313)
	176°F (80°C) MBH (kW)	192 (56)
	GPH (L/h)	280 (1063)
	158°F (70°C) MBH (kW)	144 (42)
	GPH (L/h)	211 (801)
	149°F (65°C) MBH (kW)	118 (34.4)
	GPH (L/h)	174 (658)
	140°F (60°C) MBH (kW)	89 (25.9)
	GPH (L/h)	131 (495)
with a rise of the domestic hot water from 50 to 140°F (10 to 60°C) and heating water supply temperature of:	194°F (90°C) MBH (kW)	222 (65)
	GPH (L/h)	294 (1114)
	176°F (80°C) MBH (kW)	178 (52)
	GPH (L/h)	233 (882)
	158°F (70°C) MBH (kW)	127 (37)
	GPH (L/h)	165 (628)
	149°F (65°C) MBH (kW)	95 (27.7)
	GPH (L/h)	126 (476)

Technical Data Vitocell 100-V CVWC 79 USG (300 L)

Storage tank draw volume			
at 113°F (45°C) without reheating with a tank temperature of:	113°F (45°C)	USG (L)	55 (210)
	122°F (50°C)	USG (L)	80 (305)
	131°F (55°C)	USG (L)	106 (400)
	140°F (60°C)	USG (L)	131 (495)
at 131°F (55°C) without reheating with a tank temperature of:	131°F (55°C)	USG (L)	55 (210)
	140°F (60°C)	USG (L)	81 (305)
Heating time (in minutes) when connecting a heat pump with the specified nominal heat output (A7/W35) for a domestic hot water temperature rise of 50 to 113°F (10 to 45°C) and a heating supply water temperature of 140°F (60°C)	20.4 MBH (6 kW)		129
	27.3 MBH (8 kW)		97
	34.1 MBH (10 kW)		78
	44.4 MBH (13 kW)		60
	58.0 MBH (17 kW)		46
for a domestic hot water temperature rise of 50 to 122°F (10 to 50°C) and a heating supply water temperature of 140°F (60°C)	20.4 MBH (6 kW)		147
	27.3 MBH (8 kW)		111
	34.1 MBH (10 kW)		89
	44.4 MBH (13 kW)		68
	58.0 MBH (17 kW)		52
Maximum Operating Temperature			
Heating System Supply			248°F (120°C)
Domestic Hot Water			180°F (82°C)
Standby heat loss			
qB,S at 81°F (45 K) temperature differential	MBTU/24h (kWh/24h)		5.3 (1.54)
Dimensions*¹			
Overall length		in. (mm)	26-¼ (668)
Overall width		in. (mm)	28-¼ (714)
Overall height* ²		in. (mm)	67 (1697)
Tilt height		in. (mm)	70-½ (1790)
Weight			
Tank with insulation		lbs (kg)	278 (126)
Heat exchanger surface area			ft ² (m ²)
Heating water content (heat exchanger pipe coil)			USG (L)
			4.76 (18)
Connections*³			
Heating water supply/return	Ø in. (male NPT thread)		1
Domestic cold/hot water	Ø in. (male NPT thread)		1
Temp. and press. relief valve	Ø in. (male NPT thread)		1
Recirculation	Ø in. (male NPT thread)		1

*¹ For additional dimensions, see illustrations and table on “Tank Dimensions Vitocell 100-V CVWC 66 and 79 USG (250 and 300 L)” on page 11

*² Adjustable feet can be adjusted up to 1-¼ in. (35 mm).

*³ With installation of supplied adaptors

For information regarding other Viessmann System Technology componentry, please reference documentation of the respective product.

Tank Dimensions Vitocell 100-V CVWC 53 USG (200 L)

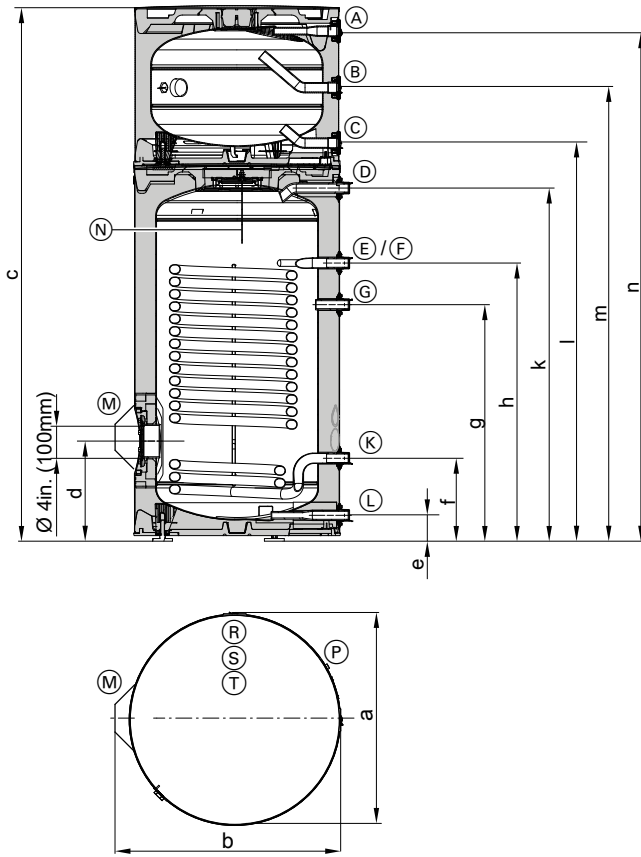

Legend

- Ⓐ 1 Inch NPT female thread, heating supply from backup heat generator/Ⓔ 1 Inch NPT female thread, system supply, highest point/ventilation
- Ⓑ 1 Inch NPT female thread, supply from primary heat/cool generator/Ⓢ 1 Inch NPT female thread, return to backup heat generator
- Ⓒ 1 Inch NPT female thread, return to primary heat/cool generator, lowest point/drain/Ⓣ 1 Inch NPT female thread, system return
- Ⓓ Domestic Hot Water
- Ⓔ Domestic Hot Water Tank Sensor Well
- Ⓕ Heating Water Supply
- Ⓖ Domestic Hot Water Recirculation Tapping
- Ⓚ Heating Water Return
- Ⓛ Domestic Cold Water
- Ⓜ Cleanout and Inspection Port
- Ⓝ Impressed Current Anode
- Ⓟ Electronic Unit for Impressed Current Anode

Dimensions in. (mm)

	CVWC 53
a	26-1/4 (668)
b	28-1/4 (714)
c	68 (1728)
d	12-3/4 (323)
e	3-1/4 (83)
f	10-1/2 (268)
g	31 (788)
h	35-1/2 (898)
k	45 (1140)
l	50-1/4 (1277)
m	57-1/2 (1457)
n	64-3/4 (1641)

Adjustable feet can be adjusted up to 1-1/4 in. (35 mm).

Tank Dimensions Vitocell 100-V CVWC 66 and 79 USG (250 and 300 L)

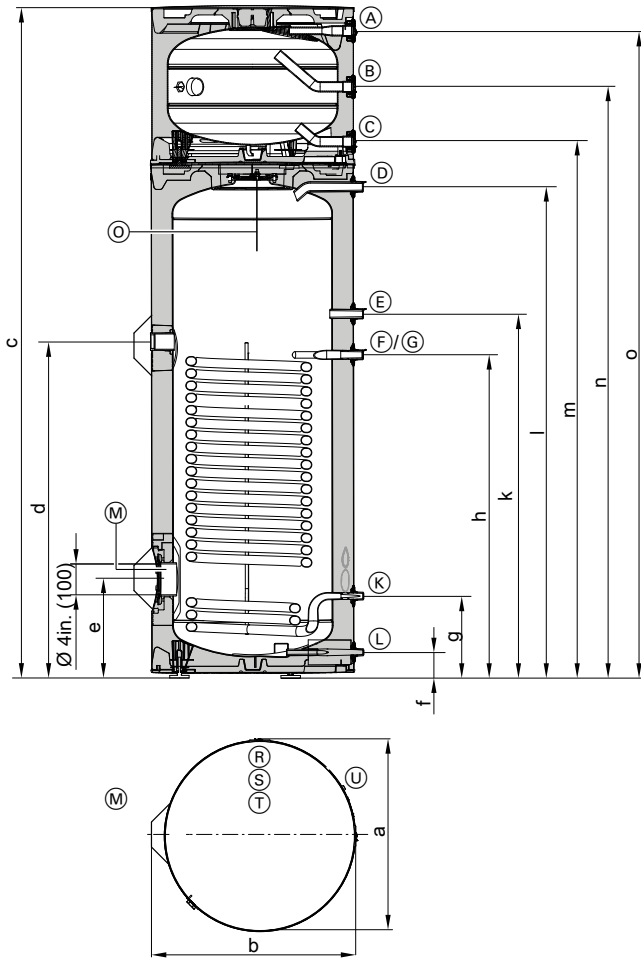

Legend

- Ⓐ 1 Inch NPT female thread, heating supply from backup heat generator/Ⓡ 1 Inch NPT female thread, system supply, highest point/ventilation
- Ⓑ 1 Inch NPT female thread, supply from primary heat/cool generator/Ⓢ 1 Inch NPT female thread, return to backup heat generator
- Ⓒ 1 Inch NPT female thread, return to primary heat/cool generator, lowest point/drain/Ⓣ 1 Inch NPT female thread, system return
- Ⓓ Domestic Hot Water
- Ⓔ Domestic Hot Water Recirculation Tapping
- Ⓕ Heating Water Supply
- Ⓖ Domestic Hot Water Tank Sensor Well
- Ⓚ Heating Water Return
- Ⓛ Domestic Cold Water
- Ⓜ Cleanout and Inspection Port
- Ⓞ Impressed Current Anode
- Ⓤ Electronic Unit for Impressed Current Anode

Dimensions in. (mm)

	CVWC 66	CVWC 79
a	26-1/4 (668)	26-1/4 (668)
b	28-1/4 (714)	28-1/4 (714)
c	76 (1929)	86-1/2 (2196)
d	40-1/4 (1022)	43-1/2 (1101)
e	12-3/4 (323)	12-3/4 (323)
f	3-1/4 (83)	3-1/4 (83)
g	10-1/2 (268)	10-1/2 (268)
h	38-1/2 (978)	41-3/4 (1057)
k	34 (866)	46 (1167)
l	53 (1345)	63-1/4 (1607)
m	58-3/4 (1488)	69 (1754)
n	65-3/4 (1667)	76-1/4 (1934)
o	73 (1851)	83-1/2 (2118)

Adjustable feet can be adjusted up to 1-1/4 in. (35 mm).

Vitocell 100-E MSCA 20 USG Buffer Tank

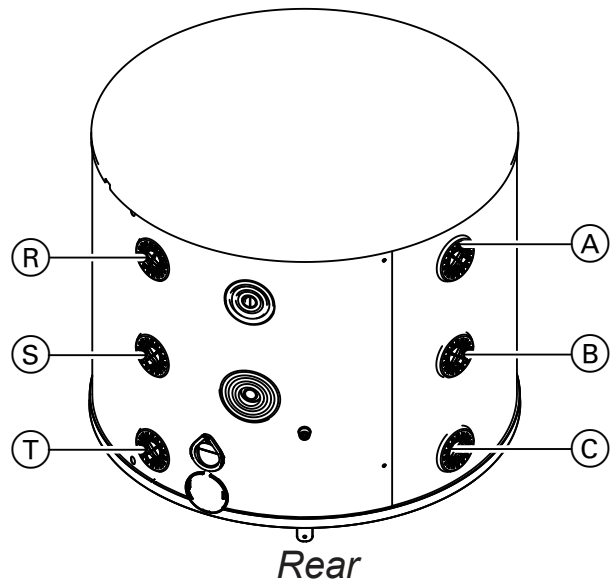
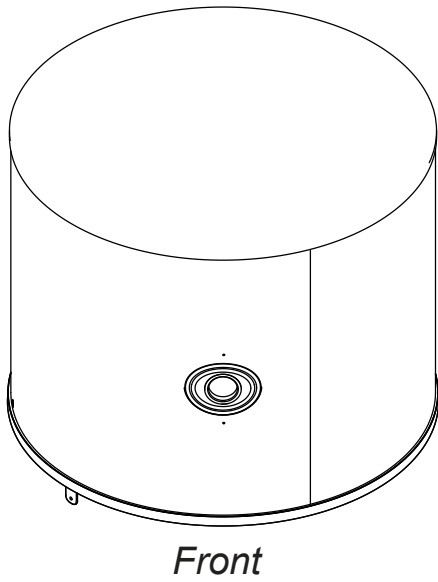

Legend

- Ⓐ 1 Inch NPT female thread, heating supply from backup heat generator
- Ⓑ 1 Inch NPT female thread, supply from primary heat/cool generator
- Ⓒ 1 Inch NPT female thread, return to primary heat/cool generator, lowest point/drain
- Ⓓ 1 Inch NPT female thread, system supply, highest point/ventilation
- Ⓔ 1 Inch NPT female thread, return to backup heat generator
- Ⓕ 1 Inch NPT female thread, system return



Refer to Technical Data Manual for the Vitocell 100-E MSCA for additional information.

Pressure Drop

Vitocell 100-V CVWC 53 USG (200L)

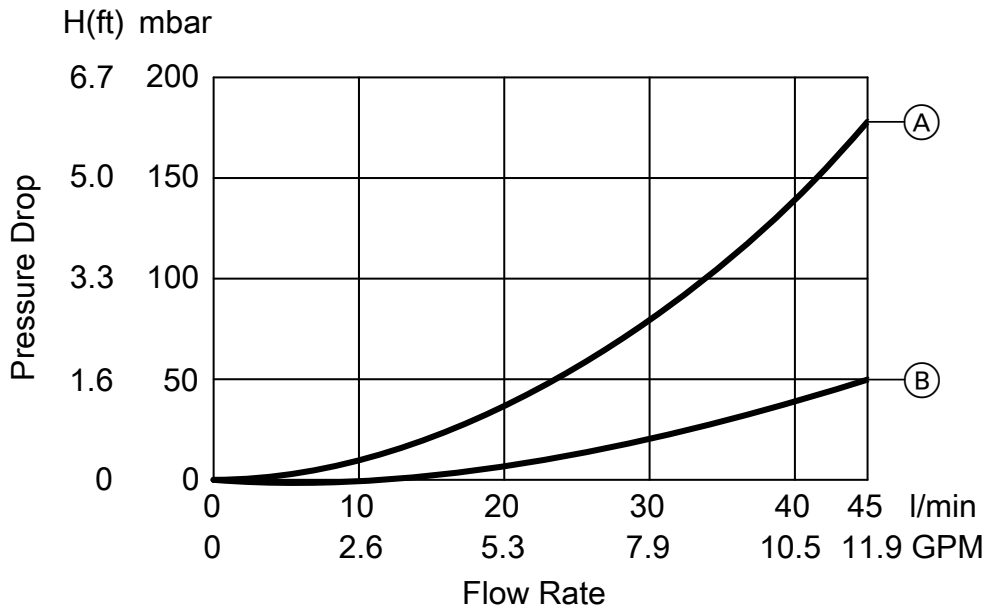

Legend

- (A) Heating System Water
- (B) DHW

Pressure Drop

Vitocell 100-V CVWC 66 USG (250L)

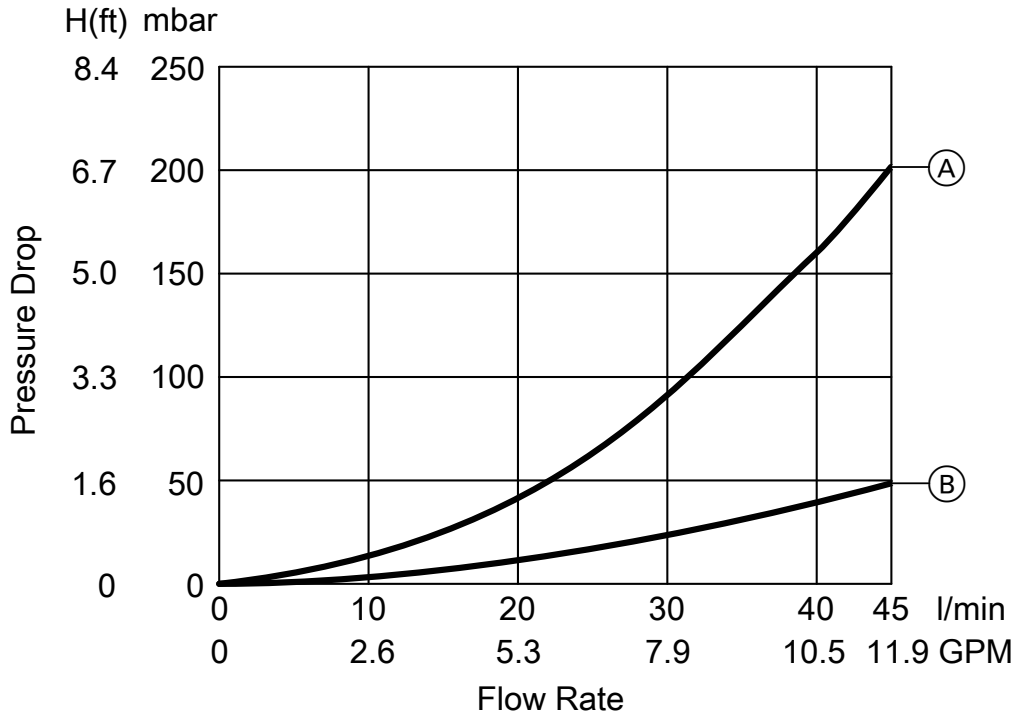

Legend

- Ⓐ Heating System Water
- Ⓑ DHW

Pressure Drop

Vitocell 100-V CVWC 79 USG (300L)

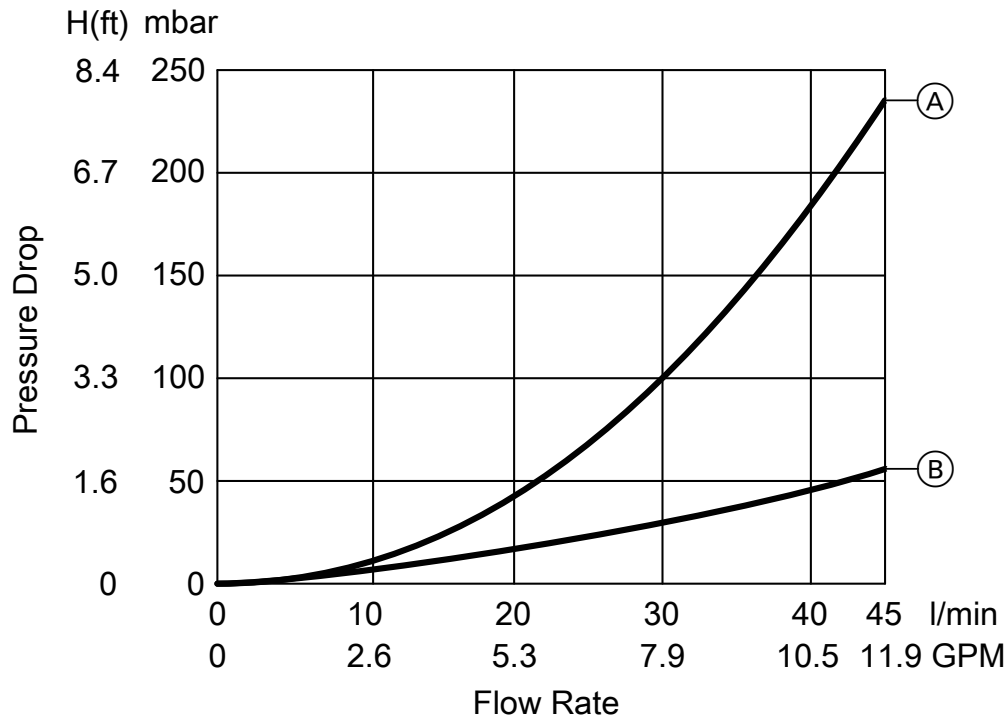

Legend

- Ⓐ Heating System Water
- Ⓑ DHW

Standard Equipment

Vitocell 100-V, CVWC 53 USG (200 L) capacity
Steel DHW tank with enamel coating.

- Integral welded sensor well for tank temperature sensor/temperature controller
- Temperature and pressure relief valve
- Installation fittings
- Technical literature set
- Adjustable feet
- Fitted thermal insulation
- Color of the epoxy-coated sheet steel casing: Vitopearlwhite.

Vitocell 100-V, CVWC 66 USG (250 L) capacity
Steel DHW tank with enamel coating.

- Integral welded sensor well for tank temperature sensor/temperature controller
- Temperature and pressure relief valve
- Installation fittings
- Technical literature set
- Adjustable feet
- Fitted thermal insulation
- Color of the epoxy-coated sheet steel casing: Vitopearlwhite.

Vitocell 100-V, CVWC 79 USG (300 L) capacity
Steel DHW tank with enamel coating.

- Integral welded sensor well for tank temperature sensor/temperature controller
- Temperature and pressure relief valve
- Installation fittings
- Technical literature set
- Adjustable feet
- Fitted thermal insulation
- Color of the epoxy-coated sheet steel casing: Vitopearlwhite.

System Design Guidelines

Domestic hot water connections

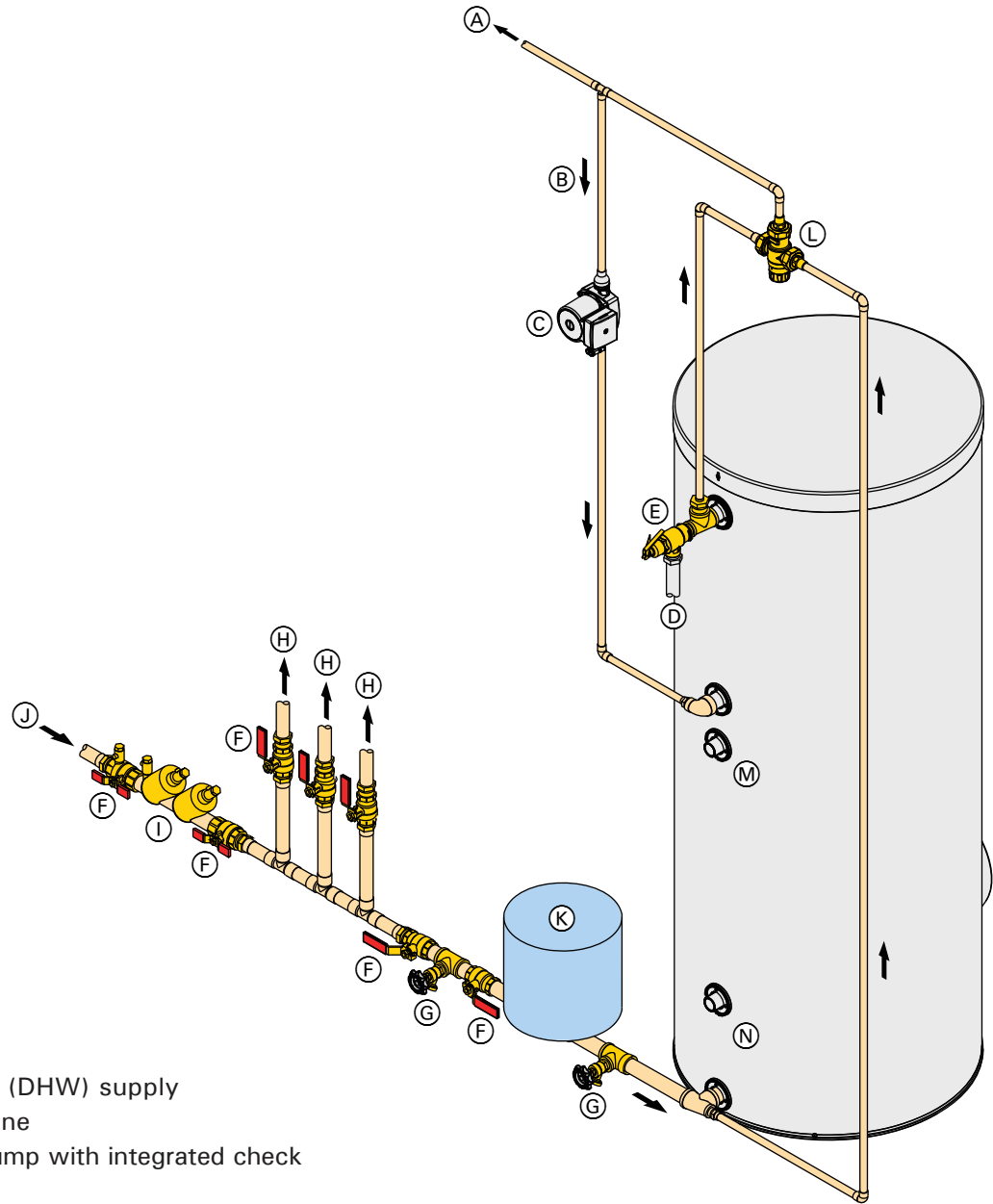

Legend

- (A) Domestic hot water (DHW) supply
- (B) DHW recirculation line
- (C) DHW recirculation pump with integrated check valve
- (D) Discharge pipe
- (E) Pressure and temperature relief valve
- (F) Shut-off valves
- (G) Drain
- (H) Domestic cold water (DCW) supply lines
- (I) Backflow preventer
- (J) DCW inlet
- (K) Precharged expansion tank (required where backflow preventer is installed; check local plumbing codes and requirements)
- (L) Thermostatic mixing valve/anti-scald valve
- (M) Heat pump supply
- (N) Heat pump return

⚠ IMPORTANT
 This is a simplified conceptual drawing only! Piping and necessary componentry must be field verified. Proper installation and functionality in the field is the responsibility of the heating contractor.

Additional System Information

Sensors

The sensor clamps are to be used for control sensors to ensure maximum operational safety. For solar heating systems, Viessmann recommends placement of the DHW tank temperature sensor in the solar collector return. This requires a brass elbow with the sensor well.

WARNING

To ensure optimum, safe operation, the stainless steel well must be used. The well diameter is large enough to accommodate a wide variety of sensing bulbs. Always use spring clip to ensure proper contact of capillary bulb against the stainless steel well for proper sensing/heat transfer!

Heating water supply temperature over 248°F (120°C)

For these operating conditions, an approved high limit must be installed to limit the domestic hot water temperature to 180°F (82°C) in the tank.

Temperature and pressure relief valve

A 150 psi temperature and pressure relief valve (T&P relief valve) is supplied with the tank. The heating contractor must install the valve on each tank in a method meeting code requirements. If local codes require a different relief valve, substitute the manufacturer's supplied valve. Maximum operating pressure is 150 psig.

The T&P relief valve supplied with the tank is tested under ANSI Z21.22 Code for Relief Valves and Automatic Gas Shut-off Devices for Hot Water Supply Systems.

T&P Valve	150 psig
ASME pressure steam rating	see ratings marked on T&P valve
CSA temperature steam rating	205 MBH
Relief temperature	210°F (99°C)
Inlet thread	¾ in. male
Outlet thread	¾ in. female

Tempering valve

Ensure that temperature tempering valve(s) is installed if the domestic hot water storage tank temperature exceeds 140°F (60°C) to protect from scalding.

Consult plumbing codes and authorities for local requirements.

Installation of additional high limit temperature device(s)

WARNING

In a multiple-tank installation, it is recommended that an additional high limit temperature device be installed in the common domestic hot water supply header to the system. This safety device should be wired in series to the operating control of the tank battery. The setting on this additional high limit temperature device should be approximately 9°F (5°C) higher than the operating high limit.

Recirculation tapping

The recirculation tapping is on a separate tapping. Cap this opening if the tank is not installed with recirculation.

Backflow preventers

Where backflow preventers are required, a domestic water expansion tank installation is recommended in the cold water inlet piping before the cold water enters the Vitocell. For the backflow device, observe local plumbing codes and regulations.

Warranty consideration

Viessmann DHW tanks require that the water heated should be of drinking water quality and that any water treatment equipment in use must function correctly.

If the product has been improperly installed or misapplied by the installer, contractor or final user, Viessmann accepts no responsibility for damage howsoever caused and reserves the right to withdraw the product warranty. In order to qualify for product warranty, strict adherence to the installation and service manuals must be observed. In the event that components not approved by Viessmann are utilized, Viessmann reserves the right to withdraw all expressed or implied warranties without written notice.

The water to be heated with the Vitocell must be drinking (potable) water quality. If the tank is used to heat other media, the warranty will be null and void. Damage resulting from excessive pressure or temperature is clearly not the responsibility of Viessmann.

The amount of chloride and sulfate acceptable to the tank is limited. In areas where high concentrations of chloride and sulfate are present in drinking water, please consult Viessmann for directions.

For full warranty details, please read the product warranty sheet.

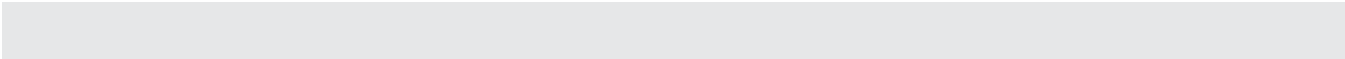

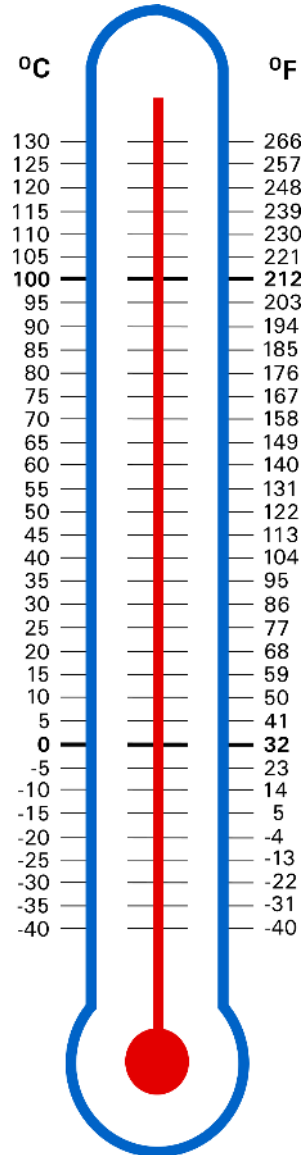

Technical information subject to change without notice.



Viessmann Manufacturing Company (U.S.) Inc.
45 Access Road
Warwick, Rhode Island · 02886 · USA
TechInfo Line 1-888-484-8643
1-800-288-0667 · Fax (401) 732-0590
www.viessmann-us.com · info@viessmann-us.com

Viessmann Manufacturing Company Inc.
750 McMurray Road
Waterloo, Ontario · N2V 2G5 · Canada
TechInfo Line 1-888-484-8643
1-800-387-7373 · Fax (519) 885-0887
www.viessmann.ca · info@viessmann.ca