

## Replacing the control unit

for Vitodens

---

### Safety instructions



**Please follow these safety instructions closely to prevent accidents and material losses.**

---

### Safety instructions explained



**Please note**

This symbol warns against the risk of material losses and environmental pollution.

When using gas as fuel, also close the main gas shut-off valve and safeguard against unauthorised reopening.

**Note**

*Details identified by the word "Note" contain additional information.*

Installation, initial start-up, inspection, maintenance and repairs must only be carried out by a competent person (heating engineer/installation contractor).

Repairing components which fulfil a safety function can compromise the safe operation of your heating system. For replacements, use only original spare parts supplied or approved by Viessmann.

Before working on the equipment/heating system, isolate the power supply (e.g. by removing a separate mains fuse or by means of a mains isolator) and safeguard against unauthorised reconnection.

## Installation information

### Application information

Part no., replacement control unit	Designation, replacement control unit	Designation, control unit to be replaced
7834 245	VBC 130-A04.100	VBC 130-A03.100 VBC 130-A03.200 VBC 130-A03.300 VBC 130-A03.400
7834 249	VBC 130-A04.500	VBC 130-A03.500
7834 250	VBC 131-A04.100	VBC 131-A03.100

### Calling up coding addresses

When replacing the control unit, some coding addresses have to be input again, subject to system configuration.

If possible, call up the following coding addresses prior to installation and record the set values in the table below.

Coding address	Set value
82 (gas type)	
06	
28	
31	
6F	



Boiler service instructions

### After installation

After installation, put these instructions with the boiler service instructions.

## Opening the Vitodens



Installation and service instructions

Switch off the power supply.

## Removing the programming unit and pivoting the control unit down

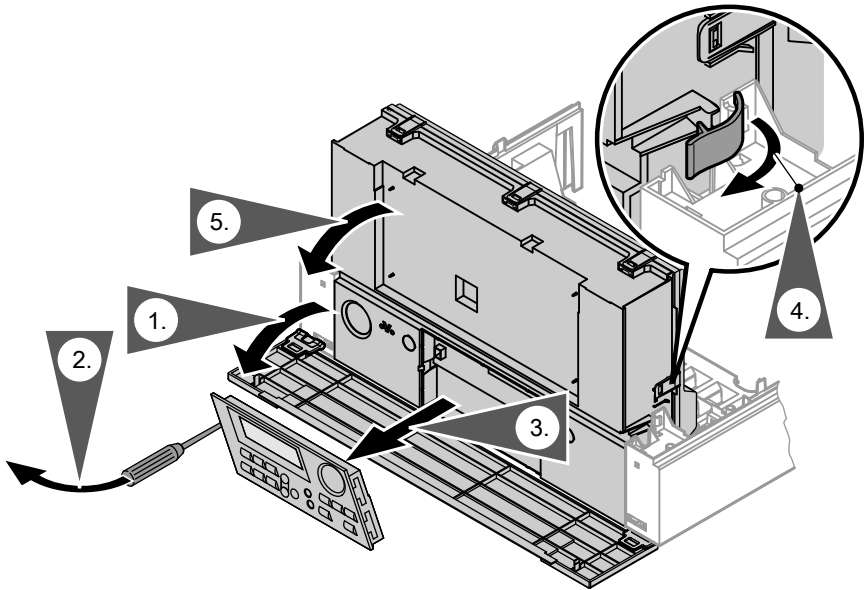

### **Please note**

Electronic assemblies can be damaged by electrostatic discharge.

Before beginning work, touch earthed objects, such as heating or water pipes, to discharge static loads.

## Replacing the control unit

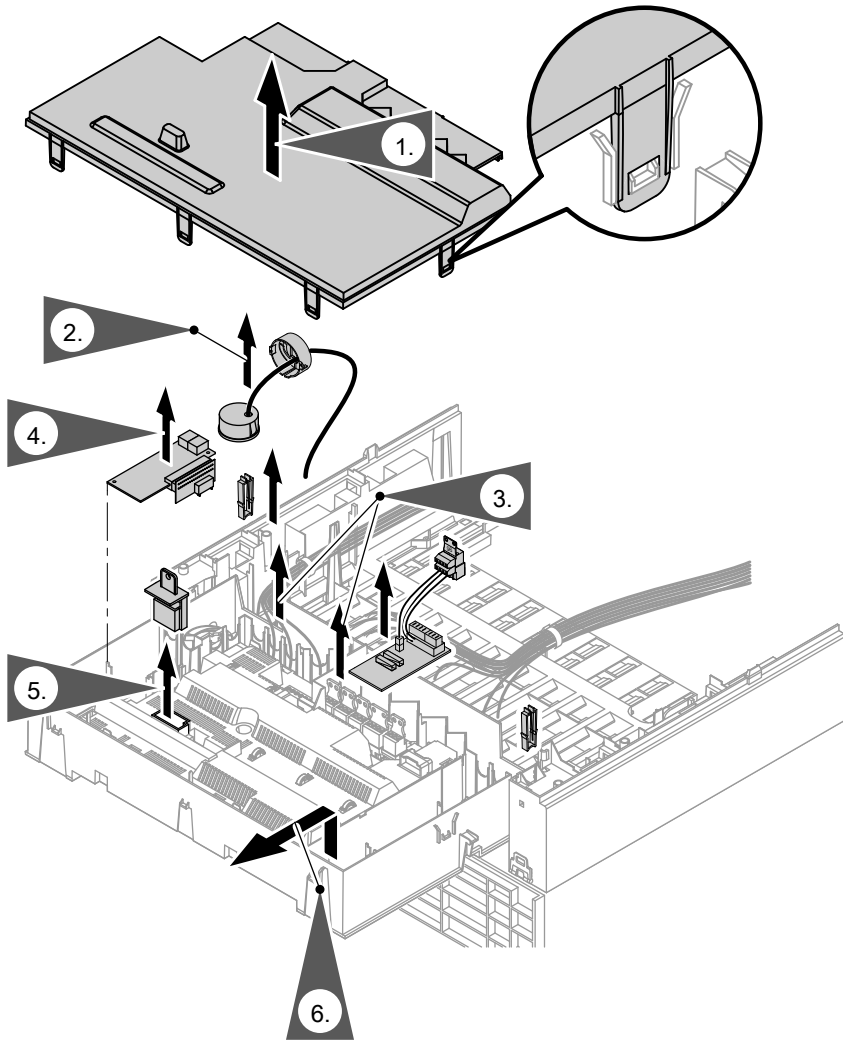

1. Open the control unit enclosure.

2. Undo the bayonet fitting and remove the pressure gauge.

3. Disconnect all plugs from the control unit.





## Replacing the control unit (cont.)

4. Remove all existing extensions (internal H1 or H2 extension, LON communication module, cascade module) and install them in the new control unit.
5. Remove the boiler coding card and insert it into the new control unit.
6. Release the locking tabs on the control unit and remove the unit.
7. Insert the new control unit into the control unit support and secure with the locking tabs.
8. Fit the pressure gauge and secure with the bayonet fitting.
9. Re-insert all plugs in the control unit.
10. Close the control unit enclosure and pivot up the control unit.
11. Insert the programming unit into the new control unit.

## Adjusting the control unit to the heating system

### Resetting codes to the factory setting

Press the following keys:

1.  +  simultaneously for approx. 2 s.
2.  "Stand. setting? Yes" is displayed.
3.  to confirm  
or

4.  to select "Stand. setting? No".

Then set the coding addresses as detailed in the table on page 2.

### Note

*The gas type only needs to be converted for operation with LPG. In the delivered condition, the control unit is set up for operation with natural gas.*

## Starting the boiler

1. Fit the front panel.
2. Start the boiler and check it is working correctly.

## Additional coding addresses

In conjunction with the new control unit, the following coding addresses can additionally be set:

Factory set code		Possible change	
16:50	With cyclical calibration, the boiler is started according to the heating curve. If the start point according to the heating curve is above 50 °C, the boiler is started at 50 °C.	16:30 to 16:127	The start point for calibration can be adjusted from 30 °C to 127 °C (limited by boiler-specific parameters)
17:42	With urgent calibration, the boiler is started according to the heating curve. If the start point according to the heating curve is above 42 °C, the boiler is started at 42 °C.	17:30 to 16:127	The start point for calibration can be adjusted from 30 °C to 127 °C (limited by boiler-specific parameters)
51:0	System with low loss header: The internal circulation pump always starts when there is a heat demand.	51:1	System with low loss header: The internal circulation pump only starts when there is a heat demand if the burner is running.
		51:2	System with heating water buffer cylinder: The internal circulation pump only starts when there is a heat demand if the burner is running.

## Additional fault codes

In conjunction with the new control unit, the following fault codes can additionally be displayed:

Fault code displayed	System characteristics	Cause of fault	Action
E1	Burner in a fault state	Ionisation current too high during calibration	Check gap between ionisation electrode and burner gauze assembly (see service instructions). In open flue operation, prevent high incidence of dust in the combustion air. Press reset button <b>R</b> .
E2	Burner in a fault state	Heating water flow rate too low during calibration. Flow switch caused shutdown.	Ensure adequate circulation volume. Check flow switch. Remove scaling and blockages. Press reset button <b>R</b> .
E3	Burner in a fault state	Heat transfer too low during calibration. Temperature limiter caused shutdown.	Ensure adequate heat transfer. Press reset button <b>R</b> .
E7	Burner in a fault state	Ionisation current too low during calibration	Check ionisation electrode (see service instructions): <ul style="list-style-type: none"> <li>■ Clearance to burner gauze assembly</li> <li>■ Electrode contamination</li> <li>■ Connecting lead and plug-in connections</li> </ul> Check flue system; remedy flue gas recirculation if required. Press reset button <b>R</b> .



## Additional fault codes (cont.)

Fault code displayed	System characteristics	Cause of fault	Action
EA	Burner in a fault state	Ionisation current outside permissible range during calibration (excessive deviation from previous level)	Check flue system; remedy flue gas recirculation if required. In open flue operation, prevent high incidence of dust in the combustion air. Press reset button <b>R</b> . Following several unsuccessful reset attempts, replace the boiler coding card and press reset button <b>R</b> .
Eb	Burner in a fault state	Repeated flame loss during calibration	Check gap between ionisation electrode and burner gauze assembly (see service instructions). Check the allocation of the gas type. Check flue system; remedy flue gas recirculation if required. Press reset button <b>R</b> .



For further information on troubleshooting, see the boiler service instructions.



Viessmann Werke GmbH & Co. KG  
D-35107 Allendorf  
Telephone: +49 6452 70-0  
Fax: +49 6452 70-2780  
www.viessmann.com

Viessmann Limited  
Hortonwood 30, Telford  
Shropshire, TF1 7YP, GB  
Telephone: +44 1952 675000  
Fax: +44 1952 675040  
E-mail: info-uk@viessmann.com

5782953 Subject to technical modifications.