









Volkswagen Cabriolet DIY Guide

Digifant II vs. Digifant I

Digifant I diagnostics begin on page 3.
 Digifant ECU pin-outs begin on page 5.

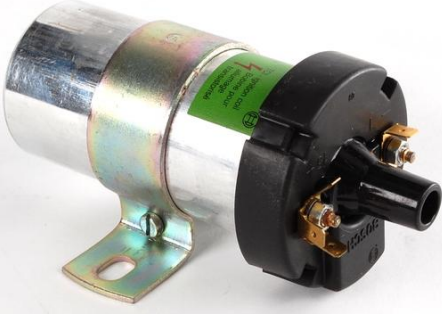
Digifant II	Component	Digifant I
<p style="text-align: center;">WVWCB015ZMK012345</p>  <p style="font-size: small;">www.AV-Autoverwertung.de</p>	VIN	<p style="text-align: center;">WVWCC015ZMK012346</p>  <p style="font-size: small;">www.TAV-Autoverwertung.de</p>
 <p>037906022CE / 037906022DE / 037906022EN KEN 5WP4016 / KEN 5WP4036 / Siemens 5WP4062 25-pin 1990-1993 49-state/International</p> <hr style="border-top: 1px dashed black;"/> <p>037906022CF / 037906022DD / 037906022EP KEN 5WP40?? / KEN 5WP40?? / KEN 5WP40?? 25-pin 1990 California</p>	ECU	 <p>037906023A / 037906023AB / 037906023Q KEN 5WP4038 / Siemens 5WP4115 38-pin 1991-1993 California</p>
 <p style="text-align: center;">054905377A</p>	Knock Sensor	 <p style="text-align: center;">054905377A</p>
 <p style="text-align: center;">211905115D</p>	Coil	 <p style="text-align: center;">6N0905104</p>



191905351B

Ignition Control Unit



867905352



Full-throttle & Idle Switches
037133093D

Throttle Switches



Throttle Position Sensor
(aka Throttle Valve Potentiometer)
044907385A



2-pin at each injector; 2-pin at end of fuel rail

Injector Harness Connectors

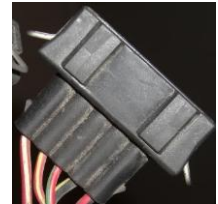

2-pin at each injector; 5-pin at end of fuel rail

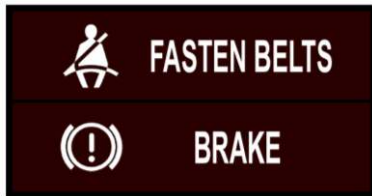

None

Diagnostics



OBD I

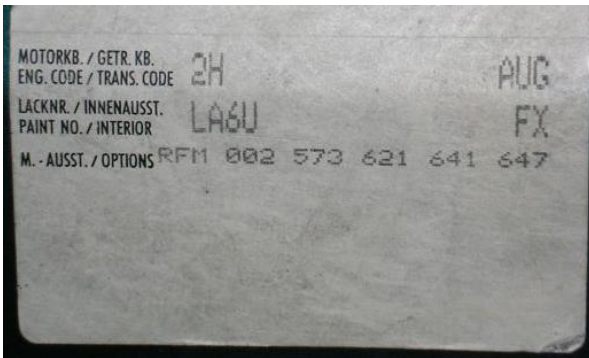

49-State
(none)

Build Sheet
M-Code

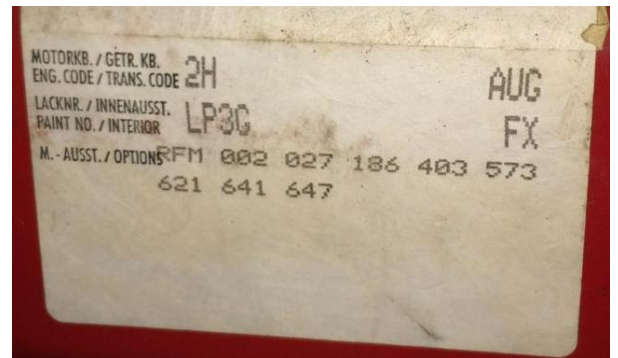

California Digifant I & II
(code 027)

Diagnostic Port Location

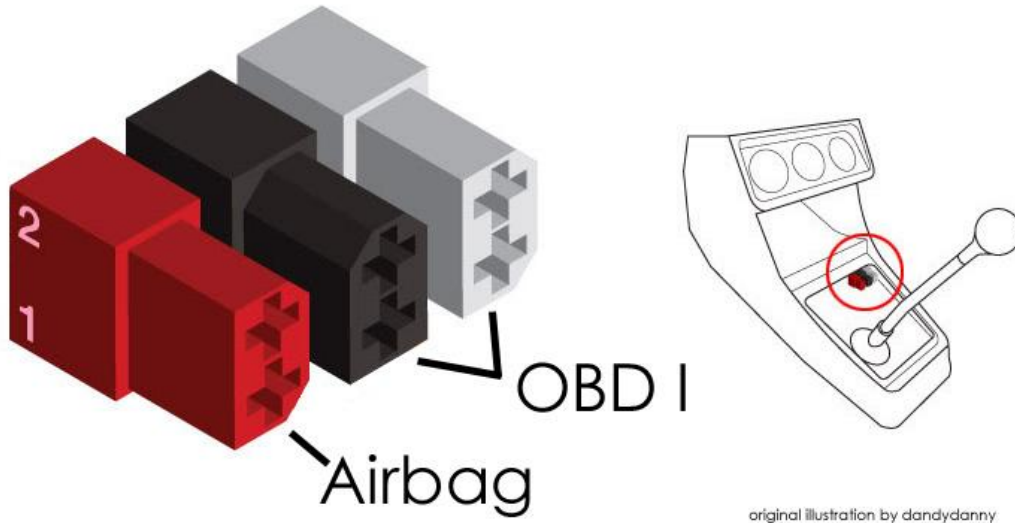

original illustration by dandydanny

Diagnostic Tools



Factory Jumper Tool
Part #357971415E



DIY or Store-bought Jumper Wire



OBD II to OBD I Adapter
VAS 5051/2 | Part #353721271

Pulling Codes ~ Jumper Method

1. Access diagnostic ports below shift boot.
2. Switch ignition to ON.
3. Connect jumper tool as shown at right: Black pin 1 (brown wire) first, followed by white pin 1 (yellow wire).
4. After 5 seconds the OBD CHECK light should begin to flash.
5. Remove jumper, but leave ignition on.
6. Record the number of flashes in sequence.
7. When code 4444 or 0000 appears, fault code sequence has ended. Note: 0000 is indicated by 2½-second flashes at 2½ intervals.
8. Switch ignition OFF to end code display.

Black Connector

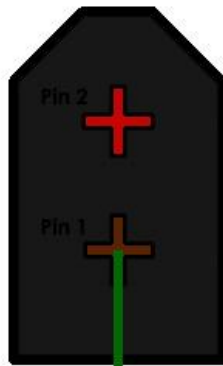

Red
(12V)

Brown
(ground)

White Connector

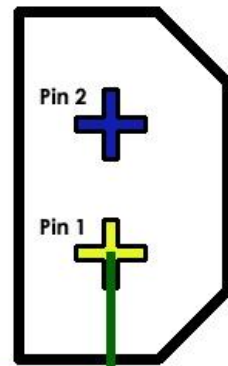

Blue
(K)

Yellow
(L)

jumper wire

Clearing Fault Code Memory

1. Ignition OFF.
2. Connect jumper tool as shown at right: Black pin 1 (brown wire) to white pin 1 (yellow wire).
3. Switch ignition ON.
4. After 5 seconds remove jumper.
5. OBD CHECK light should flash code 4444.
6. Switch ignition OFF.
7. If no new faults exist, memory will be cleared.

Black Connector

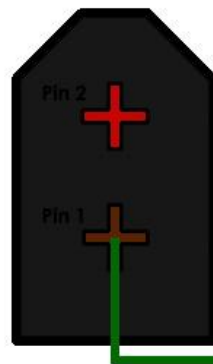

Red
(12V)

Brown
(ground)

White Connector

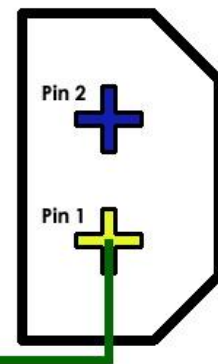

Blue
(K)

Yellow
(L)

jumper wire

OBD I Fault Codes

4444 = no faults recorded

2141 = knock sensor (defective knock sensor or wiring; control unit not recognizing knock signal)

2142 = knock sensor (defective knock sensor or wiring; control unit not recognizing knock signal)

2212 = throttle valve potentiometer (defective potentiometer or wiring)

2312 = coolant temperature sensor (defective coolant temperature sensor or wiring)

2322 = intake air temperature sensor (defective intake air temperature sensor or wiring)

2323 = airflow sensor potentiometer (defective airflow sensor potentiometer or wiring)

2341 = oxygen sensor control exceeded (air intake system leaks, CO adjustment incorrect, faulty sensor wiring)

2342 = oxygen sensor (faulty oxygen sensor or wiring)

4411 = fuel injector (check fuel injector wiring and/or injectors)

1111 = control unit (defective control unit)

0000 = end of fault code sequence

Resetting Digifant I ECU

If any of the following have occurred, the Digifant I control unit must be returned to its reference settings:

- Coolant temp sensor (blue) disconnected while is engine is running
- Digifant ECU replaced
- Airflow sensor replaced
- Throttle valve potentiometer replaced
- Throttle body replaced

In order to begin the reset process, the following are required:

- ✓ Engine at normal operating temperature (80°C); the radiator cooling fan should have cycled on at least once
- ✓ Exhaust system must be free of leaks
- ✓ Idle stabilization system in proper operating condition
- ✓ All electrical accessories must be switched off
- ✓ Engine nut running

Digifant I Control Unit Reset Procedure:

1. Disconnect the crankcase ventilation hose from the emission control valve on top of valve cover, then plug the hose.
2. Start the engine and let it idle.
3. Disconnect the blue coolant temp sensor.
4. After one minute, reconnect the coolant temp sensor.
5. Stop the engine.
6. Unplug and reconnect the crankcase ventilation hose.
7. Check and clear the OBD fault memory as described on page 2.

Volkswagen Cabriolet Digifant II Pinouts

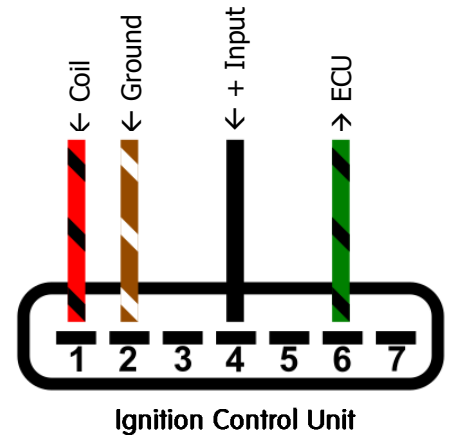
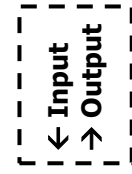
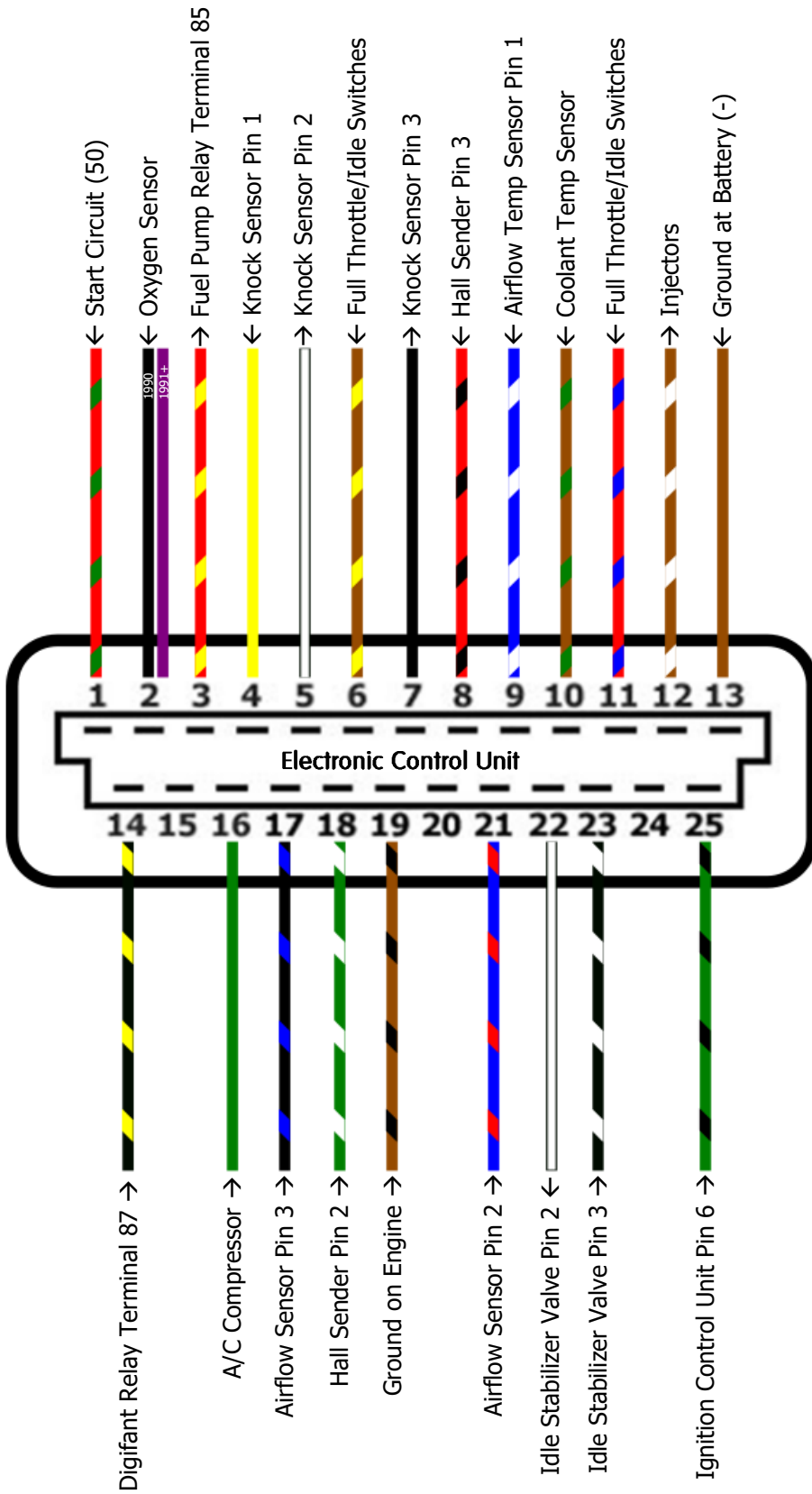

Volkswagen Cabriolet Digifant I ECU Pinout

