

LUMIN

Electric Grill



Owner's Guide

- LUMIN
- LUMIN COMPACT



REGISTER TODAY.

We are so glad that you have joined us on the journey to grilling greatness. Register your grill and gain access to fun and engaging WEBER information, including tips, tricks and how to get the most out of your grilling experience.

77445

101022
enUS - English

IMPORTANT SAFEGUARDS

DANGER, WARNING, and CAUTION statements are used throughout this Owner's Manual to emphasise critical and important information. Read and follow these statements to help ensure safety and prevent property damage. The statements are defined below.

- △ **DANGER:** Indicates a hazardous situation which, if not avoided, will result in death or serious injury.
- △ **WARNING:** Indicates a hazardous situation which, if not avoided, could result in death or serious injury.
- △ **CAUTION:** Indicates a hazardous situation which, if not avoided, could result in minor or moderate injury.

California Proposition 65

- △ **WARNING:** This product can expose you to chemicals including nickel, which is known to the state of California to cause cancer. For more information go to www.P65Warnings.ca.gov.

- △ Read all instructions.
- △ Household use only.

△ CAUTION

- △ To ensure continued protection against risk of electric shock, connect to properly grounded outlets only.
- △ Risk of electric shock, keep extension cord connection dry and off the ground.
- △ Hot surface.

Operation

When using electrical appliances, basic safety precautions should always be followed including the following:

△ DANGER

- △ To protect against electrical shock do not immerse cord, plugs, portable appliances (or other specific part or parts) in water or other liquid.

△ WARNING

- △ Use only outdoors in a well-ventilated area. Do not use in a garage, building, covered walkway, tent or any other enclosed area or beneath overhead combustible construction.
- △ Do not operate any appliance with a damaged cord or plug or after the appliance malfunctions or is dropped or damaged in any manner. Contact the Customer Service Representative in your area using the contact information on our web site. Log onto www.weber.com.
- △ Do not use the grill if there are damaged, defective, or modified parts.
- △ Do not operate the unit if the electrical socket is damaged.
- △ Do not modify the appliance. Modifications are unsafe and will void your warranty.
- △ Operate grill only on a level, heat-resistant surface.
- △ The use of accessories not recommended by WEBER may cause damage or injuries.
- △ Do not let cord hang over edge of table or counter or touch hot surfaces.
- △ Where applicable, always attach temperature controller to appliance and check that the control is OFF before plugging cord into wall outlet. To disconnect, turn the control to OFF, then remove plug from wall outlet.
- △ Do not use appliance for other than intended use.
- △ Fuel, such as charcoal briquettes, is not to be used with appliance.
- △ Use only on properly grounded outlet.

- △ Use extreme caution when removing tray or disposing of hot grease.
- △ Do not leave grill unattended when in use.
- △ Do not use as a heater.
- △ Do not use this barbecue unless all of the parts are in place and the barbecue was assembled according to the assembly instructions.
- △ Use this barbecue only as described in this manual. Misuse may cause fire, electric shock or injury.
- △ Do not build this model of grill in any built-in or slide-in construction.
- △ Your electric grill is not intended for installation in or on recreational vehicles, SUVs and/or boats.
- △ Do not use grill within 10 feet (3 m) of any body of water, such as a pool or pond.
- △ Do not use the grill within 24 inches (61 cm) of combustible materials. This includes the top, bottom, back and sides of the grill.
- △ Locate power cable away from traffic areas. Arrange the cable so that it will not be pulled or tripped over.

△ CAUTION

- △ Do not exceed the wattage of the electrical socket.
- △ Make sure no other high wattage appliances are plugged into the same circuit when using grill.
- △ Do not touch surfaces that may be hot. Use handles or knobs provided.
- △ Close supervision is necessary when any appliance is used by or near children.

Storage and/or Non-use

△ DANGER

- △ Make sure appliance is OFF and remove plug from outlet when not in use, before putting on or taking off parts, and before cleaning. Allow to cool before handling.

△ WARNING

- △ Always unplug by pulling the plug. Do not pull on the cable.

△ CAUTION

- △ Store Temperature Controller indoors when not in use - out of the reach of children.
- △ Allow the appliance to cool before moving, cleaning or storing it.
- △ Cover the grill only when it is cool.

Grounding Instructions

This appliance shall be grounded while in use to protect the operator from electric shock. The appliance is equipped with a 3-conductor cord and a 3-prong grounding-type plug to fit the proper grounding-type receptacle. Plug into a GFI-protected outdoor receptacle, where available.

Extension Cords

⚠ CAUTION: To minimise the risk of property damage and/or personal injury, do not use an extension power-supply cable unless it conforms to the specifications listed in this manual.

- If it is necessary to use an extension cord it must be connected to a grounded socket. Plug type: NEMA 5-15R to NEMA 5-15P; Gauge: 16 AWG; Rating: 125 volts at 13 amps. The maximum length for the extension cord is 20 feet (6 meters). Keep the extension cord as short as possible.
- Keep the connections dry.
- Observe all local laws and regulations when using this appliance.
- Use only 3-wire extension cords that have 3-prong grounding-type plugs and 3-pole connectors that accept the plug from the appliance.
- Only extension cords surface marked with the suffix letter "W" and identified by the marking "Suitable for use with outdoor appliances" shall be used outdoors.
- Use only extension cords having an electrical rating not less than the rating of the appliance.
- Do not use damaged extension cords. Examine extension cord before using and replace if damaged. Do not abuse extension cord and do not tug on any cord to disconnect. Keep cord away from heat and sharp edges.
- The cord should be arranged so that it will not drape over the countertop or tabletop where it can be pulled on by children or tripped over unintentionally.

Circuit Breaker

Your grill operates on 13 amps of electric current.

For the best experience and to prevent power loss:

- 15-20 amp circuit breaker on the outlet being used is recommended (normal breaker amperage).

NOTE: If the grill is used on a lower current outlet, circuit tripping could occur.

- Identify other electrical devices powered by the exterior circuit breaker that the grill will be plugged in to (i.e.: a patio lamp). If they require more than 2 amps of current, then unplug them before plugging in your grill.

HELLO!

We are so glad that you have joined us on the journey to grilling happiness. Please take some time to read through this Owner's Manual to ensure that you are up and grilling quickly and easily. We want to be with you for the life of your grill, so please take just a couple of minutes to register your grill. When you sign up for a WEBER account as part of your registration, we will deliver special grill-related content just for you to enjoy.

So, come along and join us online, on your smart device or however else you'd like to stay in touch.

Thank you for choosing WEBER.
We are happy you are here.

Table of Contents

2	Welcome to WEBER Important Safeguards
4	The WEBER Promise
5	Assembly Parts List
6	Operation Getting Started Meal-to-Meal Upkeep High-Heat Searing Setup Steaming Setup Smoke Infusion Setup Food Warming Setup Grill from Frozen Setup Cleaning the Steaming/Smoking Reservoir
10	Tips and Hints Grilling Do's and Don'ts
11	Product Care Deep Cleaning and Maintenance
12	Troubleshooting
13	Replacement Parts

**This appliance is rated for
120 V - 50/60Hz**

**Output Power (Watts):
1560 W**

**Use only WEBER
temperature controller plug.**

The WEBER Promise

At WEBER, we pride ourselves on two things: making grills that last and providing a lifetime of excellent customer service.

Thank you for purchasing a WEBER product. Weber-Stephen Products LLC, 1415 S. Roselle Road, Palatine, Illinois 60067 ("WEBER") prides itself on delivering a safe, durable, and reliable product.

This is WEBER's Voluntary Warranty provided to you at no extra charge. It contains the information you will need to have your WEBER product repaired in the unlikely event of a failure or defect.

Pursuant to applicable laws, the customer has several rights in case the product is defective. Those rights include supplementary performance or replacement, abatement of the purchasing price, and compensation. In the European Union, for example, this would be a two-year statutory warranty starting on the date of the handover of the product. These and other statutory rights remain unaffected by this warranty provision. In fact, this warranty grants additional rights to the Owner that are independent from statutory warranty provisions.

WEBER'S VOLUNTARY WARRANTY

WEBER warrants, to the purchaser of the WEBER product (or in the case of a gift or promotional situation, the person for whom it was purchased as a gift or promotional item), that the WEBER product is free from defects in material and workmanship for the period(s) of time specified below when assembled and operated in accordance with the accompanying Owner's Manual. (Note: If you lose or misplace your WEBER Owner's Manual, a replacement is available online at www.weber.com, or such country-specific website to which Owner may be redirected.) Under normal, private single family home or apartment use and maintenance, WEBER agrees within the framework of this warranty to repair or replace defective parts within the applicable time periods, limitations, and exclusions listed below. TO THE EXTENT ALLOWABLE BY APPLICABLE LAW, THIS WARRANTY IS EXTENDED ONLY TO THE ORIGINAL PURCHASER AND IS NOT TRANSFERABLE TO SUBSEQUENT OWNERS, EXCEPT IN THE CASE OF GIFTS AND PROMOTIONAL ITEMS AS NOTED ABOVE.

OWNER'S RESPONSIBILITIES UNDER THIS WARRANTY

To ensure trouble-free warranty coverage, it is important (but it is not required) that you register your WEBER product online at www.weber.com, or such country-specific website to which Owner may be redirected. Please also retain your original sales receipt and/or invoice. Registering your WEBER product confirms your warranty coverage and provides a direct link between you and WEBER in case we need to contact you.

The above warranty only applies if the Owner takes reasonable care of the WEBER product by following all assembly instructions, usage instructions, and preventative maintenance as outlined in the accompanying Owner's Manual, unless the Owner can prove that the defect or failure is independent of non-compliance with the above mentioned obligations. If you live in a coastal area, or have your product located near a pool, maintenance includes regular washing and rinsing of the exterior surfaces as outlined in the accompanying Owner's Manual.

WARRANTY HANDLING / EXCLUSION OF WARRANTY

If you believe that you have a part which is covered by this Warranty, please contact WEBER Customer Service using the contact information on our website (www.weber.com, or such country-specific website to which Owner may be redirected). WEBER will, upon investigation, repair or replace (at its option) a defective part that is covered by this Warranty. In the event that repair or replacement are not possible, WEBER may choose (at its option) to replace the grill in question with a new grill of equal or greater value. WEBER may ask you to return parts for inspection, shipping charges to be pre-paid.

This WARRANTY lapses if there are damages, deteriorations, discolorations, and/or rust for which WEBER is not responsible caused by:

- Abuse, misuse, alteration, modification, misapplication, vandalism, neglect, improper assembly or installation, and failure to properly perform normal and routine maintenance;
- Exposure to salt air and/or chlorine sources such as swimming pools and hot tubs/spas;
- Severe weather conditions such as hail, hurricanes, earthquakes, tsunamis or surges, tornadoes or severe storms.

Any parts that are used and/or installed on your WEBER product that are not genuine WEBER parts are not covered by this Warranty. Any damages that result from the use and/or installation of parts on your WEBER product that are not genuine WEBER parts are not covered by this Warranty. Any conversion of a gas grill not authorized by WEBER and performed by a WEBER authorized service technician will void this Warranty.

PRODUCT WARRANTY PERIODS

Cookbox:

5 years, no rust through/burn through
(2 years paint excluding fading or discoloration)

Lid assembly:

5 years, no rust through/burn through
(2 years paint excluding fading or discoloration)

Porcelain-enamelled cast iron cooking grates:

5 years, no rust through/burn through

Plastic components:

5 years, excluding fading or discoloration

All remaining parts:

2 years

DISCLAIMERS

APART FROM THE WARRANTY AND DISCLAIMERS AS DESCRIBED IN THIS WARRANTY STATEMENT, THERE ARE EXPLICITLY NO FURTHER WARRANTY OR VOLUNTARY DECLARATIONS OF LIABILITY GIVEN HERE WHICH GO BEYOND THE STATUTORY LIABILITY APPLYING TO WEBER. THE PRESENT WARRANTY STATEMENT ALSO DOES NOT LIMIT OR EXCLUDE SITUATIONS OR CLAIMS WHERE WEBER HAS MANDATORY LIABILITY AS PRESCRIBED BY STATUTE.

NO WARRANTIES SHALL APPLY AFTER THE APPLICABLE PERIODS OF THIS WARRANTY. NO OTHER WARRANTIES GIVEN BY ANY PERSON, INCLUDING A DEALER OR RETAILER, WITH RESPECT TO ANY PRODUCT (SUCH AS ANY "EXTENDED WARRANTIES"), SHALL BIND WEBER. THE EXCLUSIVE REMEDY OF THIS WARRANTY IS REPAIR OR REPLACEMENT OF THE PART OR PRODUCT.

IN NO EVENT UNDER THIS VOLUNTARY WARRANTY SHALL RECOVERY OF ANY KIND BE GREATER THAN THE AMOUNT OF THE PURCHASE PRICE OF THE WEBER PRODUCT SOLD.

YOU ASSUME THE RISK AND LIABILITY FOR LOSS, DAMAGE, OR INJURY TO YOU AND YOUR PROPERTY AND/OR TO OTHERS AND THEIR PROPERTY ARISING OUT OF THE MISUSE OR ABUSE OF THE PRODUCT OR FAILURE TO FOLLOW INSTRUCTIONS PROVIDED BY WEBER IN THE ACCOMPANYING OWNER'S MANUAL.

PARTS AND ACCESSORIES REPLACED UNDER THIS WARRANTY ARE WARRANTED ONLY FOR THE BALANCE OF THE ABOVE MENTIONED ORIGINAL WARRANTY PERIOD(S).

THIS WARRANTY APPLIES TO PRIVATE SINGLE FAMILY HOME OR APARTMENT USE ONLY AND DOES NOT APPLY TO WEBER GRILLS USED IN COMMERCIAL, COMMUNAL OR MULTI-UNIT SETTINGS SUCH AS RESTAURANTS, HOTELS, RESORTS, OR RENTAL PROPERTIES.

WEBER MAY FROM TIME TO TIME CHANGE THE DESIGN OF ITS PRODUCTS. NOTHING CONTAINED IN THIS WARRANTY SHALL BE CONSTRUED AS OBLIGATING WEBER TO INCORPORATE SUCH DESIGN CHANGES INTO PREVIOUSLY MANUFACTURED PRODUCTS, NOR SHALL SUCH CHANGES BE CONSTRUED AS AN ADMISSION THAT PREVIOUS DESIGNS WERE DEFECTIVE.

Weber-Stephen PRODUCTS LLC

Customer Service Center

1415 S. Roselle Road
Palatine, IL 60067
U.S.A.

For replacement parts, call:

1-800-446-1071

Parts List

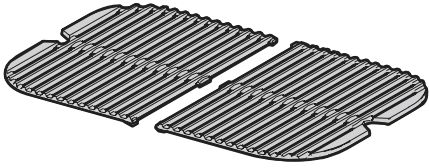

Porcelain-Enamelled Cast Iron Cooking Grates

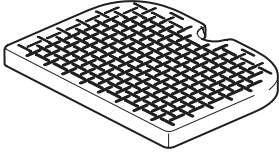

Reversible Steam Pan

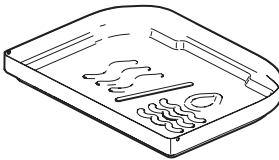

Steaming/Smoking Reservoir

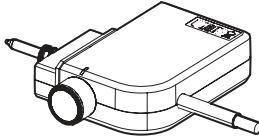

Temperature Controller

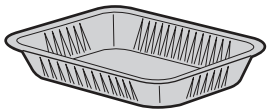

Disposable Drip Tray

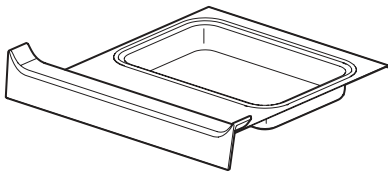

Slide-Out Catch Pan

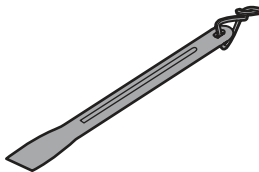

Plastic Scraper

Assembly

These instructions will give you the minimum requirements for assembling your WEBER electric grill. Improper assembly can be dangerous.

⚠ WARNING: Do not modify the appliance. Modifications are unsafe and will void your warranty.

⚠ Remove all packaging materials and protective film before operating your grill.

- Any parts sealed by the manufacturer must not be opened or altered by the user.
- Do not cover any parts of the grill with aluminum foil. It may negatively impact the performance of your grill.

1 Install Grates

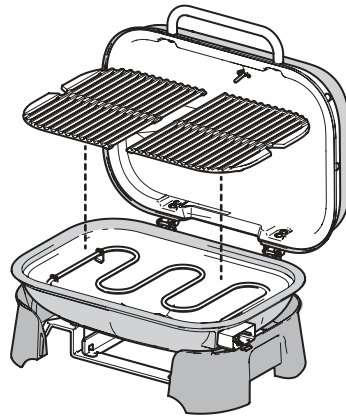

2 Install Grease Tray

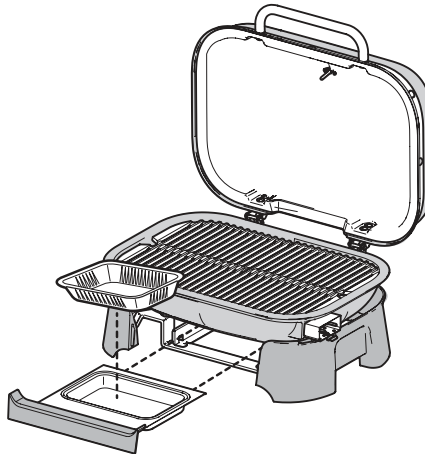

3 Attach Temperature Controller

Refer to "Getting Started" for proper attachment of the temperature controller.

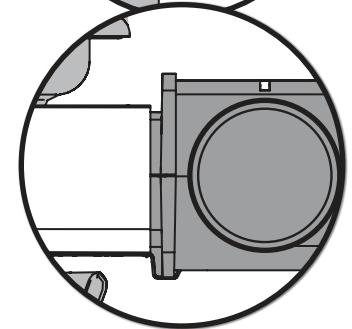
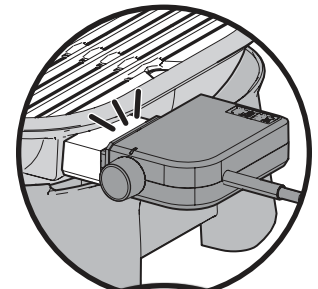
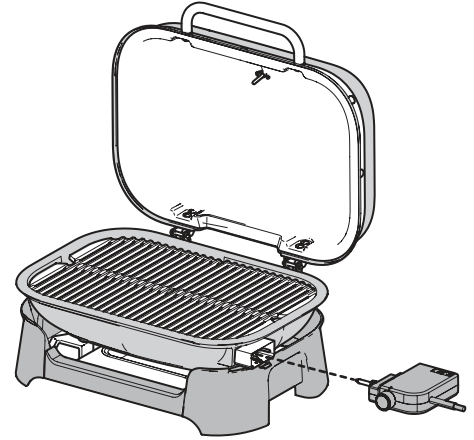

The grills that are illustrated in this Owner's Manual may vary slightly from the model purchased.

Getting Started

Attach Temperature Controller

- 1) Plug the temperature controller into the grill by pushing it straight onto the mounting bracket **(A)** until the controller clicks into place and sits flat to the mounting bracket. Ensure that the heating element pins are aligned with temperature controller for proper attachment **(B)**.
- 2) Route the power cable behind the grill, away from heated surfaces. Wrap excess cord with the cord wrap.
- 3) Plug the power cable into a grounded socket.

Preheat the Grill

Preheating the grill is critical to successfully using all of the grill's features, including barbecuing, steaming, smoking, and keeping food warm. Preheating helps to prevent food from sticking to the cooking grate and gets the cooking grate hot enough to sear properly. It also burns off residue of a previously-cooked meal.

- 1) Preheat the grill with the control knob in the high position **(C)**. The LED light will turn on indicating the grill is on.
- 2) When the temperature registers 500°F (260°C) the grill is preheated. This will take approximately 15 to 20 minutes depending on ambient conditions.
- 3) To grill at a lower temperature: Preheat as outlined above. Turn the knob counter-clockwise to the desired setting. Start barbecuing.

Ambient Conditions

Grilling in a colder climate or at a higher altitude will extend your cooking time. Sustained wind will lower the grill's internal temperature. Place grill so wind blows against the front of the grill.

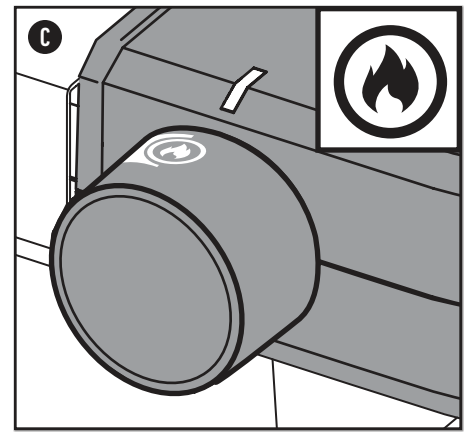
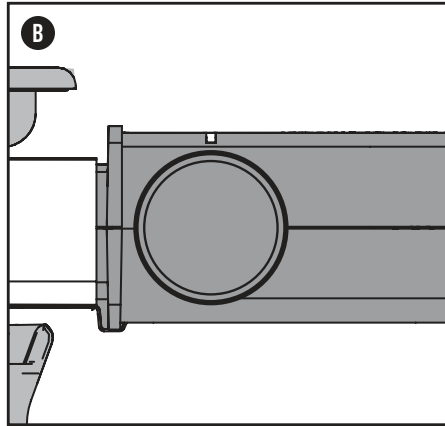
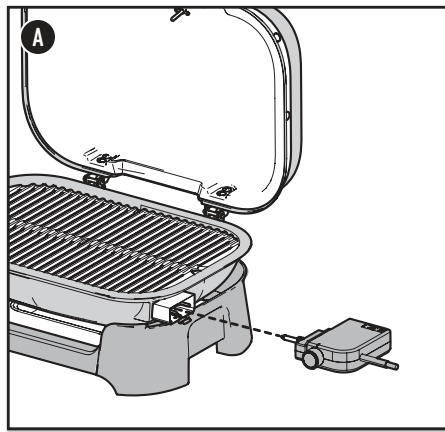

Perform an Initial Burn-Off

Heat the grill on the highest setting, with the lid closed, for at least twenty minutes prior to grilling for the very first time.

⚠ WARNING

- ⚠ Use heat-resistant grill mitts or gloves when operating grill.
- ⚠ Should a grease fire occur, close the lid, unplug the grill from the socket and leave the lid closed until the fire is extinguished. Do not use liquid to extinguish flames.
- ⚠ Do not throw open the lid or push open the lid beyond normal operation.
- ⚠ Temperature controller is not a handle. Do not lift the grill from the temperature controller.
- ⚠ Do not set or store items on the temperature controller.

Meal-to-Meal Upkeep

Keep it Clean

Accumulated dirt and grease may reduce grill performance. Factors such as altitude, wind and outside temperature can affect cooking times.

Check for Grease Before Every Cook

Your grill was built with a grease management system that funnels grease away from food and into a disposable container. As you cook, grease is channeled down to the slide-out catch pan and into a disposable drip pan that lines the catch pan. This system should be cleaned each and every time you grill in order to prevent fires.

- 1) Confirm that the grill is off and cool.
- 2) Remove the slide-out catch pan by pulling it forward (A).
- 3) Check for grease in the disposable drip pan that lines the slide-out catch pan. Discard disposable drip pan when necessary and replace with a new one.
- 4) Reinstall all components.

Clean the Cooking Grate After Preheating

After preheating, any bits of food or debris left over from previous use will be easier to remove. Clean cooking grates will also prevent your next meal from sticking.

- 1) Brush the cooking grates with a stainless steel bristle grill brush (sold separately) immediately after preheating (B).

Cleaning and Storing the Temperature Controller

When cooking is complete and the grill is off, allow the temperature controller to cool before wiping it clean.

- 1) Unplug and remove temperature controller by pulling it side-to-side slightly until it releases from the mounting bracket (C).
- 2) Wipe down temperature controller with a microfiber cloth dampened with water and allow to completely dry. Do not use cleaners or brushes as they will scratch the surface. Never use glass cleaners on plastic. It will damage the surface. Do not immerse in water.
- 3) Store the temperature controller indoors, out of the reach of children.

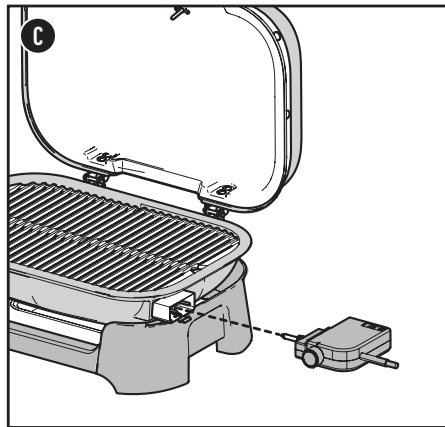
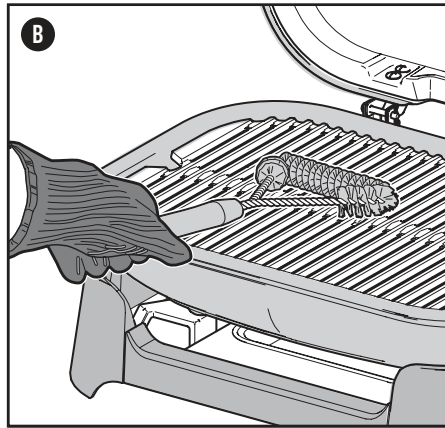
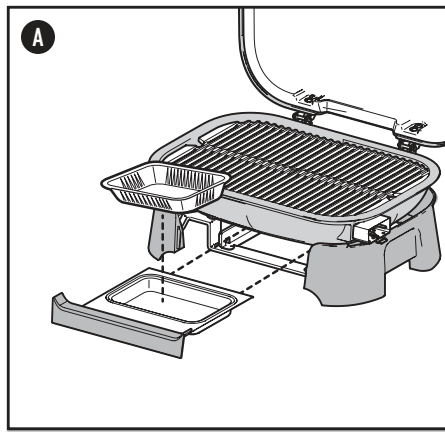

⚠ WARNING

- ⚠ The grill should be thoroughly cleaned on a regular basis.
- ⚠ Do not line the slide-out catch pan or any part of the grill with aluminum foil.
- ⚠ Use caution when removing catch pan and disposing of hot grease.
- ⚠ Check the slide-out catch pan for grease build-up before each use. Remove excess grease to avoid a grease fire.
- ⚠ Grill brushes should be checked for loose bristles and excessive wear on a regular basis. Replace brush if any loose bristles are found on cooking grates or brush. WEBER recommends purchasing a new stainless steel bristle grill brush at the beginning of every spring.

⚠ CAUTION

- ⚠ Temperature controller should be removed from grill and stored indoors when grill is not in use - out of the reach of children.

5-in-1 Versatility

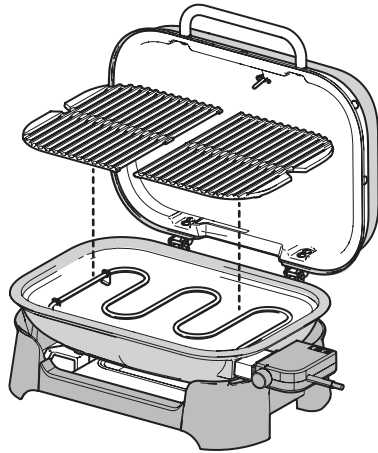

High-Heat Searing Setup



Using only the porcelain-enameled cooking grates, turn the control knob to the high setting and preheat the grill with the lid closed to at least 500°F (260°C). Higher preheating

temperatures will provide the best searing results. Brush the cooking grates clean with a stainless steel bristle grill brush.

Place food on cooking grates and close the lid. Turn your food only once during the grilling time. Lift the lid only to turn the food or check for the doneness at the end of the recommended grilling time.

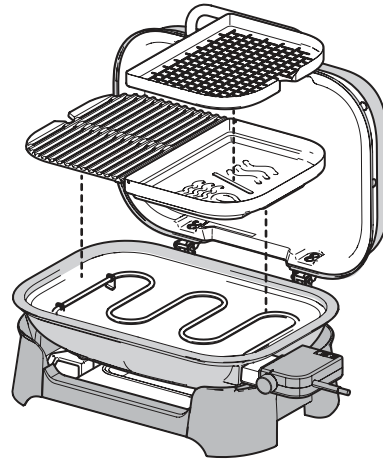

Steaming Setup



Powerful and ready to steam in 10 minutes.

With the grill OFF and cool, remove one cooking grate. Place reservoir in the cookbox and fill with water up to the shelf line.

Place the reversible steam pan onto the water reservoir making sure the walls of the steam pan extend upwards to act as a basket for veggies or other small foods.

Close the lid. Turn the control knob to the high setting and preheat the grill for 10-15 minutes. Brush the cooking grates clean with a stainless steel bristle grill brush.

Reduce heat by turning control knob to Steam setting.

Place delicate foods into the steam pan.

Close the lid and cook your food to the desired doneness. For best results, keep the lid closed as much as possible while steaming.

Note: If cooking on the grill side and steam side at once, set the grill to the temperature that is best for your grilled food.

Note: For the best performance, use the steam reservoir on the right-hand side of the grill.

Note: Lid thermometer will not show accurate temperatures with the steam system in place.

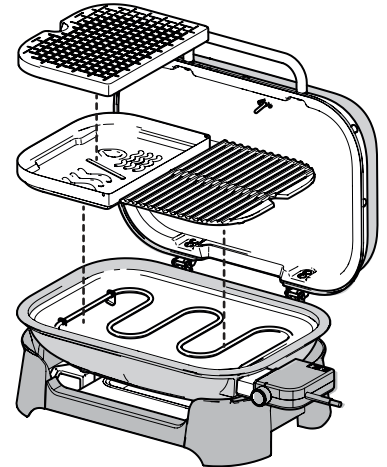

Smoke Infusion Setup



With the grill OFF and cool, remove one cooking grate. Place the dry reservoir in the cookbox and fill with a handful of wood chips. Do not add water. Place the reversible steam pan

onto the reservoir making sure the walls of the steam pan extend downwards allowing the top surface of the pan to be flat.

Turn the control knob to the high setting and preheat the grill for 5-10 minutes until smoke noticeably begins to form. Brush the cooking grates clean with a stainless steel bristle grill brush.

Reduce heat by turning control knob to Smoke setting.

Food can be placed either on the cooking grate, or directly on the surface of the pan to infuse the food with smoke flavor. Do not cover all of the holes of the pan.

Always grill with the lid closed to allow the smoke to fully penetrate the food.

When you're finished smoking, turn control knob off and close the grill lid until the wood chips have extinguished.

Note: For the best performance of smoke infusion, use the dry reservoir with wood chips on the left-hand side of the grill. The wood chips may be pre-soaked according to the manufacturer's instructions.

Firespice Smoking Chart

Enhance the flavor of your food with authentic wood fired taste. Experimenting with adding flavored wood chips to the recipe makes smoking and grilling even more delicious. Firespice wood chips sold separately

	APPLE FIRESPICE	CHERRY FIRESPICE	PECAN FIRESPICE	HICKORY FIRESPICE	MESQUITE FIRESPICE
	✓	✓	✓		
	✓	✓	✓	✓	
	✓	✓	✓	✓	✓
			✓		✓
			✓	✓	✓
	✓	✓			

⚠ DANGER

⚠ Do not use any flammable fluid or combustible products in the smoker to ignite the wood chips. This will cause serious bodily injury.

⚠ WARNING

⚠ Never use wood pellets or smoking dust in the smoker.

⚠ Never use wood that has been treated or exposed to chemicals.

⚠ Always avoid soft, resinous woods like pine, cedar, and aspen.

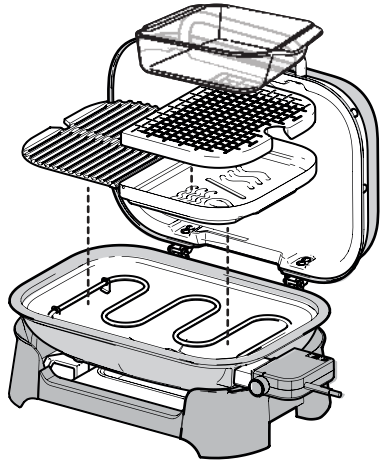

Food Warming Setup



With the grill OFF and cool, remove one cooking grate. Place reservoir in the cookbox and fill with water up to the shelf line. Place steam pan onto the water reservoir making sure the walls of the steam pan extend downwards allowing the top surface of the pan to be flat.

Turn the control knob to the Low setting.

Place an oven-safe dish, maximum size 9.6" x 7.0" x 1.5" (24 cm x 17.75 cm x 3.8 cm) (sold separately), on the steam pan. The water in the reservoir will keep the food warm and maintain moisture without allowing it to burn.

Monitor the water level in the reservoir every 30-60 minutes and add water if necessary.

To grill while keeping food warm, adjust temperature controller to high while food cooks, then turn the control knob to Food Warming while serving.

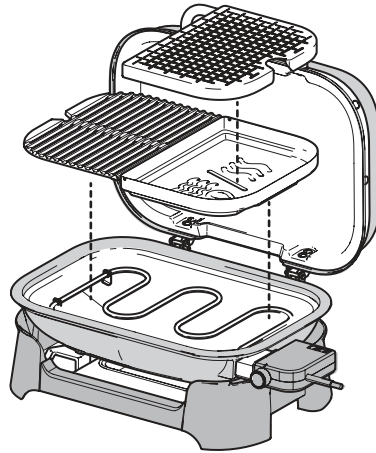

Grill from Frozen Setup



With the grill OFF and cool, remove one cooking grate. Place reservoir in the cookbox and fill with 1 cup (250 ml) of water. Place steam pan onto the water reservoir with either side up, and place the frozen food on the steam pan in the COLD grill.

Turn the control knob to the high setting and preheat the grill for 15 minutes. Brush the cooking grates clean with a stainless steel bristle grill brush.

Check if the food has defrosted after 15 minutes, or add more time if necessary.

After the food has defrosted, move the food to the cooking grate to grill to desired doneness.

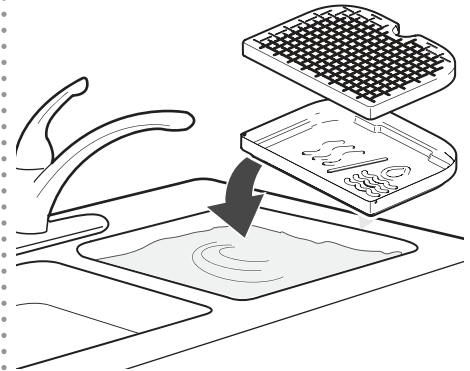

Cleaning the Steaming/Smoking Reservoir

After each use allow components to cool, then empty the reservoir of water and ash to allow proper air flow. Wash the reservoir and steam pan with warm soapy water. Then, thoroughly rinse

Note: Smoking will leave a "smoke" residue on the surface of the steamer/smoker. This residue cannot be removed and will not affect the function of the steamer/smoker. To a lesser degree, a "smoke" residue will accumulate on the inside of your grill. This residue need not be removed and will not adversely affect the function of your grill. Do not submerge grill.

Note: Remove steaming/smoking reservoir from the grill if not in use.

Temperature Controller Settings:

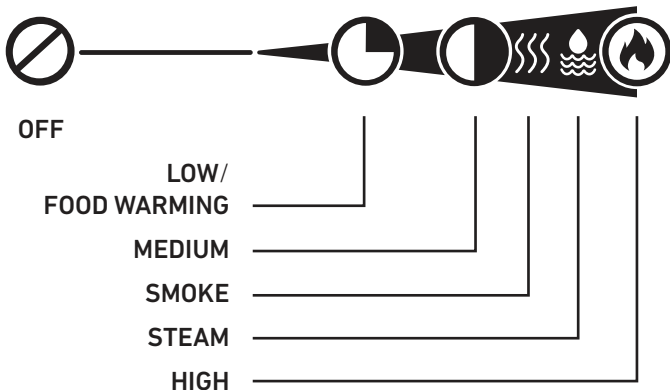

Water Reservoir Capacity:

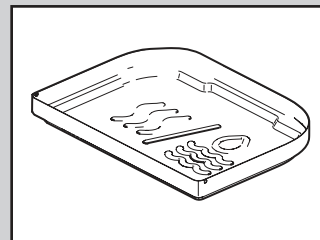

LUMIN

3 cups (750 ml) to shelf line / 11 cups (2.8 L) maximum

LUMIN COMPACT

2 cups (500 ml) to shelf line / 8 cups (1.9 L) maximum

⚠ WARNING

⚠ Use heat-resistant grill mitts or gloves when operating grill.

⚠ Do not remove hot components from the grill while in use.

Grilling Do's and Don'ts

Preheat grill each and every time.

If the cooking grates are not hot enough, the food will stick and you will likely never have a chance of searing your food properly or developing those handsome sear marks. Even if a recipe calls for medium or low heat, always preheat the grill on highest setting first.

Don't grill on dirty grates.

Placing food onto the cooking grates before they have been cleaned is never a good idea. Left over residue on the grates acts like glue, binding it to the grates and to your food. To avoid tasting last night's dinner on today's lunch, make sure that you are barbecuing on a clean cooking grate. Once the grates are preheated, use a stainless steel bristle grill brush to make a clean, smooth surface.

Be present in the process.

Before starting your grill, make sure that everything you need is within arm's reach. Don't forget your essential barbecuing tools, such as oiled and seasoned food, glazes or sauces and clean cooking platters for the cooked food. Having to run back to your kitchen not only means missing out on the fun, but it could also result in burning your food. French chefs call this 'mise en place' (meaning, 'put in place'). We call it 'being present'.

Create a little elbow room.

Packing too much food onto the cooking grates restricts your flexibility. Leave at least one-quarter of the cooking grates clear with plenty of space between each food item in order to get your tongs in there and easily move the food around. Sometimes barbecuing involves split-second decisions and the need to move food from one area of the grill to another. So give yourself enough room to grill.

Try not to peek.

The lid on your grill is for more than just keeping the rain out. Most importantly, it's for preventing too much air from getting in and too much heat and smoke from getting out. When the lid is closed, the cooking grates are hotter, the cooking times are faster and the smoky tastes are stronger.

Only flip once.

What's better than a juicy steak with a deep sear and plenty of beautifully-caramelised bits? The key to accomplishing these results is to keep your food in place. Sometimes we have the tendency to flip our food before it reaches the desired level of color and flavour. In nearly all cases, you should turn food just once. If you are moving it more than that, you are probably also opening the lid too often which causes its own set of problems. So step back and trust the grill.

Deep Cleaning and Maintenance

CLEANING THE INSIDE OF THE GRILL

Over time, the performance of your grill can diminish if it has not been maintained properly.

Low temperatures, uneven heat and food sticking to cooking grates are all signs that cleaning and maintenance are overdue. When your grill is off and cool, start by cleaning the inside from the top down.

A thorough cleaning is recommended after every five cooks. Consistent use may require more frequent cleanings.

Cleaning the Lid

From time to time you may notice 'paint-like' flakes on the inside of the lid. During use, grease and smoke vapours slowly change into carbon and deposit on the inside of your grill's lid. These deposits will eventually peel and look very similar to paint. These deposits are non-toxic, but the flakes could fall onto your food if you do not clean the lid regularly.

- 1) Use a plastic scraper to remove carbonised grease from inside the lid (A).

Cleaning the Cooking Grates

If you have been cleaning your cooking grates as recommended, the debris on your grates should be minimal.

- 1) With grates installed, brush the debris off your cooking grate with a stainless steel bristle grill brush (sold separately) (B).
- 2) Take the grates out and set aside.

Note: Cooking grates are dishwasher safe.

Cleaning the Bowl Liner and Cookbox

Look inside the cookbox for any grease accumulation or leftover food particles. Excessive accumulation can cause a fire.

It is recommended to use gloves when removing the heating element.

Do not use metal brushes to clean heating elements.

- 1) Remove the temperature controller.
- 2) Remove the heating element by removing the two screws on the mounting bracket until the heating element releases (C).
- 3) Slide the heating element towards the left side of the grill. Taking care not to bend the heating element, tilt it upwards and remove it.
- 4) Use a plastic scraper to scrape debris off of the sides and bottom of the bowl liner into the opening in the bottom of the cookbox (D). This opening funnels debris into the slide-out catch pan.
- 5) Remove and clean the slide-out catch pan. Refer to 'Meal-to-Meal Upkeep' (E).

The bottom liner of the grill can be removed and washed with warm soapy water. Take care not to bend the bowl liner.

After cleaning, reinstall the bowl liner. Do not operate the grill without the bowl liner.

To reinstall the heating elements, insert the heating elements into the corresponding holes inside the front of the grill. Reattach by turning screws clockwise. Do not over-tighten.

Clean heating elements by allowing food to burn off.

CLEANING THE OUTSIDE OF THE GRILL

The outside of your grill may include aluminum, stainless steel and plastic surfaces.

WEBER recommends the following methods based on the surface type:

Cleaning Stainless Steel Surfaces

Clean stainless steel using a grease-cutting soap. Use a microfibre cloth to clean in the direction of the grain of the stainless steel. Rinse with clear water and dry thoroughly. Do not use paper towels. Do not use bleach or chlorinated cleaning products on stainless steel.

Note: Do not risk scratching your stainless steel with abrasive pastes. Pastes do not clean or polish. They will change the color of the metal by removing the top chromium oxide film coating.

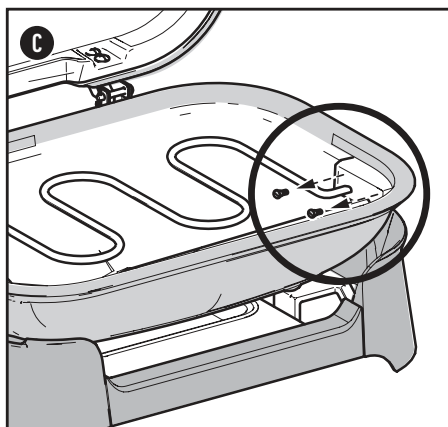
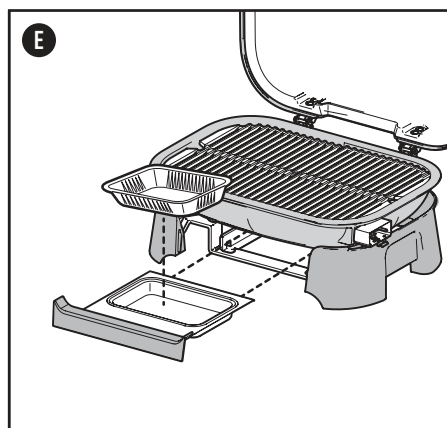
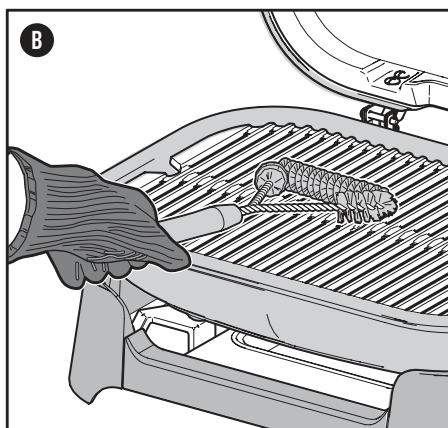
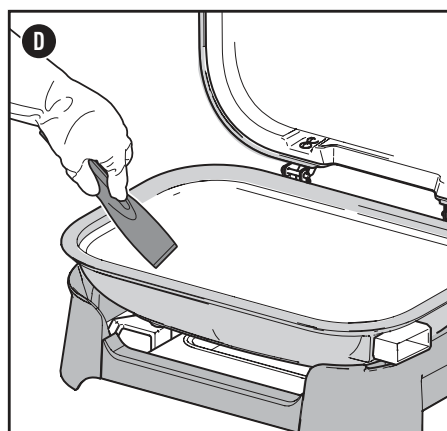
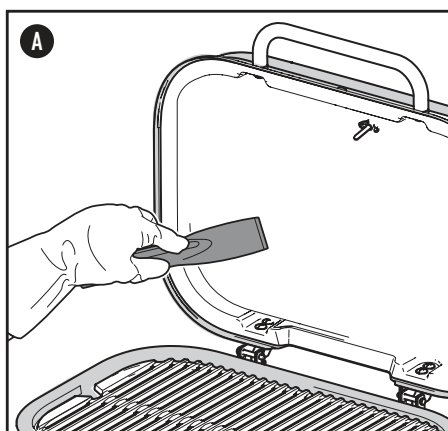

Cleaning Painted Surfaces and Plastic Components

Clean painted and plastic components with grease-cutting soap. Rinse with clear water and dry thoroughly.

Cleaning the Outside of Grills that are in Unique Environments

If your grill is subject to a particularly harsh environment, you will want to clean the outside more often. Acid rain, pool chemicals and salt water can cause surface rusting to appear. Wipe down the outside of your grill with warm soapy water. Follow up with a rinse and thorough drying. Additionally, for stainless steel parts only, you may want to apply a stainless steel polish cleaner weekly to prevent surface rust.

⚠ WARNING

- ⚠ Turn your grill off and wait for it to cool before thoroughly cleaning it.
- ⚠ Do not spray liquid on heating element or controller.
- ⚠ Do not immerse in water when cleaning.

⚠ CAUTION

- ⚠ Disconnect the appliance from the supply circuit and remove the temperature controller before performing cleaning and maintenance.
- ⚠ Do not use any of the following to clean your grill: abrasive stainless steel polishes or paints, cleaners that contain acid, mineral spirits or xylene, oven cleaner, abrasive cleaners (kitchen cleaners) or abrasive cleaning pads.
- ⚠ Do not use metal brushes to clean heating elements. Allow food to burn off during preheating.

⚠ WARNING

⚠ Do not attempt to make any repair to electric components or structural components without contacting Weber-Stephen Products LLC, Customer Services Department.

ELECTRIC GRILL DOES NOT TURN ON

SYMPTOM

- Heating element does not heat when following the instructions in the 'Operation' section of this Owner's Manual.

CAUSE

SOLUTION

The temperature controller may not be properly inserted into the housing.

Remove and reinstall temperature controller. Always plug the temperature controller into the grill before plugging power cable into the socket.

There is a problem with the power flowing from the socket. The circuit breaker may have tripped to cause a loss of power during use.

Identify other electrical devices that also lost power. Unplug these devices while using your grill. Check if different electrical outlets are available. Refer to "Important Safegaurds" if extension cords are needed. If your circuit breaker continues to trip during use, consult a qualified electrician.

The current limiting circuit that is built-in to the temperature controller may have interrupted the power to the grill.

If the temperature status indicator light is not on, unplug the power cable from the socket in order to 'reset' the current limiting circuit. Wait 30 seconds, then plug the power cable back into the socket.

**CALL
CUSTOMER
SERVICE**

If you are still experiencing any problems, contact the Customer Service Representative in your area using the contact information that can be found on weber.com.

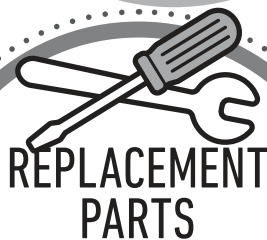

**REPLACEMENT
PARTS**

To obtain replacement parts, contact the local retailer in your area or log onto weber.com.

LUMIN - MEDIUM - US 070122

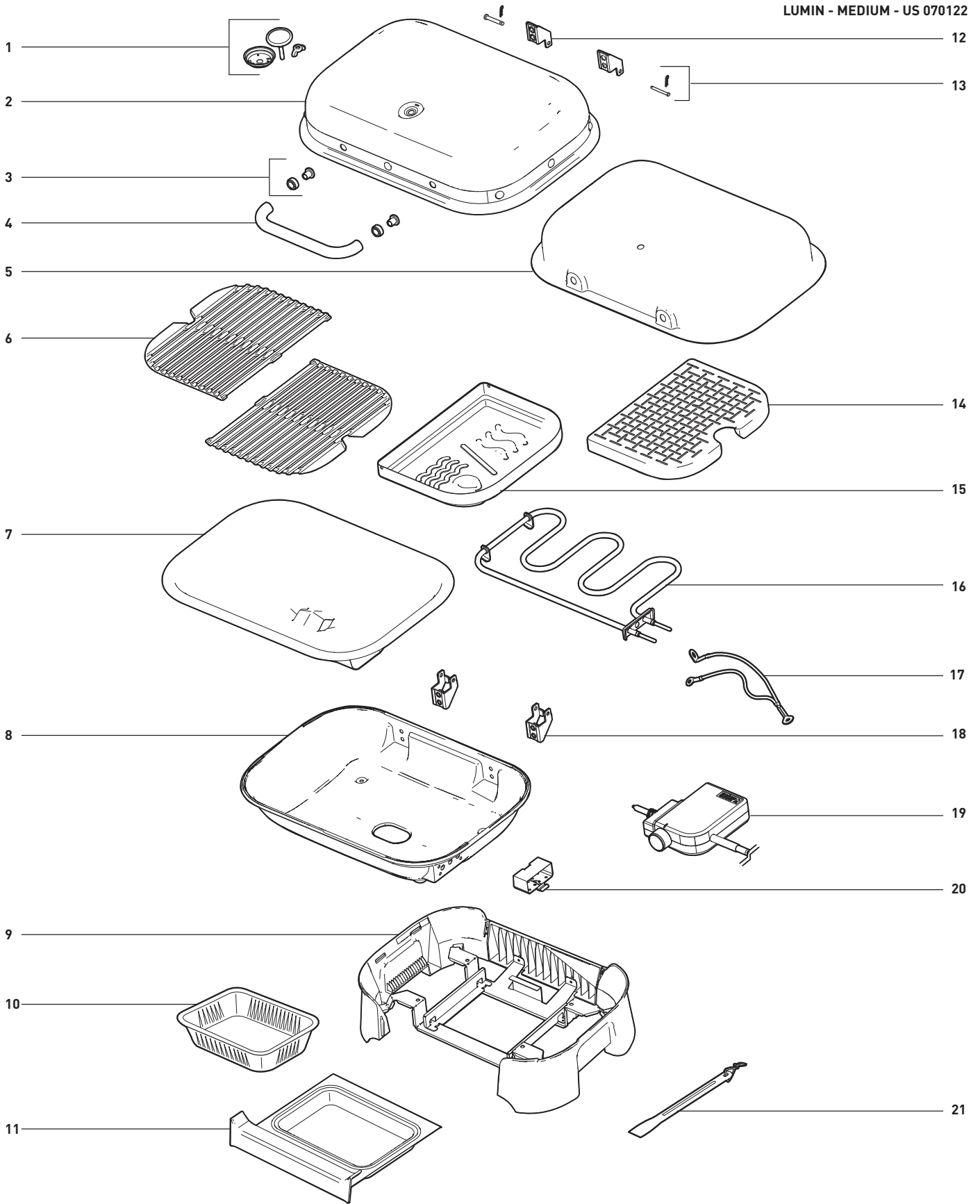

LUMIN COMPACT

LUMIN - COMPACT - US 070122

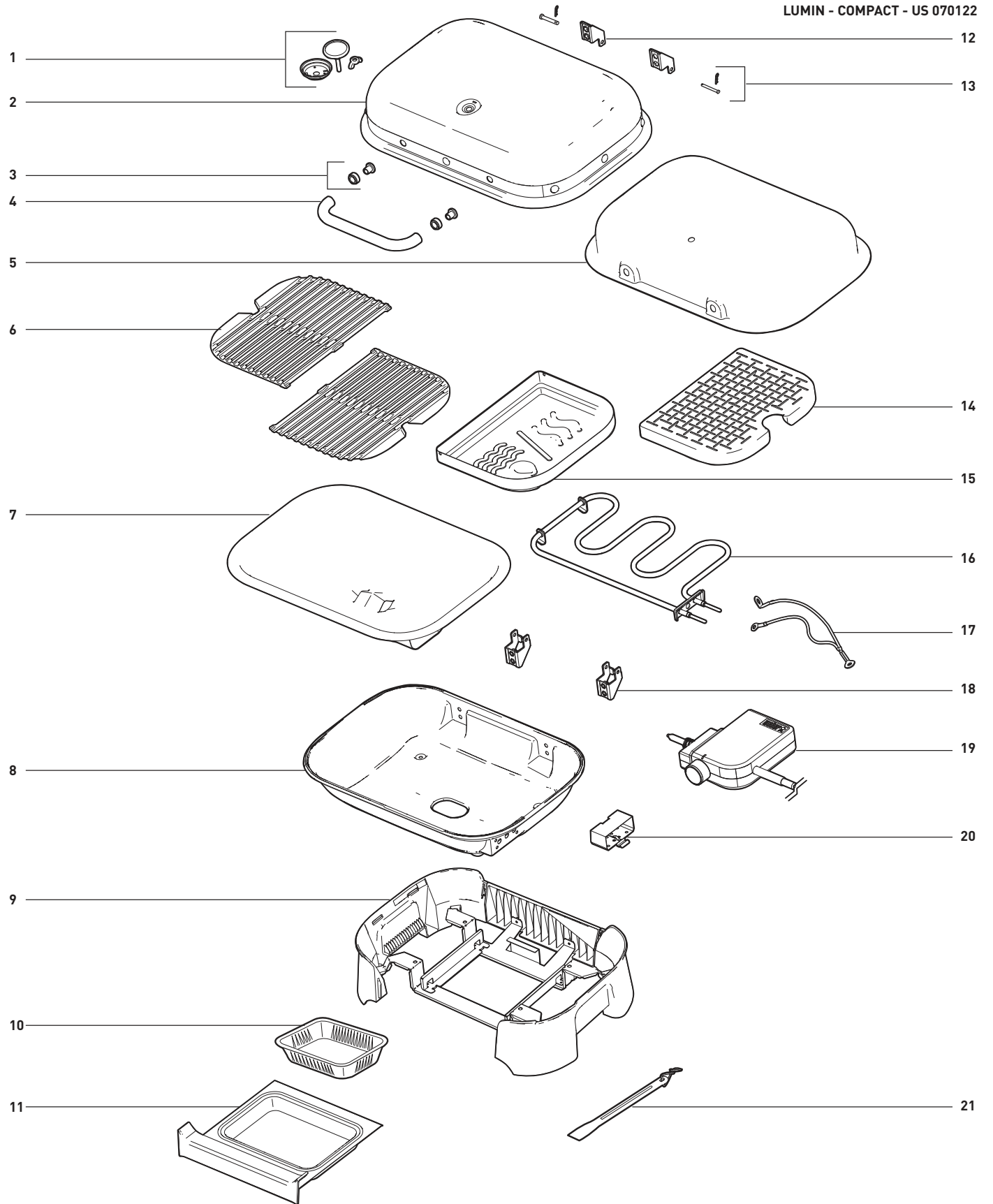



WEBER.COM



SERIAL NUMBER

Write your grill's serial number in the box above for future reference. The serial number appears on the data label that is located on the back of the grill frame.

U.S.:
1-800-446-1071

Canada:
1-800-446-1071

Mexico:
800-009-3237

weber.com

