



1000W

STICK MIXER



INSTRUCTION MANUAL

220-240V

1000W

WHSM01SS



CONTENTS

SAFETY INFORMATION

Important Safety Instructions	1 - 2
Electrical Requirements	3

SETUP AND USE

Installation Guide	3
Parts and Features	4
Stick Mixer Operation	5
Accessory Guide	6 - 9
Chopping Guide	10

CLEANING AND CARE	10
--------------------------------	-----------

TROUBLESHOOTING	11
------------------------------	-----------

WARRANTY	12 - 13
-----------------------	----------------

Figures and illustrations in this User Manual are provided for reference only and may differ from actual product appearance.

Product design and specifications may be changed without notice.

IMPORTANT SAFETY INSTRUCTIONS



DANGER

DANGER - Immediate hazards which **WILL** result in severe personal injury or death.



WARNING

WARNING - Hazards or unsafe practices which **COULD** result in severe personal injury or death.



CAUTION

CAUTION - Hazards or unsafe practices which **COULD** result in minor personal injury.



WARNING

Keep hair, hands, fingers and other body parts away from the end of the stick mixer whilst in operation.

1. Read all instructions carefully before using your new stick mixer.
2. Always turn the power off at the power outlet before you insert or remove the power plug. Remove by grasping the plug - do not pull on the cord.
3. Use handle grip and buttons only as some surfaces may become warm whilst the stick mixer is in use.
4. Do not operate stick mixer if:
 - i) the cord or plug is split, melted or damaged.
 - ii) the stick mixer has malfunctioned.
 - iii) the stick mixer has been damaged in any manner.

If any of the above incidents occur, return your stick mixer to the nearest authorised service center for examination, repair or adjustment.
5. This stick mixer is not intended to be operated by means of an external timer or separate remote-control system.
6. Close supervision is necessary when any appliance is used by or near children.
7. Any appliance that has been dropped or damaged should not be used until examined by an authorised service center.
8. Do not permit the mains supply cord or plug to touch hot objects or allow the power cord to lay across or near the end of the stick mixer.
9. If the mains supply cord is damaged, it must be replaced by the manufacturer, its service agent or a similarly qualified person in order to avoid a hazard.
10. This appliance is deemed for use indoors only.
11. Do not use harsh or abrasive cleaning agents. The outside surface may be wiped clean with a soft, damp cloth and dried thoroughly. If necessary, a mild dishwashing detergent may be applied to the cloth but not directly applied to the stick mixer.
12. Do not under any circumstances immerse the power cord, mains plug or stick mixer body in water or any other liquid.

IMPORTANT SAFETY INSTRUCTIONS

13. This stick mixer can be used by children aged from 8 years old and above and persons with reduced physical, sensory or mental capabilities or lack of experience and knowledge if they have been given supervision or instruction concerning use of the stick mixer in a safe way and understand the hazards involved.
14. Children should not play with the stick mixer.
15. Keep the stick mixer and its cord out of reach of children less than 8 years old.
16. Your stick mixer should not be unattended while in use.
17. This stick mixer should not be used in a commercial environment such as a restaurant, hotel or hostel dining room.
18. Always use this stick mixer with a power outlet of the voltage (A.C. only) marked on the back of the stick mixer.
19. Do not use the stick mixer for any purpose other than its intended use.
20. Do not place your stick mixer on or near a hot gas flame, electric element, heated oven or any hot surface.
21. Do not place the stick mixer on top of any other appliance.
22. Do not allow the power cord of this stick mixer to hang over the edge of a table or bench top.
23. Keep hands and utensils out of container while blending to reduce the risk of severe injury . A scraper may be used but must only be used when the blender is not running.
24.  **WARNING:** Do not blend hot liquids.
25.  **WARNING:** The blades are very sharp, handle with care.
26.  **WARNING:** Exercise caution when removing the attachments from the stick mixer and ensure appliance is turned off and unplugged whilst fitting attachments.

ELECTRICAL REQUIREMENTS

POWER SUPPLY CORD

1. Do not attempt to modify the power cord or plug in any way.
2. A short power supply cord is provided to reduce the risk of becoming entangled in or tripping over a longer cord.
3. If the power supply cord is too short, do not use an extension cord. Have a qualified electrician or serviceman install an outlet near the appliance.

NOTE: Neither Westinghouse nor the retailer can accept any liability for damage to the product or personal injury resulting due to failure to observe the electrical connection procedures.

INSTALLATION GUIDE

1. Carefully unpack your electric stick mixer.
2. Carefully remove packaging around the stick mixer and power cord. Do not remove warning labels.
3. Wash accessories, chopper attachments and beaker before use.

WARNING: ⚠ Do not under any circumstances immerse the stick mixer body, mains cord or mains plug in water or any other liquid.

PARTS AND FEATURES



1. Easy select variable speed control.
2. Soft touch ergonomic handle ensures a strong and comfortable grip.
3. Powerful 1000W motor chops, purees and liquefies with ease.
4. Easy release mechanism for all accessories.
5. Potato masher, whisk, blender blade, beaker and mini chopper.
6. Accessory storage base keeps your accessories together, neat and tidy.

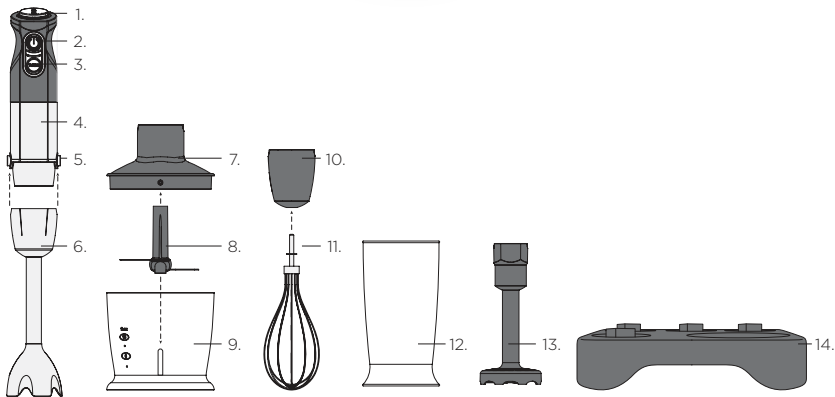

DESCRIPTION:

- | | | |
|--|---------------------------------|-------------------------------|
| 1. Variable speed control dial. | 6. Blender Blade attachment. | 12. Beaker. |
| 2. Pressure operated on/off button. | 7. Chopping bowl lid. | 13. Potato masher attachment. |
| 3. Pressure operated turbo speed button. | 8. "S" blade for chopping bowl. | 14. Accessory storage base. |
| 4. Stick mixer body. | 9. Chopping bowl. | |
| 5. Easy release mechanism. | 10. Whisk holster. | |
| | 11. Whisk attachment. | |

STICK MIXER OPERATION

1. Before first use, the accessories, chopper and beaker must be cleaned. Wash the accessories, chopper and beaker with hot water and mild detergent. Rinse with fresh water and dry thoroughly. Your stick mixer is now ready for use.
2. Ensure unit is unplugged from wall power outlet.
3. Insert required attachment into stick mixer body until it locks.
4. Ensuring your fingers are not pressing either of the buttons on the front of the unit, plug the power cord into the power outlet and switch on.
⚠ WARNING: Keep hands clear of attachments when turning unit on.
5. Add ingredients into the beaker, chopper or other approved mixing apparatus.
6. Set speed to 1 on the stick mixer using the variable speed dial on the top of the unit. It is recommended to start all processing at a this speed and increase the speed during the processing.
7. Press the on/off or turbo button to start the stick mixer.
8. After use, unplug from the wall power outlet.
9. Press the easy release buttons either side of the stick mixer body simultaneously to release attachment.



Westinghouse

Fantastic recipes for this product and many other Westinghouse appliances can be found under the recipe section at:

www.westinghousesmallappliances.com.au

BLENDER BLADE ACCESSORY

HOW TO USE THE BLENDER BLADE ACCESSORY:

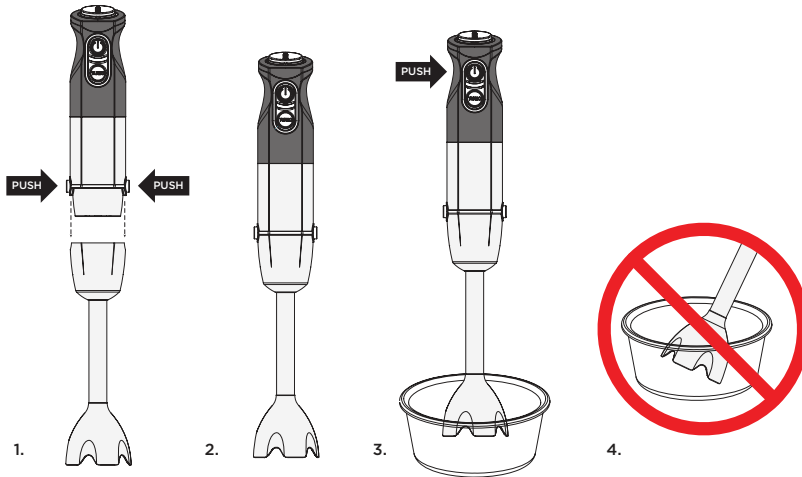

The blender blade attachment is perfectly suited for preparing dips, sauces, soups, mayonnaise and baby food. The blender blade also works well for mixing and making milkshakes.

1. Ensure stick mixer is unplugged from the wall power outlet.
2. Insert the blender blade attachment onto the body of the stick mixer until it locks. (see image 1 and 2 - above)
3. Ensuring your fingers are not depressing either of the buttons on the front of the unit, plug the power cord into the power outlet and switch on.

⚠ WARNING: Keep hands clear of attachments when turning unit on.

4. Insert the hand blender in the beaker or container being used, then press the on/off button or turbo button. (image 3 - above)

NOTE: When using, ensure the mixer is used in a vertical up and down motion. Do not use at a heavily tilted angle as this will flick contents outwards and away from your mixing container.

5. Setting the variable speed control to 1 speed is recommended to start processing at low speed.
6. Once blending has been completed, unplug from the wall socket then press the release buttons either side of the stick mixer body simultaneously to release the blender blade attachment.

Note: We recommend using the supplied beaker whilst using the blender blade attachment.

CHOPPER ACCESSORY

HOW TO USE THE CHOPPER ACCESSORY:

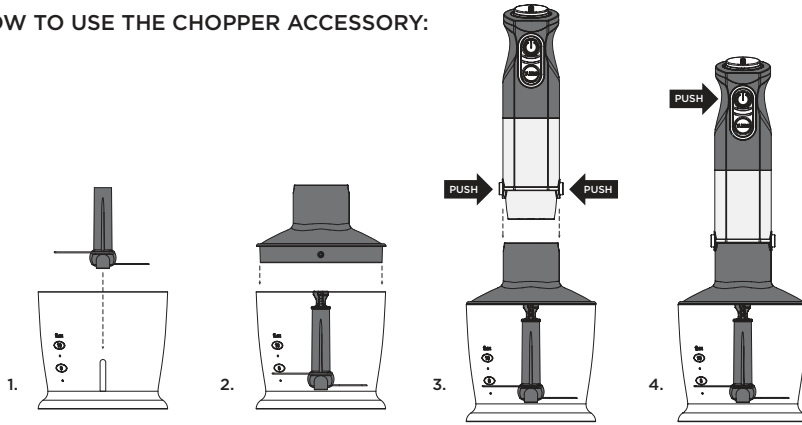

The chopper is perfectly suited for firm foods, such as chopping diced meat, cheese, onion pieces, herbs, garlic, carrots, walnuts, almonds etc.

⚠ WARNING: Do not chop extremely hard food, such as ice cubes, nutmeg, coffee beans and grains as this will cause damage to the chopper accessory and stick mixer.

NOTE: Before chopping, carefully remove the plastic cover from the chopper blade.

⚠ CAUTION: the blade is very sharp! Always handle the chopper blade by the upper plastic section.

1. Place the blade attachment into the chopping bowl onto the center locator pin and push down carefully. (insert first image above)
2. Place foods into chopping bowl.
3. Place lid onto the top of the chopper body and twist to lock the bowl. (insert second image - above) NOTE: Always place the chopping bowl onto a dry stable surface.
4. Ensure stick mixer unit is unplugged from the wall power outlet.
5. Place stick mixer body into the top of chopping bowl lid and push down gently until it locks.

Ensuring your fingers are not depressing either of the buttons on the front of the unit, plug the power cord into the power outlet and switch on.

6. Use one hand to hold the stick mixer body and the other hand to steady the chopping bowl.
7. Set the variable speed control to 1 for low speed or 5 for the highest speed.
8. Press on/off or turbo buttons to operate the chopper.
9. After use, unplug from the wall power outlet then press the release buttons on either side of the stick mixer body simultaneously to release the chopper accessory.
10. Remove the chopping bowl lid, carefully take out the chopper blade and remove the processed food from the chopping bowl.

WHISK ACCESSORY

HOW TO USE THE WHISK ACCESSORY:

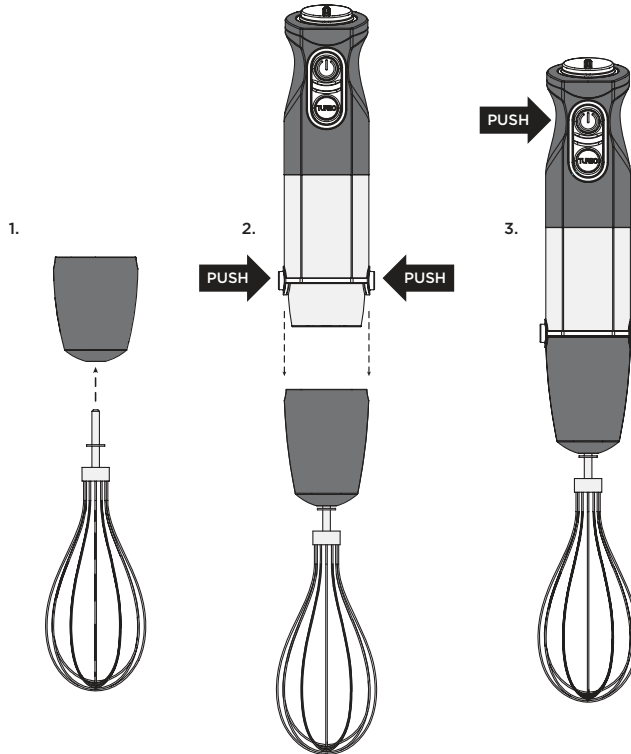

The whisk is designed for whipping cream, beating egg whites, mixing sponges and ready-mix desserts.

NOTE: It is not designed for mixing dough or other dense foods.

1. Ensure stick mixer unit is unplugged from the wall power outlet.
2. Insert the whisk attachment into the whisk holster. (image 1 above)
3. Slot the whisk attachment into the stick mixer body until it locks.
4. Ensuring your fingers are not depressing either of the buttons on the front of the unit, plug the power cord into the power outlet and switch on.
5. Set the variable speed control to 1 for low speed or 5 for the highest speed.
6. Place the whisk in a beaker or mixing container. Press the on/off or turbo button to activate the stick mixer.
7. After use, unplug from the wall power outlet then press the release buttons on either side of the stick mixer body simultaneously to release the whisk accessory.
8. Pull the whisk attachment out of the whisk holster for cleaning.

POTATO MASHER ACCESSORY

USING YOUR POTATO MASHER ACCESSORY:

The potato masher is designed to give you fast processing of lump-free light potato mash.

NOTE: Ensure potatoes are cooked and soft prior to commencing mashing.

1. Ensure stick mixer unit is unplugged from the wall power outlet.
2. Slot the potato masher attachment into the stick mixer body until it locks. (Use 1 image above.)
3. Ensuring your fingers are not depressing either of the buttons on the front of the unit, plug the power cord into the power outlet and switch on.
4. Turn stick mixer to 1 speed setting using the variable speed dial on the top of the mixer.
5. Place the potato masher into your mixing container and only then, press the on/off button to activate the stick mixer. **NOTE:** Start with lower speed and increase as necessary. Do not use turbo function.

NOTE: In order to obtain light and tasty potato mash add small amounts of hot milk and dairy butter.

6. After use, unplug from the wall power outlet and remove the blades of the potato masher for cleaning by turning the paddle blade clockwise. **NOTE:** keep potato masher attachment connected to stick mixer body during this step.
7. Once potato masher blades have been removed, press the release buttons on either side of the stick mixer body simultaneously to release the potato masher accessory.

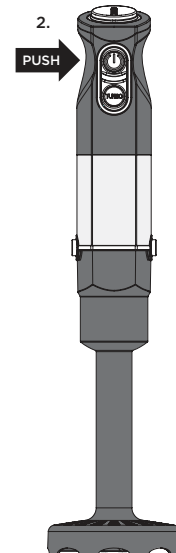
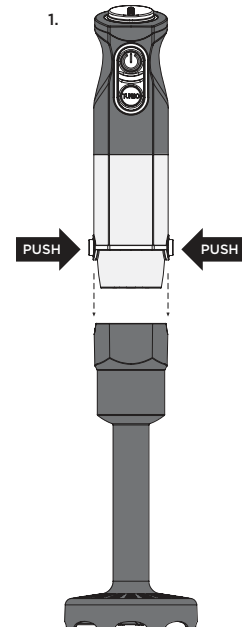

CHOPPING GUIDE

FOOD	MAXIMUM	OPERATION TIME
Meat 25cm Cubes	250g	15 sec.
Herbs	50g	10 sec.
Nuts, Almonds	150g	15 sec.
Cheese 25cm Cubes	100g	10 sec.
Bread	80g	10 sec.
Onions Chopped into 1/4	200g	10 sec.
Biscuits	150g	10 sec.
Soft Fruit	200g	10 sec.

CLEANING & CARE

1. **⚠ WARNING:** Do not under any circumstances immerse the power cord, mains plug or stick mixer body in water or any other liquid.
2. Do not use harsh or abrasive cleaning agents. The outside surface may be wiped clean with a soft, damp cloth and dried thoroughly. If necessary, a mild dishwashing detergent may be applied to the cloth but not directly applied to the stick mixer.
3. Soaking the accessories in water will assist in the removal of sticky or tough to remove substances. In most instances, running hot water over the utensils is sufficient to remove most substances.
4. When washing, non-abrasive cloths and plastic bristle kitchen brushes may be used to remove stubborn food particles from the accessories. Do not use abrasive cloths and cleaning materials as they will damage the surface.
5. Ensure all accessories are dried thoroughly after cleaning and placed back into the stick mixer storage base.
6. Store in a dry place away from steam and humidity where possible.

TROUBLESHOOTING

BEFORE CALLING FOR SERVICE

If the stick mixer fails to operate:

1. Check to make sure the stick mixer is plugged in correctly and securely. If it is not, remove the plug from the outlet, wait 10 seconds and plug it back in securely.
2. Check for a blown or tripped circuit breaker in your home. If these seem to be working correctly, test another appliance in the same outlet to ensure the outlet is working correctly.

IF NONE OF THE ABOVE SOLVES THE PROBLEM, DO NOT TRY TO ADJUST OR REPAIR THE STICK MIXER YOURSELF.

CUSTOMER SERVICE

In the event you believe your slow cooker to be defective, please return it along with your sales receipt to the place of purchase for resolution.

For any enquiries, please call our service center on: Tel: 1300 883 109

TROUBLESHOOTING

Troubleshoot your problem by using the chart below. If the slow cooker still does not operate correctly, it may be defective.

TROUBLE	POSSIBLE CAUSE	POSSIBLE REMEDY
Stick mixer does not turn on.	Stick mixer is not plugged in.	Check that stick mixer is plugged into a working power outlet and turned on.
Chopper blade not turning.	Possibly too much food in the chopper bowl.	Reduce quantity of food in the chopper bowl and try again.
Paddle blade won't remove from potato masher attachment.	Turning the blade the wrong way.	Ensure the blade is turned in a clockwise direction for removal.
Lid won't lock onto the chopping bowl.	Chopping blade gear misaligned.	Rotate the chopping blade and retry fitting the lid.
Motor slowing down and appears to be struggling while in use.	Foods are too dense or too much food in the bowl or beaker.	Reduce quantity of food and try again. Check speed level is correct for your ingredients. Refer page

LIMITED WARRANTY

1. Nothing in this Warranty affects the Consumer's rights under the Australian Consumer law. The benefits to the Consumer under this Warranty are in addition to the rights and remedies of the buyer under any Consumer Guarantees. The Australian Consumer Law requires that we confirm that:

Our goods come with guarantees that cannot be excluded under the Australian Consumer Law. You are entitled to a replacement or refund for a major failure and for compensation for any other reasonably foreseeable loss or damage. You are also entitled to have the goods repaired or replaced if the goods fail to be of acceptable quality and the failure does not amount to a major failure.
2. Subject to Clause 1, the Seller warrants that Westinghouse branded products will be free of manufacturing defects and will perform to the Seller's specifications subject to the following clauses.
3. The benefit of this Warranty extends only to the owner of the property in which the Products manufactured or supplied by the Seller are installed and used by the owner for the duration of the Warranty Period.
4. The Warranty commences on the date of the purchase of the product and continues for the benefit of the Owner for the Warranty Period. If within the Warranty Period a manufacturing defect is discovered in the Product, or the Product fails to perform to the Seller's specifications as a result of some defect in material or workmanship in the Product, then the Seller will at its own discretion:
 - a.) Repair or replace the Product at the cost of the Seller, including but not limited to labour and travel costs. Goods repaired or replaced under this Warranty will be warranted for the remaining period of the Warranty.
 - b.) Refund the purchase price paid by the consumer.
5. The Warranty does not apply to Product that :
 - a.) Has failed due to excessive wear and tear beyond what is considered to be reasonable.
 - b.) Has been misused or neglected.
 - c.) Has been damaged accidentally or by acts of God including fire and flooding.
 - d.) Has been used or operated contrary to operating or maintenance instructions.
 - e.) Has been damaged by the Consumer or a third party authorised to act for the consumer in transit from the Sellers store to the Consumer.
6. In order to make a claim under the Warranty, the Owner must, where possible return the goods to the Seller's store at the Owner's cost. Proof of purchase must be supplied in all cases.
7. The seller will examine any returned Products and if the Seller determines that there is an apparent defect through no fault of the Owner, the Seller will:
 - a.) Make note of the Owner's contact details including the Owner's telephone number which the owner can be contacted during business hours, postal address and e-mail address.

- b.) Make note of the defects reported by the Owner.
- c.) Take back the defective goods from the owner and determine within a reasonable time through dialogue with the Seller whether the goods are defective.
- d.) Advise the owner within a reasonable time frame whether it accepts or rejects the Product claim.
- e.) If the Seller accepts the return of the Product, the Seller must arrange to have
 - i) The Product repaired or,
 - ii) Replace the damaged or faulty Product or,
 - iii) Refund the purchase price.
- 8. The Seller will not accept any returned Product which has not been returned strictly in accordance with this Warranty.
- 9. For the purpose of this Warranty:
 - a.) Australian Consumer Law means the law as set out in Schedule 2 of the Competition and Consumer Act 2010 (Cth).
 - b.) Consumer means the Purchaser of goods from the seller.
 - c.) Consumer means a Consumer as that term is set out in section 3 of the Australian Consumer Law.
 - d.) Consumer Guarantees means the guarantees under the Australian Consumer Law.
 - e.) Implied terms means any guarantees, conditions, warranties or other terms implied by any Australian Commonwealth, State or Territory laws, (excluding the Australian Consumer Law) or the law of any other jurisdiction.
 - f.) Owner has the meaning set out in clause 3.
 - g.) Warranty means this warranty.
 - h.) Product means the Product/s bought by the Owner from the Seller that fall under this warranty.
 - i.) Warranty Period means:
 - i) In relation to Cast Iron Cookware: 3 Year Limited Warranty.
 - ii) In relation to Non-Stick Cookware: 3 Year Limited Warranty
 - iii) In relation to Cooking Utensils: 3 Year Limited Warranty
 - iv) In relation to Knives/Knife Block Sets: 3 Year Limited Warranty
 - v) In relation to Stainless Steel Cookware: 10 Year Limited Warranty
 - vi) In relation to Chopping boards: 1 Year Limited Warranty
 - vi) In relation to Small Appliances: 1 Year Limited Warranty



Westinghouse

INNOVATION YOU CAN BE SURE OF

CUSTOMER SERVICE - 1300 883 109

IMPORTED AND DISTRIBUTED BY RVM AUSTRALIA PTY LTD.
11 Tamara Drive, Cockburn Central, WA 6164
MADE IN CHINA

© 2015 RVM AUSTRALIA PTY LTD. ALL RIGHTS RESERVED.

Ⓜ, WESTINGHOUSE, and INNOVATION YOU CAN BE SURE OF
are trademarks of Westinghouse Electric Corporation.
Used under license by RVM AUSTRALIA PTY LTD. ALL RIGHTS RESERVED.