

HECKUMBAU

Rear conversion | Modification arrière | Conversione posteriore | Modificación trasera

Art.-Nr: 13615-00x

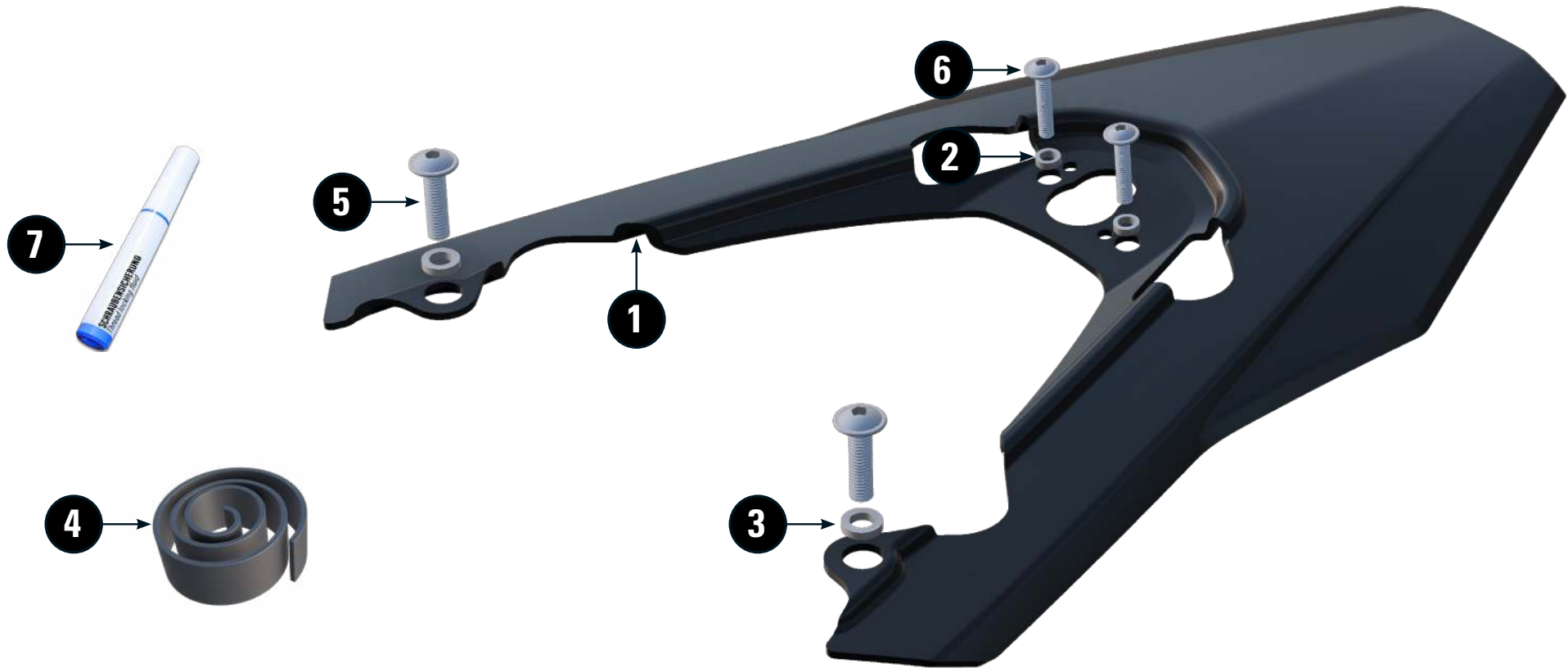

#	Bauteil component composant	DE Die Farben der Abbildungen dienen nur der Veranschaulichung. EN The colors are for illustrating purposes only. FR Les couleurs utilisées sont à titre indicatif seulement.	DIN	ISO	Menge quantity quantité
1	Abdeckung / Cover				1
2	Hülse / Sleeve	D=10 d=6,4 l=3mm			2
3	Hülse / Sleeve	D=14 d=8,4 l=3mm			2
4	Moosgummi / Foam rubber				1m
5	Linsenflanschschraube / Lens flange screw	M8x30	7381	7381	2
6	Linsenflanschschraube / Lens flange screw	M6x30	7381	7381	2
7	Schraubensicherung / Thread locking fluid				1

LEGENDE/KEY/FILE LÉGENDE

Anbau Tipp
Fitting tip
Astuce de montage

Achtung
Attention
Attention

Vergrößerung
Magnification
Grossissement

Montagepaste
Fitting lubricant
Lubrifiant de montage

Schraube
Screw
Vis

Schraubensicherung
Thread locking fluid
Freinfilets

Drehmoment
Torque
Torque

Reiniger
Cleaner
Nettoyant



Vor der Montage des Heckumbaus müssen der originale Griff, der Sportgriff sowie der Topcaseträger demontiert werden. (Bild 1,2,3).
Before installing the rear conversion, the original grab handle, the sport grab handle, and the top case carrier must be removed. (see images 1, 2, 3). Avant de monter la modification arrière, la poignée d'origine, la poignée sport ainsi que le support de top-case doivent être démontés (voir images 1, 2, 3).



5

Das Moosgummi auf der Unterseite der Abdeckung wie im Bild gezeigt kleben. Zu beklebende Flächen vorher gründlich reinigen.

Stick the foam rubber to the underside of the cover as shown in the picture. Thoroughly clean the surfaces to be bonded beforehand. Collez la mousse sur la face inférieure du couvercle comme indiqué sur l'image. Nettoyez soigneusement les surfaces à coller au préalable.

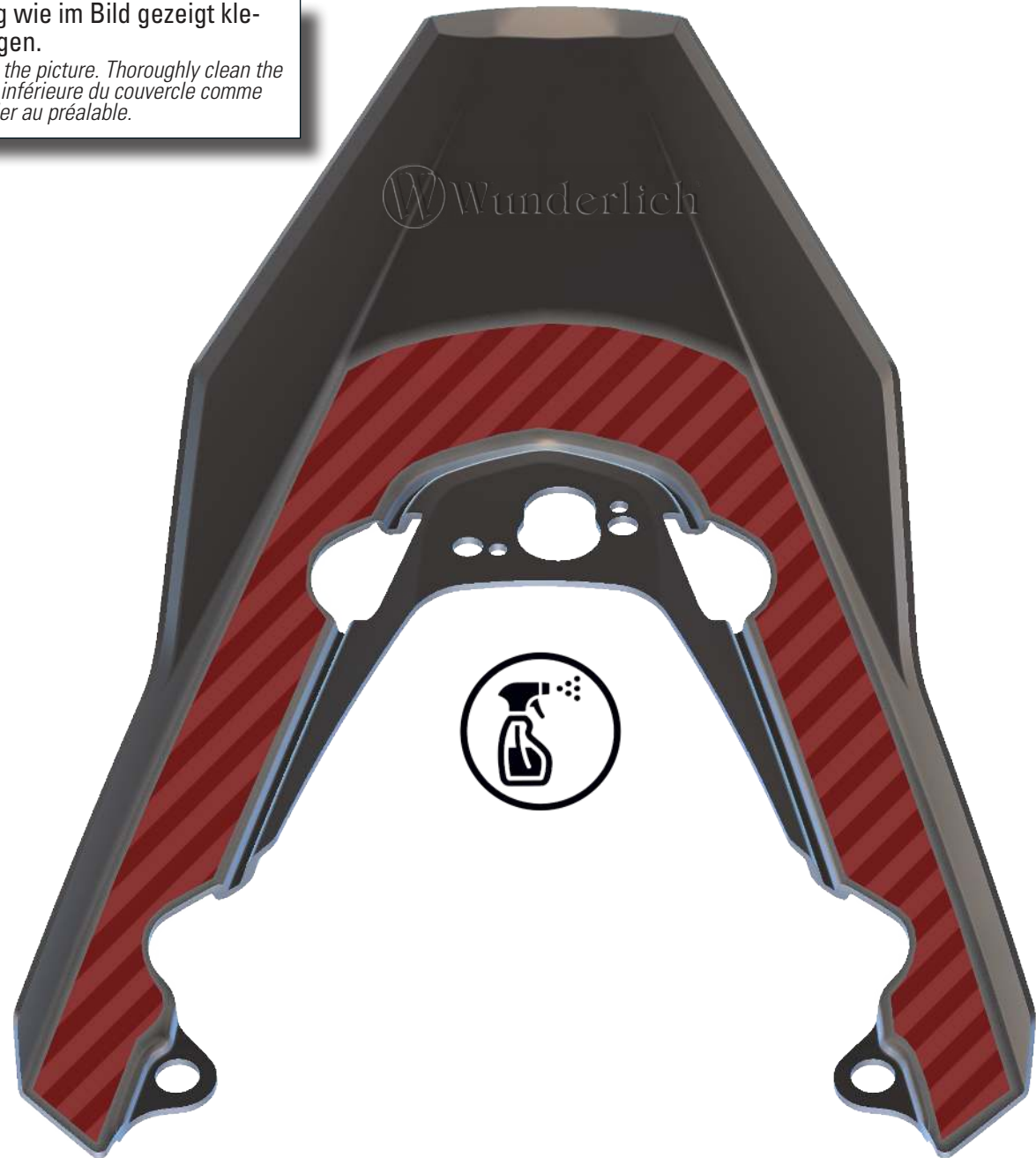
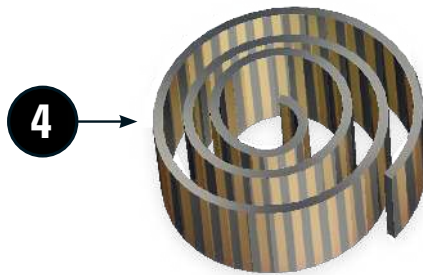

3

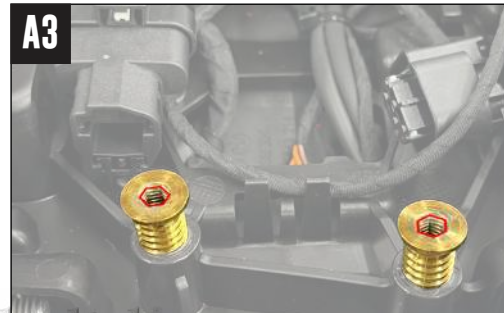
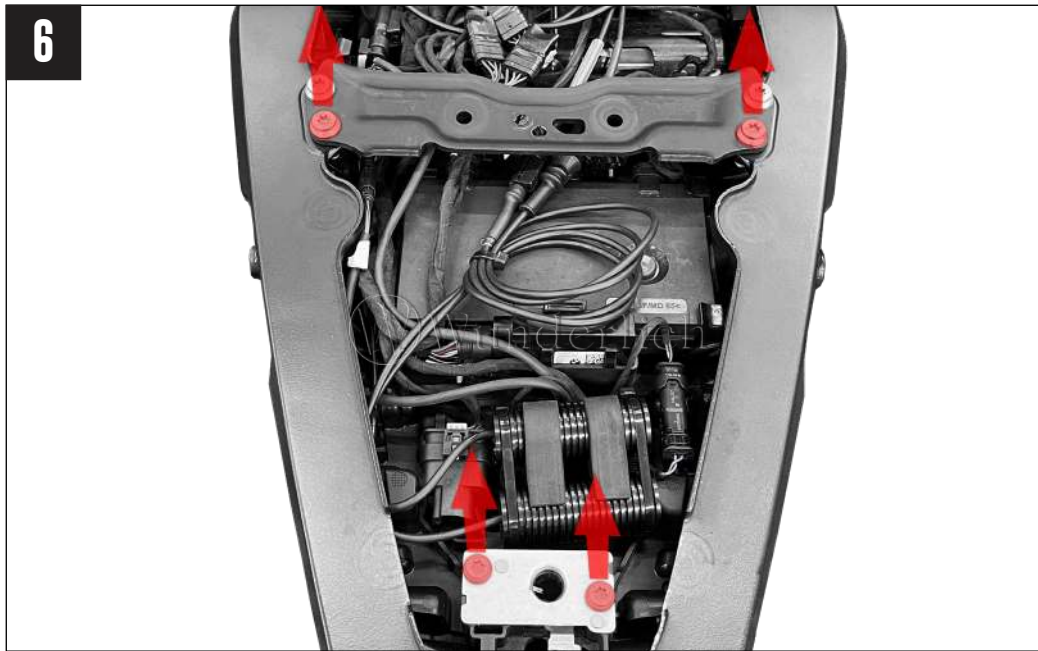

Beim Abschrauben des Sitzbankschlusses können sich die Gewindehülsen lösen. In diesem Fall die Gewindehülsen mit einem 5-mm-Innensechskantschlüssel wieder eindrehen. When unscrewing the seat lock, the threaded sleeves may come loose. In this case, screw the threaded sleeves back in using a 5 mm Allen key. Lors du dévissage de la serrure de selle, les douilles filetées peuvent se desserrer. Dans ce cas, revisser les douilles filetées à l'aide d'une clé six pans creux de 5 mm.

