



Read this manual carefully before use, and retain it for future reference.

The rice cooker is for household use only.

Precautions

Usage restrictions

- Keep the rice cooker away from children.
- The normal operating altitude range of the rice cooker is 0–2000 meters.
- Do not place the rice cooker on unstable or wet surfaces. Keep it away from fire or heat sources (such as stoves), preferably 30 cm or more.
- Do not place the rice cooker near devices that are susceptible to electromagnetic interference.
- Do not use a non-dedicated or deformed inner pot to prevent burns and injuries as a result of overheating.

Cleaning & maintenance

- Do not immerse the rice cooker in water or splash it with water.
- Do not use steel wool or other hard objects to clean or scrub the inner pot.
- Use only soft cloths for cleaning.

AC Power Cord

- Use only the supplied AC power cord.
- Unplug the power cord before repairing and moving the rice cooker.
- If the supply cord is damaged, it must be replaced by a special cord or assembly available from the manufacturer or its service agent.
- Do not bend, pull or twist the power cord, otherwise its core may be exposed or may break.
- Do not use the supplied power cord with any other device.

Precautions for using power supply

- Do not use any power supply other than 220–240 V AC to avoid fire and electrical shocks.
- Always unplug the rice cooker by holding the power plug. Do not pull the AC power cord to avoid electric shocks or short circuit fire.

- Do not allow children to use the rice cooker unsupervised, and keep it out of the reach of infants to prevent electric shock, burns, or other injuries.
- Do not plug or unplug the power cord with wet hands, so as to avoid electric shock or injuries.

About the environment

- Steam and heat may damage, discolor or deform your walls and furniture, so keep the product preferably at least 30 cm away from any walls and furniture.
- When using the rice cooker in a kitchen cabinet, etc., please ensure that the place is well ventilated.

While in use

- Do not use the inner pot on any other heat sources, such as an induction rice cooker or gas stove.
- Do not place the inner pot and accessories in the dishwasher for cleaning.
- Do not insert anything into the steam outlet or gaps to avoid electric shocks or injuries.
- Do not touch the inner pot directly by hand during and immediately after use to avoid high-temperature burns.
- Do not touch the steam outlet during or immediately after use. Keep away from children and infants and take special precautions to prevent them from being scalded.
- Do not move or shake the rice cooker during use.
- Do not use this rice cooker to prepare food that may clog the steam valve (such as seaweed and kelp).
- Do not cover the steam valve of the rice cooker with other items when in use to avoid the inability of steam release.
- If rice is left in the rice cooker in the keep warm mode for more than 12 hours, it will have a peculiar smell.
- This appliance is not intended for use by persons (including children) with reduced physical, sensory or mental capabilities, or lack of experience and knowledge, unless they have been given supervision or instruction concerning use of the appliance by a person responsible for their safety for IEC60335.
- Children should be supervised to ensure that they do not play with the appliance for IEC60335.

- This appliance can be used by children aged from 8 years and above if they have been given supervision or instruction concerning use of the appliance in a safe way and if they understand the hazards involved. Cleaning and user maintenance shall not be made by children unless they are older than 8 and supervised. Keep the appliance and its cord out of reach of children aged less than 8 years for EN 60335.
- Appliances can be used by persons with reduced physical sensory or mental capabilities, or lack of experience and knowledge if they have been given supervision or instruction concerning use of the appliance in a safe way and understand the hazards involved for EN 60335.
- Children shall not play with the appliance for EN 60335.

After use

- After use, always remember to turn off the rice cooker and unplug the power cord.
- Regularly check the steam outlet to make sure it is not clogged.
- Immediately stop using and unplug this product if there is any error or it malfunctions. Remove the inner pot only when it has cooled off.

Additional precautions

- Do not drop the rice cooker or hit it with hard objects to prevent injuries or malfunction.
- Do not use the rice cooker when the inner set is damaged to avoid scalds or injuries caused by steam or boiling object leaks.
- Do not modify the unit.
- Only a repair technician may disassemble or repair the product, in order to prevent the risk of fire, electric shocks, and injuries.
- Immediately stop using this product if there is any error or malfunctions to prevent fire, electric shocks or other injuries.
- Avoid the silicone parts of the product getting contact with alcoholic beverages with an alcohol content greater than 50%.

CAUTION: The surface of the heating elements will have residual heat after use.

CAUTION: Incorrect usage of the rice cooker may result in injuries.

CAUTION: Do not splash liquid onto the connector.

Product Overview

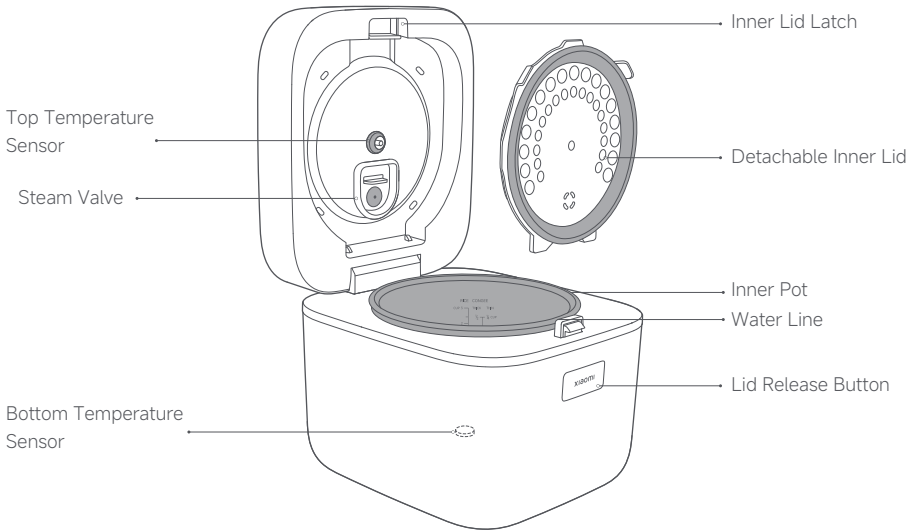

Illustrations of product, accessories, and user interface in the user manual are for reference purposes only. Actual product and functions may vary due to product enhancements.

Control Panel



1. The scheduling indicator blinks, indicating that the rice cooker is in timer setting status. Press the timer button to adjust your desired schedule time.
2. The scheduling indicator keeps on, indicating that the rice cooker is in timer countdown mode. Cooking completes after the countdown ends.

Note: The timer countdown counts the cooking completion time instead of the cooking start time.

Accessories



Rice Paddle



Measuring Cup



Power Cord



Before using the rice cooker for the first time, run the rice mode with water for 2 or 3 cycles to effectively eliminate any unpleasant odors.

How to Use

Before using the rice cooker, plug the power cord into the power port in the lower portion of the rice cooker, and plug the other end into an AC outlet.

Start cooking

1. Open the lid

Press the lid release button to open the upper lid.

Note: When you need to remove the inner pot, gently push back the upper lid to fully open it. Avoid contacting with the inner lid when removing the inner pot.

2. Add rice and water

Using 2 cups of northeastern rice as an example, add 2 measuring cups of rice into the pot, then add water up to number 2 of the water line for rice. When adding water, do not exceed the water line for the corresponding number of cups of rice to prevent the rice cooker from overflowing or a possible short circuit.

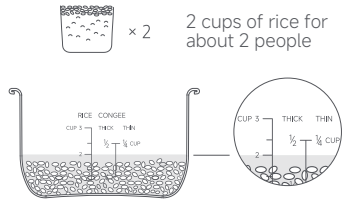

3. Setting menu

After the rice cooker is connected to power, press the select button to select one from the rice, quick rice, congee, stew, and keep warm modes.

4. Start cooking

Press the start button to start the cooking mode.

WARNING: The rice mode and the quick rice mode are for rice cooking only. Do not cook other foods in these two modes. Otherwise, it may result in scalds and damage to the product performance.

5. Cancel

Press the cancel button to cancel cooking or scheduling in the cooking mode.

6. Schedule

After selecting a cooking mode (e.g. rice), press the timer button to set the time needed from the present to the completion of cooking.

For example, if you intend to enjoy your meal in 10 hours, set the timer to show as 10:00.

Note: The desired completion time needs to be later than the current time plus the cooking time, otherwise cooking will start immediately.

7. Off mode

After the rice cooker is connected to power, the display will show "----" if no action is taken within 5 minutes. The screen will turn off after another 5 minutes, indicating that the rice cooker is in Off mode. Simply press any button to wake up the rice cooker.

Cooking modes

Press the select button to navigate to a desired cooking mode. Each time you press the button, the cooking mode will be switched in sequence of rice, quick rice, congee, stew, and keep warm.

1. Rice

The rice mode is the default cooking mode upon startup. The cooking time of the rice mode is 1 hour.

2. Quick rice

The cooking time of the quick rice mode is 30 minutes.

3. Congee

The cooking time of the congee mode is 1 hour and 30 minutes.

4. Stew

The cooking time of the stew mode is 1 hour.

5. Keep warm

After the cooking is completed, the rice cooker will automatically enter this mode, maintaining the temperature at about 73°C for 12 hours.

Specifications

Name: Rice Cooker	Model: MFB05M0-2
Rated Voltage: 220-240 V~	Rated Frequency: 50-60 Hz
Rated Power: 320-380 W	Material of Inner Pot: Aluminum Alloy
Rated Capacity of Rice: 0.48 L	Rated Capacity of Water: 1.5 L
Item Dimensions: 196 × 221 × 181 mm	

Care & Maintenance

1. Disassembling the inner lid

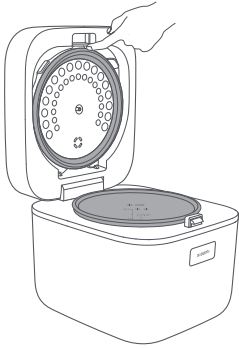

a. Push the inner lid latch upwards until the inner lid pops out automatically.

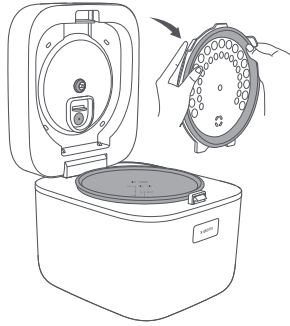

b. Hold the inner lid with both hands and remove it.

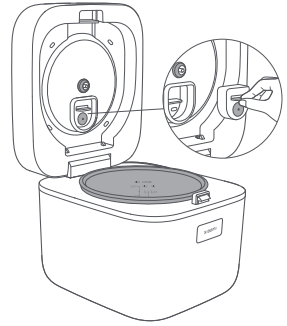

c. You can see the steam valve after removing the inner lid. Pinch the steam valve with a hand and pull it out.

Note: Clean the inner lid and steam valve after every use.

2. Assembling the inner lid

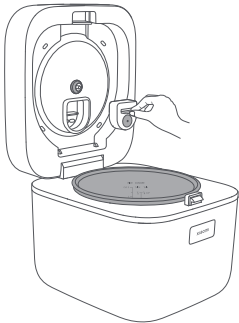

a. Align the steam valve with the steam vent and slowly press it in place.

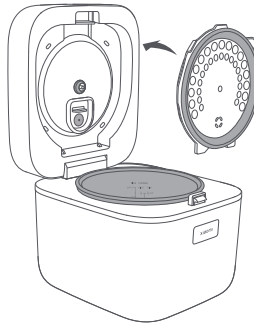

b. Insert the inner lid clip into the inner lid slot of the rice cooker, and gently push the inner lid in place.

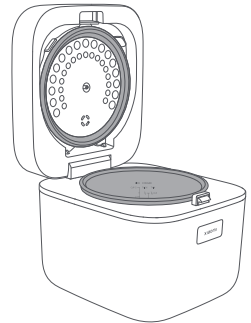

c. Fasten the inner lid with the upper latch to complete the installation.

Error Codes

Code	Error Description	Notes
E-09	The top sensor is damaged.	Contact after-sales service.
E-10	The bottom sensor is damaged.	Contact after-sales service.

Troubleshooting

Issues	Possible causes	Solutions
Unable to close the upper lid.	Check whether the inner lid is properly installed.	Install the inner lid correctly.
Rice is half-cooked (undercooked).	The ratio of rice and water may not be as required (less water). Rice may not be taken in a flat cup (excessive rice).	Follow the operating instructions given in the user manual.
Overflows while cooking rice or congee.	Misapply the cooking mode when cooking congee. Rice and water are not added in proportion (excessive water). There are foreign objects at the outer bottom of the inner pot.	Follow the operating instructions given in the user manual. Remove foreign objects.
There is an odor during cooking process.	There is residual food or accumulated water on the steam valve or inner lid.	At first use, using the steam mode to boil water for 30 minutes 2-3 times can effectively remove peculiar smells. Clean the steam valve or inner lid. Follow the instructions to boil water.
The rice on the bottom is scorched.	The rice has not been cleaned thoroughly. There are foreign objects at the outer bottom of the inner pot.	Clean the rice thoroughly. Remove foreign objects.
The rice dries out or gives off a peculiar smell in the keep warm mode.	The keep-warm time exceeds 12 hours. There are foreign objects at the outer bottom of the inner pot.	The keep-warm time should not exceed 12 hours. Remove foreign objects.

Note: If the above problems cannot be solved, please contact the after-sales service team.



Hereby, Chunmi Technology (Shanghai) Co., Ltd. declares that this equipment type Rice Cooker MFB05M0-2 is in compliance with the applicable Directives and European Norms, and amendments.

The full text of the EU declaration of conformity is available at the following internet address:

<http://www.mi.com/global/service/support/declaration.html>

For detailed e-manual, please go to www.mi.com/global/support/user-guide.



All products bearing this symbol are waste electrical and electronic equipment (WEEE as in directive 2012/19/EU) which should not be mixed with unsorted household waste. Instead, you should protect human health and the environment by handing over your waste equipment to a designated collection point for the recycling of waste electrical and electronic equipment, appointed by the government or local authorities. Correct disposal and recycling will help prevent potential negative consequences to the environment and human health. Please contact the installer or local authorities for more information about the location as well as terms and conditions of such collection points.



We Chunmi Technology (Shanghai) Co., Ltd., hereby, declares that this equipment is in compliance with the applicable Legislation. The full text of the UK declaration of conformity is available at the following

internet address:

<https://www.mi.com/uk/service/support/declaration.html>

Manufactured for: Xiaomi Communications Co., Ltd.
Manufactured by: Chunmi Technology (Shanghai) Co., Ltd.
(a Mi Ecosystem company)

Address: Building 11, 1333 Jiangnan Avenue, Changxing Science and Technology Park, Lingang, 201203 Shanghai, PEOPLE'S REPUBLIC OF CHINA
Made in China

For further information, please go to www.mi.com

User Manual Version: V1.1



使用產品前請仔細閱讀本說明書，並妥善保管。本產品僅限於家庭使用。

注意事項

使用限制

- 本產品應放置在兒童無法觸及的地方。
- 產品正常運作海拔高度範圍為 0 米至 2000 米。
- 產品不應放在不平衡、潮濕或靠近其他火源、熱源（如爐具）的地方，距離最好是 30 厘米以上。
- 請勿將產品放在容易受電磁干擾的裝置附近。
- 請勿使用非專用內鍋或變形後的內鍋，以免過熱而導致燙傷或受傷。

清潔保養時

- 器具不得浸入水中或向淋水。
- 請勿使用鋼絲球等硬質物品，清洗或擦洗內鍋。
- 請使用軟布進行清洗。

交流電源線

- 請僅使用盒內提供的交流電源線。
- 執行維護作業或移動前，請從交流電源插座，斷開交流電源線的連接。
- 執行維護作業或移動前，請從交流電源插座，斷開交流電源線的連接。
- 請勿過度擰捏、彎曲或扭轉交流電源線，否則線芯可能會暴露於外或折斷。
- 請勿在任何其他裝置上，使用所提供的交流電源線。

電源注意事項

- 禁止使用交流 220-240 V 以外的電源，以免造成火災或觸電。
- 斷開交流電源線連接時，務必手握電源插頭，然後拔下電源。請勿拉扯交流電源線，以免造成觸電或短路起火。
- 請勿允許兒童獨自操作使用，並放在嬰幼兒無法觸及的地方，以免觸電、燙傷或其他意外。
- 請勿以濕手插入或拔除電源插頭，以免觸電或受傷。
- 請單獨使用額定電流 10 A 以上的帶接地線插座，以免引起火災等危險。

關於環境

- 因蒸氣和熱量會導致牆壁及家具受損、變色或變形，因此使用時請距離牆壁和家具 30 厘米以上。
- 放入廚房壁櫃等地方使用時，應注意保持通風。

正在使用

- 請勿將內鍋放在其他熱源上加熱（如電磁爐和燃氣爐）。
- 請勿將內鍋及配件放置於洗碗機內清洗。
- 請勿在排氣孔或縫隙間插入任何物件，以免觸電或受傷。
- 使用中或剛使用結束後，請勿用手直接接觸內鍋，以免高溫燙傷。
- 使用中或剛使用結束後，切勿將身體靠近蒸氣口處。特別注意切勿讓嬰幼兒靠近，以免導致燙傷。
- 產品工作中，請勿移動或晃動。
- 切勿利用此煲煮可能導致排氣孔堵塞的食物（如紫菜或海帶等片狀食物）。
- 使用時，嚴禁以其他物品覆蓋電飯煲破泡器，以免無法釋放蒸氣。
- 本裝置不適合生理、感知或智力能力不足，或缺乏經驗和知識的人士（包括兒童在內）使用，除非其安全負責人以 IEC60335 標準向其提供有關使用本裝置的監督或指導。
- 請務必監管兒童，保證他們不將符合 IEC60335 標準的裝置用作玩具。
- 若 8 歲及以上兒童已接受該裝置安全使用的監督或指導，並已知悉涉及多個危險，則可使用該裝置。除非兒童已超過 8 歲且有人監督，否則不得進行清潔和維護。為了符合 EN 60335 標準，請將本裝置及電源線放置在 8 歲以下兒童無法接觸的地方。
- 存在生理、感知或智力能力不足，或缺乏經驗和知識的人士，可以在接受有關安全使用本裝置的監督和指導，並知悉 EN 60335 相關風險下使用本裝置。
- 根據 EN 60335 標準，兒童不得將本裝置當作玩具使用。

使用結束

- 不使用時，切記關閉電源，並拔除電源插頭。
- 必須定期檢查蒸氣排出管道，確保沒有堵塞。
- 若產品出現異常或故障時，請立即停止使用，並拔除電源插頭。需要待冷卻後，方可開蓋和取出內鍋。

其他注意事項

- 請勿摔落本產品或碰撞堅硬物，以免造成受傷或故障。
- 請勿在內蓋結構損壞的情況下使用，以免因蒸氣、煮沸洩露造成燙傷或受傷。
- 請勿改造。
- 非維修技術人員，不可拆卸或修理，以免造成火災、觸電及受傷。
- 發生異常或故障時，立即停止使用，以免造成火災、觸電及受傷。
- 產品的矽膠件避免與乙醇含量超過 50% 的酒精飲品接觸。
- 注意：使用後，加熱零件表面仍然有餘溫。
- 注意：不正確使用本產品可能會導致受傷。
- 注意：請避免液體噴濺連接頭。

產品介紹

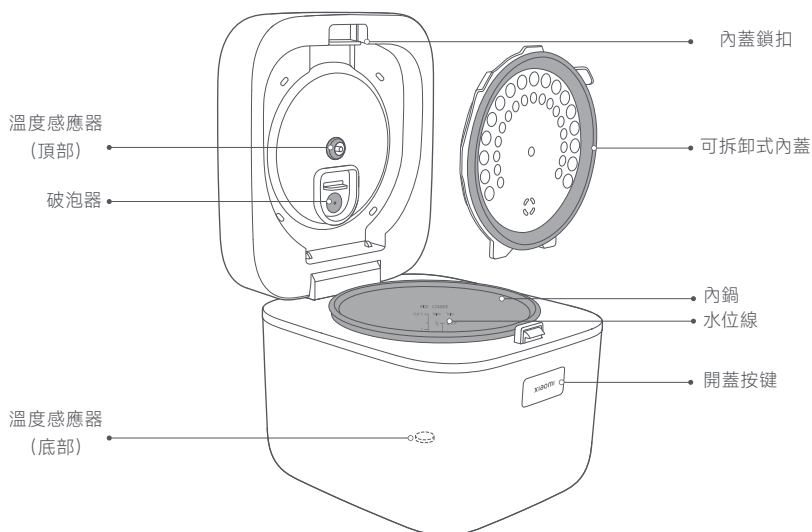

提示：說明書中的產品、配件、使用者介面等插圖均為示意圖，僅供參考。由於產品的更新與升級，產品實物與示意圖可能略有差異，請以實物為準。

控制面板

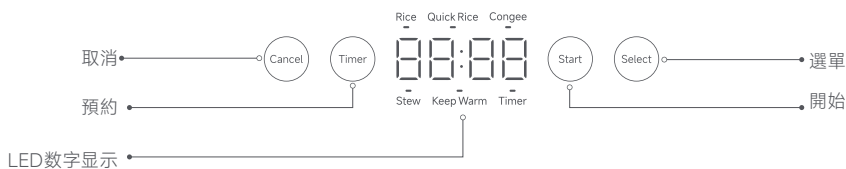

1. 「預約中」燈光閃爍，即電飯煲進入預約設定狀態。按「預約」鍵，則調節所需預約時間；
2. 「預約中」燈光長亮，即電飯煲進入預約倒計時。待倒計時結束後，便完成煮飯。

提示：預約倒計時是烹飪完成時間，並非烹飪開始時間。

配件清單圖示



飯勺×1



量杯×1



電源線×1



首次使用產品前，請使用「精煮飯」模式煮清水 2 至 3 次，可有效減少異味。

使用

將電源線連接至主機底部的電源接口，然後將電源線另一端插入交流電插座，即可開始使用。

開始煮飯

1. 開蓋

按開蓋按鍵，打開上蓋。

提示：如需取出內鍋，請輕推上蓋，充分打開。取出內鍋時，請避免碰撞到內蓋。



2. 放米放水

以煮 2 杯東北米為例，加水至相應刻度 2。加水時，切勿超過相應水位刻度線，否則可能引起溢鍋或短路等故障。

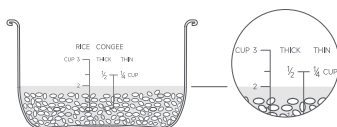

3. 設定選單

電飯煲通電後，按「選單」鍵，選擇「精煮飯」、「超快飯」、「煲粥」、「燉煮」、「保溫」模式。

4. 開始煮飯

按「開始」按鍵，進入烹飪狀態。

警告：「精煮飯」和「快煮飯」擋，僅適用於米飯。請勿用於其他烹飪方式，否則會導致燙傷及損害產品效能。

5. 取消

烹飪狀態下，按「取消」鍵，取消烹煮或預約。

6. 預約

選擇烹煮模式後（以「精煮飯」為例），按「預約」鍵，然後設定目前時間至烹煮完成所需的時間。

例如：預計十小時後開飯，則需要將預約時間設定為 10:00。

提示：目前時間至預約完成時間，需要比烹煮時間長，方可預約成功。否則，便會立即開始烹煮。

7. 关机模式

電飯煲通電後，如 5 分鐘內無操作，屏幕便會顯示「----」。5 分鐘後，關閉屏幕。此時為关机模式，可按任何按鍵，即可喚醒電飯煲。

選單

按「選單」鍵，選擇想使用的模式。每按一次「選單」鍵便會按「精煮飯」、「超快飯」、「煲粥」、「燉煮」、「保溫」順序依次切換。

1. 精煮飯

開機預設為「精煮飯」模式，精煮飯烹飪需時 1 小時。

2. 超快飯

超快飯烹飪需時 30 分鐘。

3. 煲粥

煲粥烹飪需時 1 小時 30 分鐘。

4. 燉煮

燉煮烹飪需時 1 小時。

5. 保溫

烹飪完成後，電飯煲自動進入保溫模式，保溫溫度維持在 73°C 左右。保溫時間為 12 小時。

基本規格

產品名稱	電飯煲	產品型號	MFB05M0-2
額定電壓	220-240V~	額定頻率	50-60 Hz
額定功率	320-380W	內鍋材質	合金
額定米容量	0.48 L	額定水容量	1.5 L
產品尺寸	196 × 221 × 181mm		

維護與保養

1. 內蓋拆卸

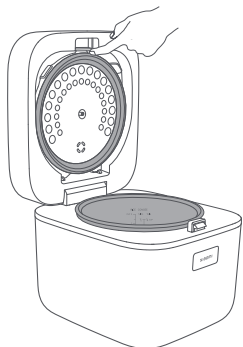

a. 向上推動內蓋鎖扣使內蓋自動彈出

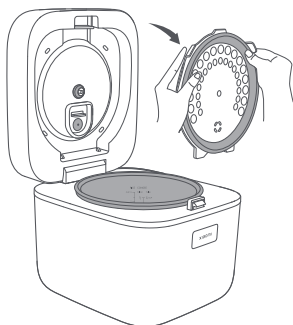

b. 雙手捏住內蓋將其取下

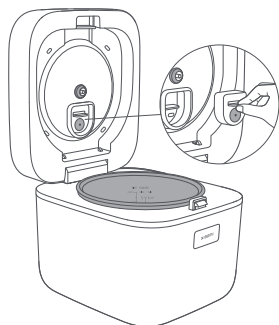

c. 拆除內蓋後可見破泡器，單手捏住破泡器向外拉出。

提示：請每次烹飪結束後清洗內蓋和破泡器

2. 內蓋安裝

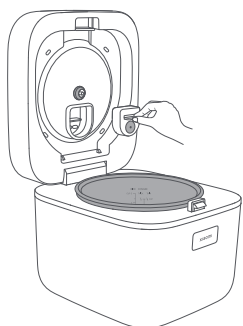

a. 破泡器口對準蒸氣口安裝位置向安裝口慢慢壓入

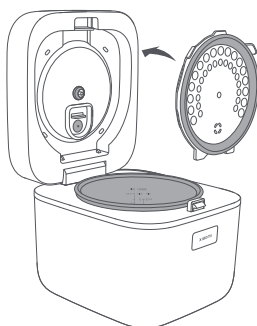

b. 內蓋卡扣插入電飯煲內蓋卡槽後，輕輕推入

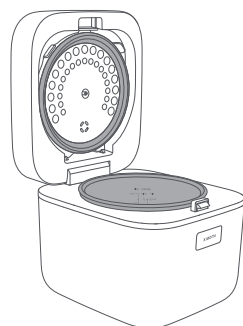

c. 上方鎖扣把內蓋扣住，安裝完畢

故障代碼

代碼	故障描述	備註
E-09	頂部感應器損壞	請聯絡售後服務
E-10	底部感應器損壞	請聯絡售後服務

疑難排解

故障類型	可能原因	解決方法
上蓋無法合上	請檢查內蓋是否安裝妥當	內蓋安裝妥當
飯夾生（未煮熟）	米水比例是否達至刻度（水偏少） 取米是否為平杯（米太多）	根據說明書提示操作
煮飯煲粥時溢出	煲粥時，錯用烹煮選單 米和水未按比例放置（水偏多） 內鍋外底部有異物	根據說明書提示操作 去除異物
煮飯過程冒異味	破泡器或內蓋有殘留食物或積水 首次使用產品時，請使用蒸煮功能煲水 30分鐘2至3次，可有效去除異味	清洗破泡器或內蓋 按提示煲水
米飯底部焦黃	米未淘洗乾淨 內鍋外底部有異物	米淘洗乾淨 去除異物
保溫後，米飯變硬 或有異味	保溫時間超過 12 小時 內鍋外底部有異物	保溫時間不宜超過 12 小時 去除異物

提示：如果以上問題仍未獲得解決，請聯絡售後服務。

委託商：小米通訊技術有限公司
製造商：純米科技（上海）股份有限公司
（小米生態鏈企業）
製造商地址：上海臨港長興科技園江南大道1333弄11號樓
服務電話：852-30773620
本產品售後服務請查詢官網：www.mi.com/hk/service
中國製造
本產品的相關訊息請查詢銷售網址：www.mi.com
說明書版本號：V1.1

EU REP.
Xiaomi Technology Netherlands B.V.
Prinses Beatrixlaan 582, 2595BM, The Hague, The Netherlands
contact@support.mi.com
UK REP.
Xiaomi Technology UK Limited
Davidson House, Forbury Square, Reading, Berkshire RG1 3EU
contact@support.mi.com

