

**USER MANUAL: OPTIMA-33 T10**

**208/120V: 10K/20K/30K/40K**

**400/230V: 10K/20K/30K/40K/60K/80K**

**480/277V: 10K/20K/30K/40K/60K/80K**

**3-PHASES INPUT / 3-PHASES OUTPUT**

**ONLINE DOBLE CONVERSION UPS**

**MODELS: (208/120V)**

**(400/230V)**

**(480/277V)**



- 
- Technical information on this manual is property of XMART ®. This manual Information cannot be copied or distributed totally or partially without written approval of XMART.
  - XMART can introduce modifications in their products or manuals without further notice.
  - XMART is not responsible of mistakes or missing information in this manual.
  - XMART is not responsible for wrong use a third part can do of this information.
  - Trademarks and logos in this manual are property of their owners.
-

**TABLE OF CONTENTS****1.- GENERAL SAFETY INSTRUCTIONS****2.- PRODUCT DESCRIPTION & AVAILABLE MODELS****3.- INTERNAL BLOCKS DIAGRAM****4.- PRINCIPLES AND OPERATION MODES****5.- INSTALLATION: SITE CONDITIONS REVISION****SITE PLANING****UPS INSTALLATION****EXTERNAL PROTECTION SELECTION****WIRES SELECTION****6.- SINGLE UPS WIRING: TERMINAL BLOCK & EXTERNAL BATTERIES****7.- PARALLEL UPS WIRING: TERMINAL BLOCKS****8.- OPERATION INTERFACE****9.- UPS OPERATION & CONFIGURATION****10.- STARTUP: SINGLE UPS****11.- STARTUP: PARALLEL UPS****12.- OPERATION: PARALLEL UPS****13.- ERRORS, ALARMS & TROUBLESHOOTING****14.- MAINTENANCE BYPASS MODE (MBS)****15.- EMERGENCY POWER OFF****16.- COMMUNICATION OPTIONS****17.- TECHNICAL SPECIFICATIONS****18.- SUPPORT & WARRANTY**

## 1. GENERAL SAFETY INSTRUCTIONS – SAFETY, QUALITY & PERFORMANCE STANDARDS

**WARNING:** Strictly adhere to all safety warnings and advice. It is required to read and understand this manual. Follow all instructions given in this manual for starting up and operating this product. Only qualified technician must start-up, operate and maintain this product. Keep manuals as a guide for future consults.

UPS manufacturer or distributor will never be responsible for any accident produced by lack of knowledge or negligent practices at the moment of install, starting up or maintain this product. UPS manufacturer or distributor is not liable for any damage that might rise from misusing this unit or defective installation.

### **SAFETY & USAGE:**



#### **ELECTRIC SHOCK RISK:**

This product operates with dangerous voltages. It must be installed, operated, and maintained ONLY by qualified technicians trained for this kind of products. Service personnel MUST know and understand very well all electric risks related to this product. This product is protected and sealed with screws. If you are not qualified technician do not try to install, operate, or repair this product.

**CAUTION:** Inside this equipment, due to internal batteries, there are ALWAYS dangerous voltages, EVEN the UPS is OFF and unplugged.

**CAUTION:** It must be installed following the instructions provided in this manual. The manufacturer is not responsible for personal or material damages that may arise from faulty installations or improper use.

**CAUTION:** This product has been designed to operate safely and reliably for several years. However, due to its electrical nature, the provided information should be carefully read.

**WARNING:** This product has been designed to be used indoors protected from water, direct sun light, dust, and extreme temperature. It should not be used outdoors or near sources of moisture or heat. Avoid direct sunlight.

**WARNING:** Do not put any object on the UPS; do not apply any force over UPS. Do not cover UPS ventilation.

**WARNING:** This UPS must be connected to appropriate electrical service according to selected model. Technical specs label in the UPS show the UPS power ratings. DO NOT connect this UPS to any of its own power outlets, this could damage the unit permanently.

**WARNING:** Do not connect AC motor-based equipment without a careful sizing of the UPS based on inrush current instead of average current. Inrush current typical of motor-based system could overload this UPS. UPS capacity should be sized based on peak consumption, not on average consumption.

**WARNING:** In case of emergency, power-off UPS and turn it off. Then call technical service.

### **INFORMATION FOR ENVIRONMENT PROTECTION – UPS SERVICING:**

This UPS and batteries make use of components dangerous for the environment (electronic cards, electronic components). The components removed must be taken to specialized collection and disposal centers.

### **NOTICE TO EUROPEAN UNION CUSTOMERS: DISPOSAL OF OLD APPLIANCES**



This product has been supplied from an environmentally aware manufacturer that complies with Waste Electrical and Electronic Equipment (WEEE) Directive 2002/96/CE. The “crossed-out wheeled bin” symbol at left is placed on this product to encourage you to recycle wherever possible. Please be environmentally responsible and recycle this product through your recycling facility at its end of life. Do not dispose of this product as unsorted municipal waste. Follow local municipal waste electrical and electronic equipment (WEEE).

### **TRANSPORTATION & STORAGE: WARNINGS & RECOMMENDATIONS**

**WARNING:** This equipment must be transported upright, only within its original packaging to properly protect it from shocks and impacts.

**WARNING:** This equipment should be stored upright (same as the normal operating position), in a fresh, indoors, and dry site.

**WARNING:** Before storing this equipment, its batteries should be charged for a period of at least 8 to 10 hours.

**WARNING:** During the storage period, the UPS should be periodically recharged as indicated in the Battery Care section.



**SAFETY STANDARDS / QUALITY AND PERFORMANCE**

<b>SAFETY - LOW VOLTAGE DIRECTIVE (2006/95/EC)</b> UPS Part 1-1: General & Safety UPS in accessible areas	<b>IEC/EN 62040-1</b>
<b>ELECTROMAGNETIC COMPATIBILITY - EMC DIRECTIVE (2004/108/EC)</b>	
<b>UPS, Part 2, Electromagnetic Compatibility: Radiated &amp; Conducted</b>	<b>IEC/EN 62040-2 (Cat 3)</b>
Low Freq. Conducted Disturbances & Signals:	IEC/EN 61000-2-2
Electrostatic discharge immunity Test:	IEC/EN 61000-4-2 (Level 4)
Radiated radio Frequency immunity:	IEC/EN 61000-4-3 (Level 3)
Electrical Fast Transient / burst immunity:	IEC/EN 61000-4-4 (Level 4)
Surge immunity:	IEC/EN 61000-4-5 (Level 4)
Conducted Immunity:	IEC/EN 61000-4-6 (Level 3)
Power frequency magnetic field immunity:	IEC/EN 61000-4-8 (Level 4)
<b>PERFORMANCE:</b>	<b>IEC/EN 62040-3</b>
<b>UPS Part 3: Methods of operation, specifications and test requirement</b>	
<b>IT Equipment. SAFETY. Part 1: General Requirements</b>	<b>IEC/EN 60950-1</b>
<b>BATTERY SAFETY</b>	<b>EN 50272</b>
<b>CE</b>	<b>CE compliant</b>
<b>IP PROTECTION</b>	<b>IP21 (static)</b>
<b>QUALITY MANAGEMENT:</b>	Manufactured under: <b>ISO 9001 : 2000</b>
<b>ENVIRONMENTAL MANAGEMENT:</b>	Manufactured under: <b>ISO 14001 : 2004</b>
<b>TRANSPORTATION:</b>	ETS 300019-2-2, Class 2.3

**WARNING:** Modifications made on the product or the use of this product as a part of a more complex system not expressly approved by the party responsible for compliance could void the user's authority to operate the equipment. It also could affect the product performance and the compliance of regulations. XSMART is not responsible of after-manufacturing modifications made on the product or accessories.

**WARNING:** This is a category C3 UPS product. This category includes UPS with an output current exceeding 16A and intended for use in the secondary environment. Such UPS are suitable for use in commercial or industrial installations having a minimum boundary of 30m from other buildings classified as first environment. Category C3 UPS shall meet category C3- UPS emission limits and withstand the immunity requirements of above table.

**WARNING:** This is a product for commercial and industrial applications in the secondary environment. Installation restrictions or additional measures may be needed to prevent disturbances.

**DEFINITIONS:**

**Primary Environments:** Those sites directly connected without intermediate transformers to the public low-voltage mains supply, like residential buildings and small companies without their own transformer.

**Secondary Environments:** Those sites not connected directly to public low-voltage mains that supplies residential buildings like industries and big companies powered by its own intermediate transformer.

## 2.- PRODUCT DESCRIPTION & AVAILABLE MODELS

### UPS DESCRIPTION

This is an **ONLINE UPS (Uninterruptible Power Supply), with single-phase input and output**. Classification according to "Classification of UPS by Performance", (EN-62040-3):

**V F I - S S - 1 1 1**

- V F I (Output dependency):** Stands for Voltage and Frequency Independent (from those of the input) unit.  
**S S (Output Waveform):** Stands for Sinusoidal Output either in normal mode or battery mode.  
**1 1 1 (Output Dynamic Performance):** Stands for Output Dynamic Performance Classification "1". in either:  
1: Change of operation mode - 1: Step linear load - 1: Step reference non-linear load.

### FEATURES

- Online Technology with IGBT components in inverter and rectifier stages, with PWM modulation.
- Dual input: Main UPS input and auxiliary input (bypass line).
- Includes Conformal Coating treatment in cards and internal parts. Conformal coating is a protection against moisture and corrosive contaminants, that assure a stable performance and enhances span life in diverse environments, as long as technical specifications requirements are fulfilled.
- Versatile and powerful touchscreen with access icons to the setup and operation menus.
- Spike suppression circuits based on MOV technology.
- Electromagnetic Interference (EMI) filtering system.
- 100% compatible with power generators.

### MODELOS DISPONIBLES:

#### **For 400/230V: OPTIMA-33-T10 10K / 20K / 30K / 40K / 60K-NB / 80K-NB**

3-Phase Input 3-Phase Output UPS. Electronic design to work in 400/230V systems without transformers. Available models:

- 10K-400: 10KVA/10KW Single cabinet, with electronic and internal batteries.
- 20K-400: 20KVA/20KW Single cabinet, with electronic and internal batteries.
- 30K-400: 30KVA/30KW Single cabinet, with electronic and internal batteries.
- 40K-400: 40KVA/40KW Single cabinet, with electronic and internal batteries.
- 60K-400: 60KVA/60KW Cabinet with electronic without batteries. External Batteries Required.
- 80K-400: 80KVA/80KW Cabinet with electronic without batteries. External Batteries Required.

#### **For 480/277V: OPTIMA-33-T10 10K-NB / 20K-NB / 30K-NB / 40K-NB / 60K-NB-NB / 80K-NB**

3-Phase Input 3-Phase Output UPS for 400/230V (380/220V) systems. Available models:

- 10K-480: 10KVA/10KW Cabinet with electronic without batteries. External Batteries Required.
- 20K-480: 20KVA/20KW Cabinet with electronic without batteries. External Batteries Required.
- 30K-480: 30KVA/30KW Cabinet with electronic without batteries. External Batteries Required.
- 40K-480: 40KVA/40KW Cabinet with electronic without batteries. External Batteries Required.
- 60K-480: 60KVA/60KW Cabinet with electronic without batteries. External Batteries Required.
- 80K-480: 80KVA/80KW Cabinet with electronic without batteries. External Batteries Required.

#### **For 208/120V: OPTIMA-33-T10 10K / 20K / 30K-NB / 40K-NB**

3-Phase Input 3-Phase Output UPS. Electronic design to work in 208/120V systems without transformers. Available models:

- 10K-208: 10KVA/10KW Single cabinet, with electronic and internal batteries.
- 20K-208: 20KVA/20KW Single cabinet, with electronic and internal batteries.
- 30K-208: 30KVA/30KW Cabinet with electronic without batteries. External Batteries Required.
- 40K-208: 40KVA/40KW Cabinet with electronic without batteries. External Batteries Required.

**BATTERIES: CARE AND MAINTENANCE**

- Only top-quality batteries are used in our equipment.
- Batteries, in general (regardless of their technology), are components that lose capacity over time and with use.
- The batteries lifespan in our ONLINE UPS is 4 to 5 years, considering environmental temperatures below 25°C and optimal working conditions. Lifespan can decrease significantly with rising temperatures and unfavorable working conditions.
- Batteries lifespan can also be affected by other operational conditions, such as the quality of the electrical service and the quantity and type of equipment connected to the UPS.
- Batteries should be periodically checked to verify their capacity and ensure proper autonomy.

- **FOR A LONGER BATTERY LIFE, IT IS RECOMMENDED TO PERFORM A DEEP DISCHARGE EVERY 2 OR 3 MONTHS.**
- **IF UPS IS STORED FOR LONG TIME, RECHARGE BATTERIES ACCORDING TO NEXT TABLE:**

Storage Temperature	Recharge Frequency	Recharge Duration
-25°C to +30°C	Every 4 months	6 hours
+30°C to +45°C	Every 2 months	6 hours

**XBAT: EXTERNAL BATTERY PACK**

OPT33-T10 UPS family features several models of external battery cabinets to complete units without internal batteries, as well as extend the standard backup times for models with internal batteries.

**Available Models:****XBAT-OPT33-120V-40P: +/- 120VDC**

Cabinet with 40 batteries (2 parallel groups of 20 batteries each): +/- 120VDC

Compatible with following models:

- OPT33-T10-10K / 20K / 30K / 40K (208/120V)
- OPT33-T10-10K (400/230V)
- OPT33-T10-10K (480/277V)

**XBAT-OPT33-120V-80P: +/- 120VDC**

Cabinet with 80 batteries (4 parallel groups of 20 batteries each): +/- 120VDC

Compatible with following models:

- OPT33-T10-10K / 20K / 30K / 40K (208/120V)
- OPT33-T10-10K (400/230V)
- OPT33-T10-10K (480/277V)

**XBAT-OPT33-240V-40P: +/- 240VDC**

Cabinet with 40 batteries (1 group of 40 batteries): +/- 240VDC

Compatible with following models:

- OPT33-T10-20K / 30K / 40K / 60K / 80K (400/230V)
- OPT33-T10-20K / 30K / 40K / 60K / 80K (480/277V)

**XBAT-OPT33-240V-80P: +/- 240VDC**

Cabinet with 80 batteries (2 parallel groups of 40 batteries each): +/- 240VDC

Compatible with following models:

- OPT33-T10-20K / 30K / 40K / 60K / 80K (400/230V)
- OPT33-T10-20K / 30K / 40K / 60K / 80K (480/277V)

**WARNING**

**External battery packs (XBAT) for OPT33-T10 models, might NOT be compatible with other OPTIMA UPS models. To avoid damages, make sure to connect XBAT with DC voltages compatible with your UPS.**

**PARTS ID, REAR PANEL & TERMINAL BLOCKS**

**MODELS: 400/230V & 480/277V - 10K/20K/30K/40K**

- |  |                                    |
|--|------------------------------------|
| 1.- RS232 Port                               | 8.- AC Input Breaker               |
| 2.- USB Port                                 | 9.- MBS (Maintenance Bypass Switc  |
| 3.- EPO (Emergency Power Off)                | 10.- AC Terminal block (In/Out)    |
| 4.- Share Current (for parallel UPS)         | 11.- Output Switch                 |
| 5.- Parallel Control Port (for parallel UPS) | 15.- Bypass Input Breaker (Bypass) |
| 6.- Smart port                               | 20. MBS Safety Cover               |
| 7.- XBAT DC Connection                       |                                    |

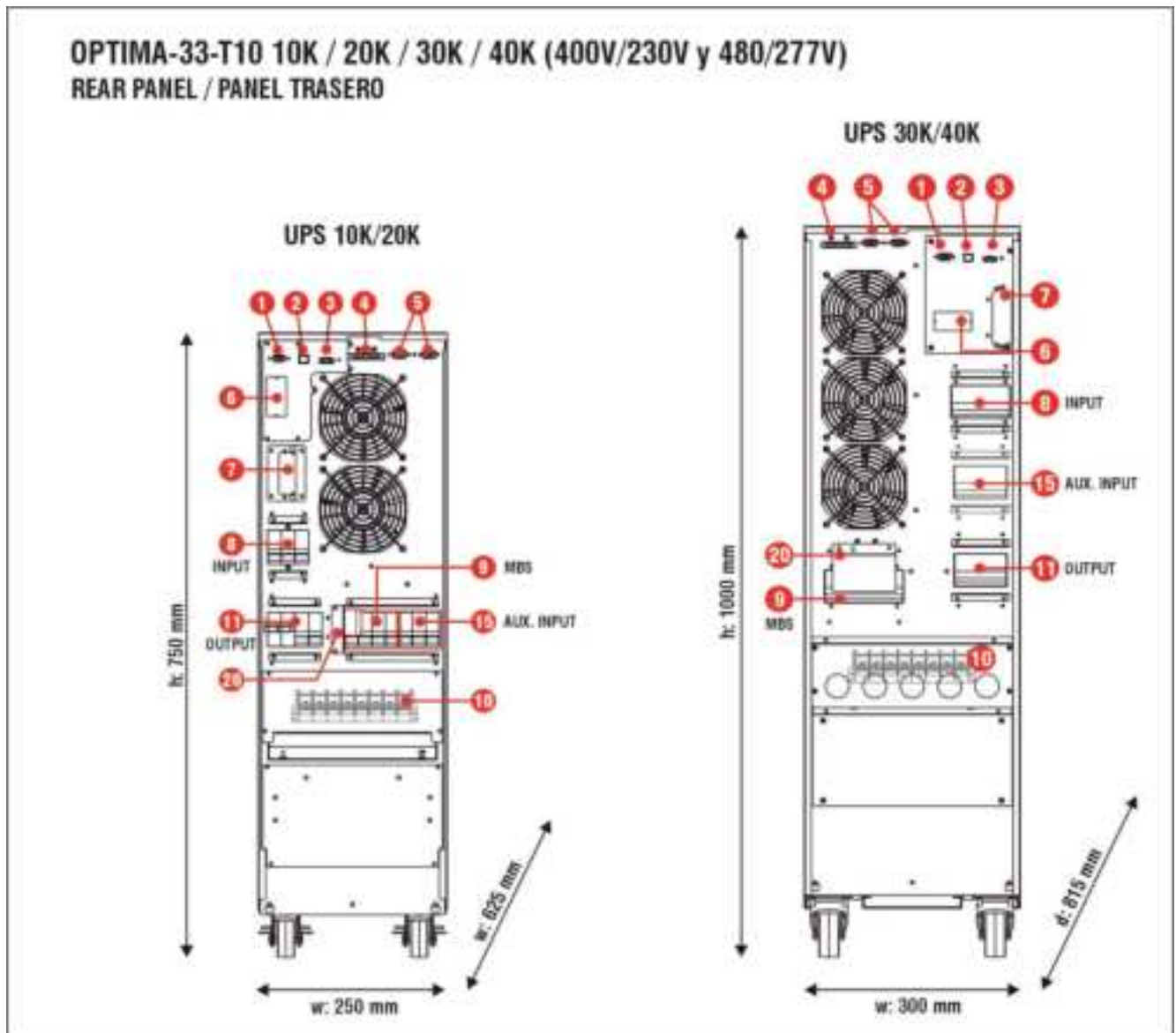

**MODELS: 400/230V & 480/277V - 60K/80K**

- |  |                                       |
|--|---------------------------------------|
| 1.- RS232 Port                               | 8.- AC Main Input Breaker             |
| 2.- USB Port                                 | 9.- MBS (Maintenance Bypass Switch)   |
| 3.- EPO (Emergency Power Off)                | 10.- AC & Bypass Input Terminal block |
| 4.- Share Current (for parallel UPS)         | 11.- Output Switch                    |
| 5.- Parallel Control Port (for parallel UPS) | 12.- Output Terminal Block            |
| 6.- Smart port                               | 15.- Bypass Input Breaker             |
| 7.- XBAT DC Terminal Block                   | 20. MBS Safety Cover                  |

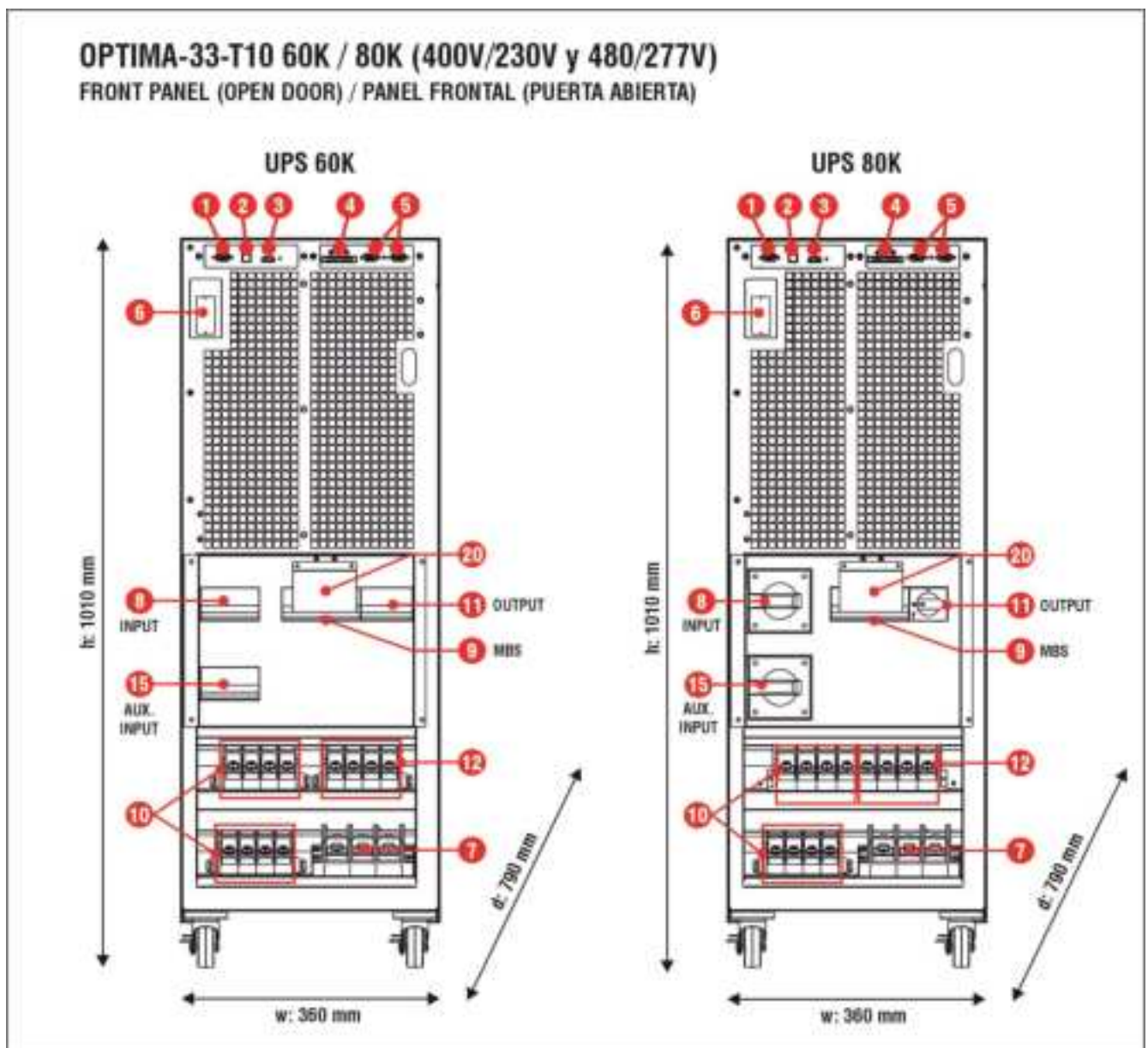

**MODELS (208/120V) – 10K/20K**

- |  |                                       |
|--|---------------------------------------|
| 1.- RS232 Port                               | 8.- AC Input Breaker                  |
| 2.- USB Port                                 | 9.- MBS (Maintenance Bypass Switch)   |
| 3.- EPO (Emergency Power Off)                | 10.- AC Input & Output Terminal block |
| 4.- Share Current (for parallel UPS)         | 11.- Output Switch                    |
| 5.- Parallel Control Port (for parallel UPS) | 15.- Bypass Input Breaker             |
| 6.- Smart port                               | 20. MBS Safety Cover                  |
| 7.- XBAT DC Connection                       |                                       |

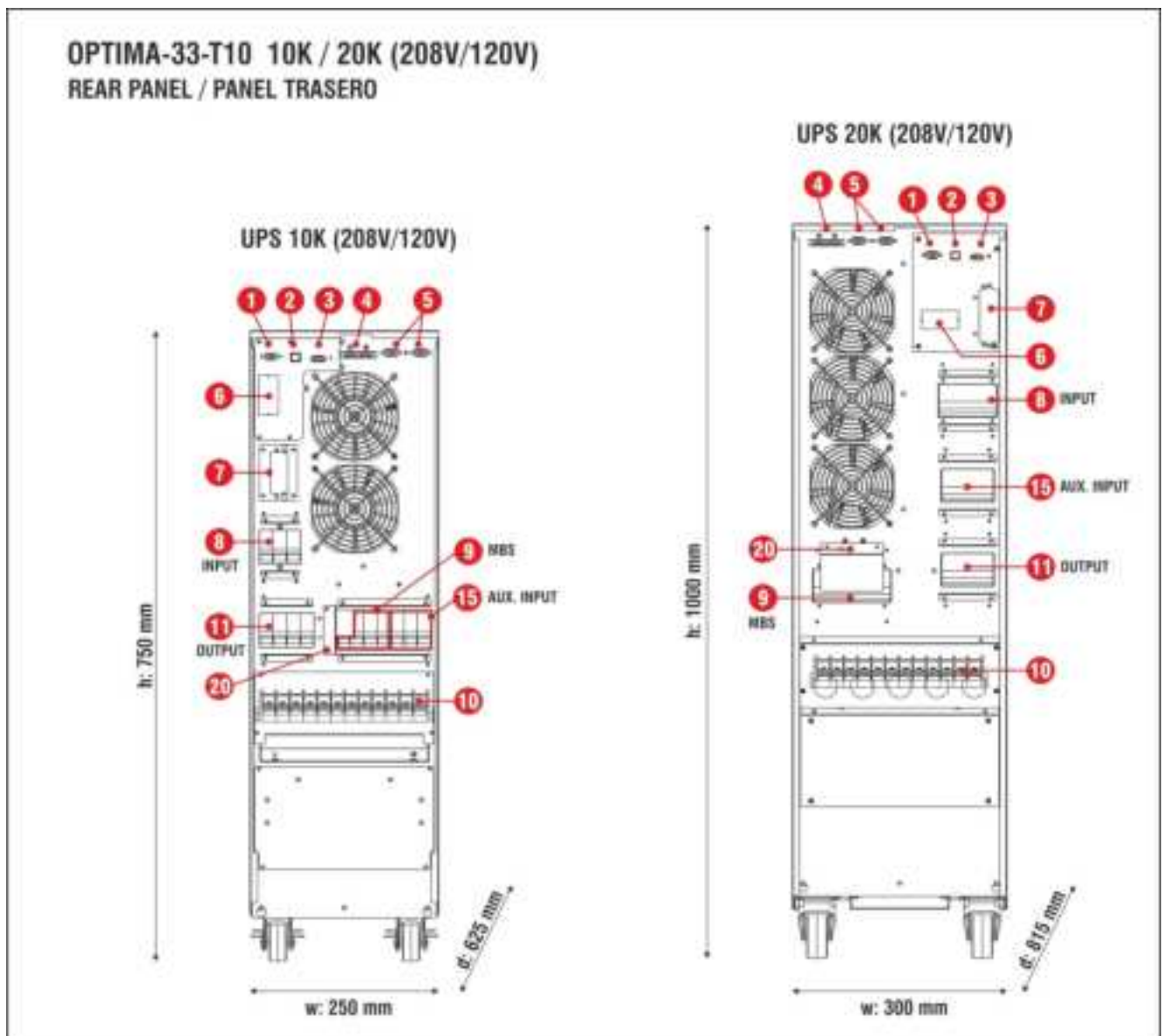

**MODELS 208/120V – 30K/40K**

- |  |                                       |
|--|---------------------------------------|
| 1.- RS232 Port                               | 8.- AC Main Input Breaker             |
| 2.- USB Port                                 | 9.- MBS (Maintenance Bypass Switch)   |
| 3.- EPO (Emergency Power Off)                | 10.- AC Input & Bypass Terminal block |
| 4.- Share Current (for parallel UPS)         | 11.- Output Switch                    |
| 5.- Parallel Control Port (for parallel UPS) | 12.- Output Terminal Block            |
| 6.- Smart port                               | 15.- Bypass Input Breaker             |
| 7.- XBAT DC Terminal Block                   | 20. MBS Safety Cover                  |

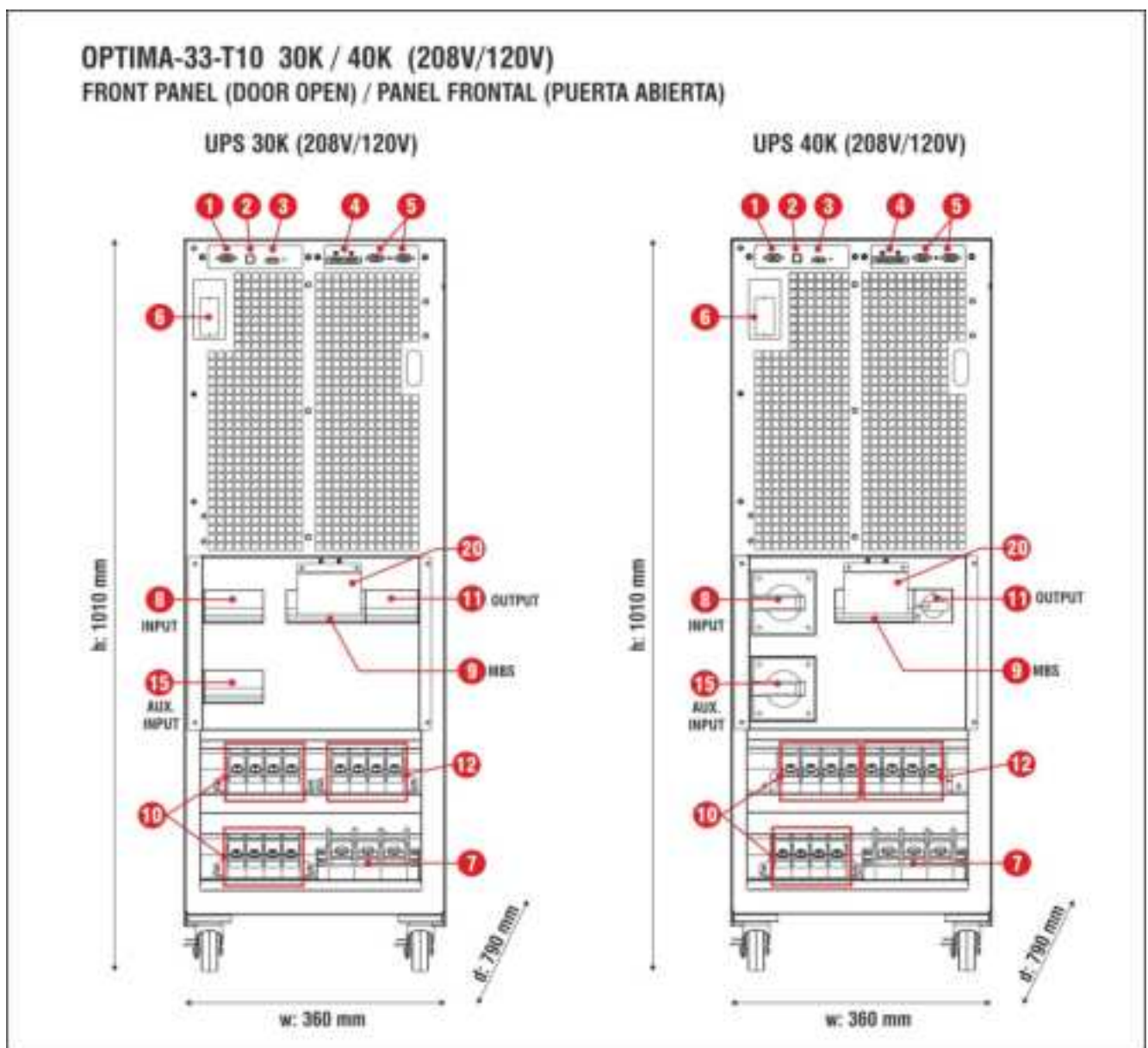

**3.- INTERNAL BLOCKS DIAGRAM**

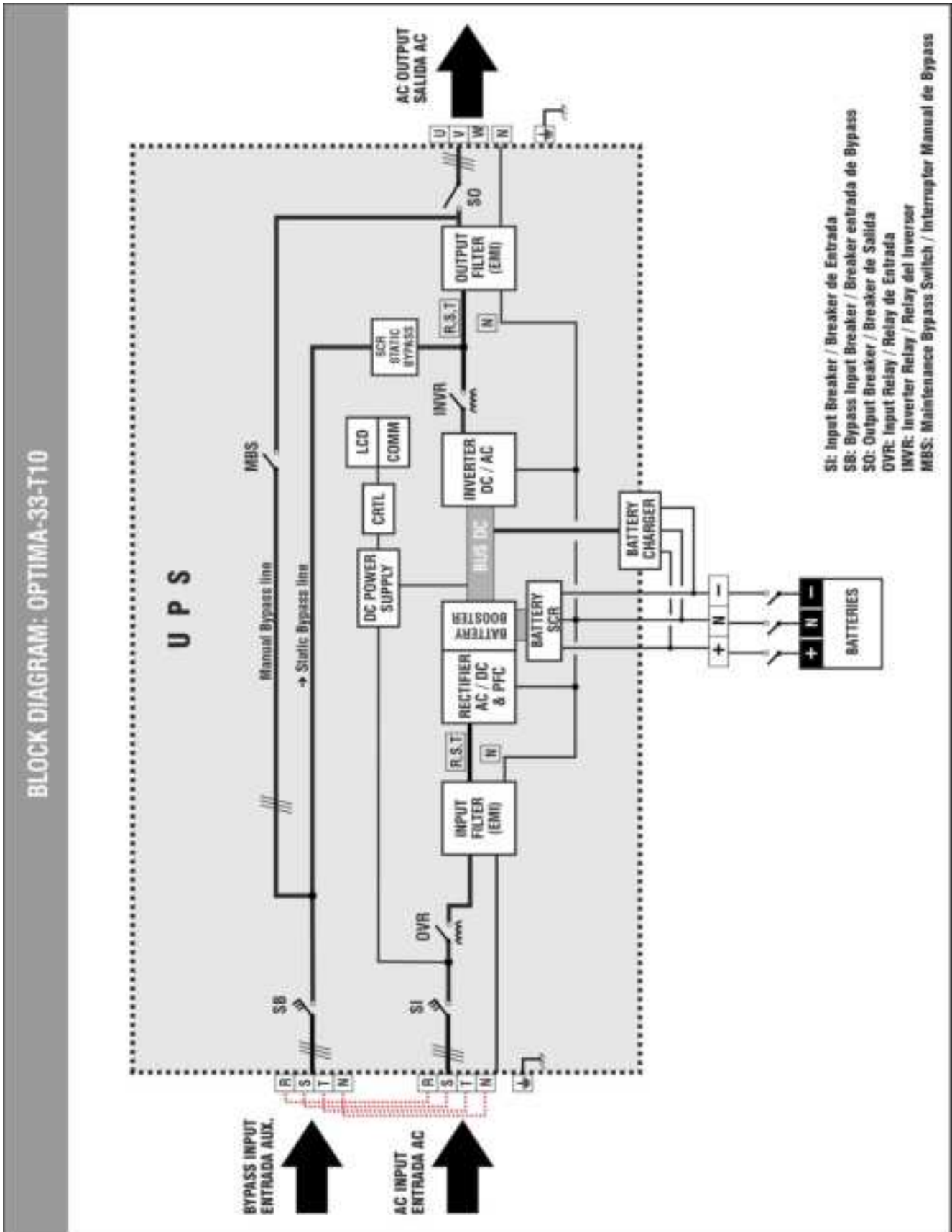

## 4.- PRINCIPLES AND OPERATION MODES

This is an ONLINE Double Conversion UPS, and it is designed to deliver clean, seamless, and highest-quality power, protecting your computer equipment and your valuable information. Waveform delivered by this UPS is pure sinewave, just like the main electrical service. Depending on the state of the incoming power service and its configuration, the UPS can assume different operation modes as described in this section.

This UPS can operate individually or, up to 3 units installed as a parallel system, as explained below:

### SINGLE AND PARALLEL OPERATION

This UPS can operate in single mode or connected in parallel, up to a maximum of 3 units. In single mode, there is only one UPS responsible for generating the entire output power.

In parallel operating mode, up to 3 units can be connected in parallel, sharing the input power and the responsibility of generating the output power. AC INPUT is connected in parallel to all UPS units, and the AC OUTPUTS of the UPS are also wired in parallel.

This parallel operating scheme allows for 2 important advantages:

- \* **Progressive Growth:** The UPS system can grow in power by adding UPS units in parallel.

- \* **Increased Reliability:** In the event of a failure of one of the UPS units, the rest of the UPS can maintain the system operating.

In parallel systems, all UPS must be of the same model and capacity. Firmware must be also compatible to operate in parallel. For more information, consult the section on installation and operation of parallel UPS in this manual.

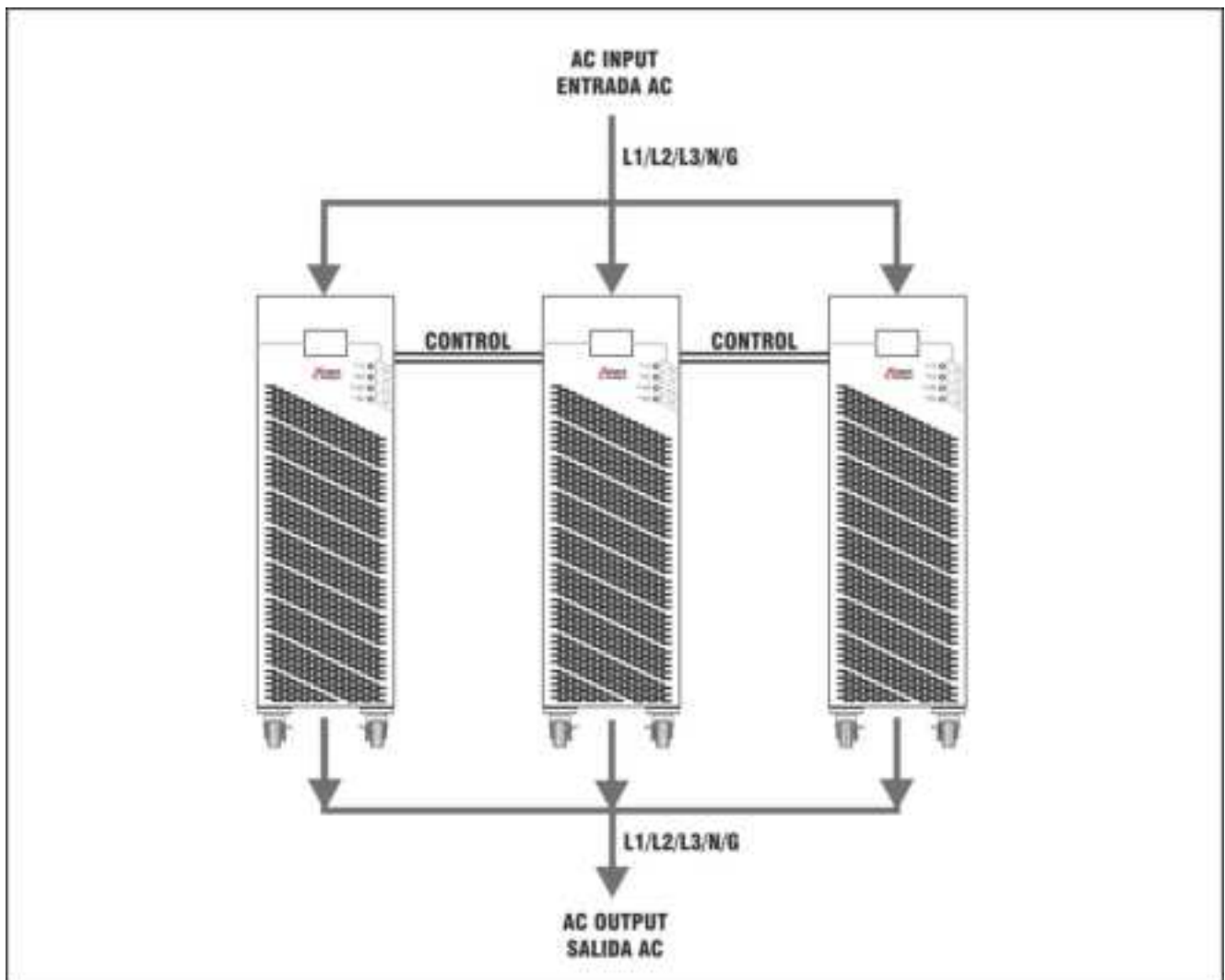

## **OPERATION MODES**

### **ONLINE Mode (Known as NORMAL Mode or AC Mode)**

If AC input is within the acceptable configured range and UPS is started through the energizing and power-on procedure, it will enter ONLINE mode. In this mode, UPS powers its output from its own inverter.

### **BATTERY Mode (INVERTER Mode)**

While in ONLINE mode, if UPS detects that AC input has gone out of acceptable voltage or frequency range, UPS switches to BATTERY mode, draining power from batteries to power its output. There are no transitions or micro-outages in UPS output during transfer from ONLINE Mode to BATTERY Mode. We can assure a ZERO (0 ms) transfer time. UPS can operate in this mode as long as the power stored in the batteries is consumed.

### **ECO Mode (Power Saving)**

This UPS offers a power-saving feature called ECO mode, to increase the UPS power efficiency by reducing losses in the inverter stage. This mode is disabled by default and must be enabled through the UPS's configuration menu if required. It is recommended NOT to activate ECO mode unless the advantages and disadvantages of this mode are understood. In this mode, UPS powers its output with the AC input energy, directly through the internal bypass line, while keeping its inverter off. UPS remains in ECO mode as long as the input voltage and frequency stay within the acceptable range configured for this mode (ECO mode range). Transition between ECO mode and ONLINE or BATTERY modes takes about 4ms, typically. This mode is incompatible with parallel operation of the UPS units. If the installation is done in parallel, do not attempt to activate ECO mode in any of the units.

### **BYPASS Mode**

UPS comes factory-configured with the BYPASS function enabled. This allows UPS to power its outputs directly from BYPASS input through the internal bypass line as soon as it is energized and completes its self-diagnostics.

UPS remains in BYPASS mode until it is turned on using the standard procedure, then it enters ONLINE mode. BYPASS mode can be disabled through the configuration menu. If BYPASS mode is disabled, the UPS will enter STAND-BY mode when required.

BYPASS mode is maintained while input voltage and frequency remain within the range configured for BYPASS mode. If UPS has BYPASS function enabled, BYPASS mode will be activated under the following conditions:

- When UPS is energized without being turned on using the standard procedure.
- When UPS experiences an overload on its output, it will automatically switch to BYPASS to protect the inverter.
- When maintenance switch cover MBS located on the rear panel of the UPS is removed (tower models only).
- When UPS detects an internal problem, it enters BYPASS mode to keep its output powered from the input.

### **STANDBY Mode**

When BYPASS mode is not allowed, and UPS needs to go to BYPASS, the unit will be forced to enter STANDBY mode, in which it will turn off its outputs and keep the screen illuminated, waiting for operator action. This STANDBY mode would also be activated when energizing the UPS with BYPASS mode disabled.

### **Conversion of Frequency Mode (CVCF) (not available in some models)**

This UPS offers a sophisticated function that allows setting the output frequency value, even if it is different from the input frequency. For example, a UPS operating in a 60Hz system can generate its output at 50Hz or vice versa.

This function is configured through the configuration menu available on the LCD panel. Refer to the configuration section for details.

### **IMPORTANT:**

1.- CVCF (frequency conversion) function is incompatible with the BYPASS mode, so when frequency conversion function is activated, UPS is not allowed to switch to BYPASS mode when bypass is required. The reason is that if a UPS is supplied with a 50Hz signal and is configured to generate its output at 60Hz, it is implicitly being told that the only acceptable output is one supplied at 60Hz. If BYPASS mode were activated, the 50Hz input would be connected to the output, providing a frequency different from what is configured in the CVCF function. Under these circumstances, if BYPASS mode is forced, the UPS will turn off its outputs.

2.- When the CVCF function is activated, the maximum power that the UPS can deliver decreases by 40% of its nominal maximum power. For example, for a 30KVA UPS, the maximum output power drops to 18KVA.

### **WARNING Mode**

Under certain abnormal circumstances, UPS displays a warning message on screen and activates an intermittent audible alarm. UPS typically remains in online mode in the presence of alarms.

### **FAULT Mode**

If a significant problem is detected within or outside the UPS, it enters error mode, displaying an error message on the screen and activating a continuous audible alarm. The UPS typically switches to BYPASS mode.

**SCREENS ACCORDING TO OPERATION MODE**

The UPS will alternately display different screens with the following information:

**OPERATION MODES**

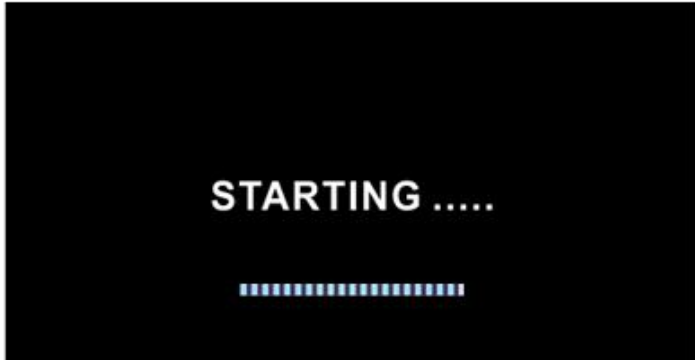
<b>POWER-ON</b>	<b>Description</b>	With UPS properly installed and powered, its screen lights up and indicates that it is performing self-diagnosis for a brief period until it adopts its valid operating mode.
	<b>Screen</b>	

<b>BYPASS</b>	<b>Description</b>	Once UPS has initialized, it will switch to BYPASS mode, waiting to be started. BYPASS mode is automatically adopted when UPS detects an abnormal condition that prevents it from operating in ONLINE mode. This BYPASS mode is also adopted when UPS is turned off by the operator.
	<b>Screen</b>	

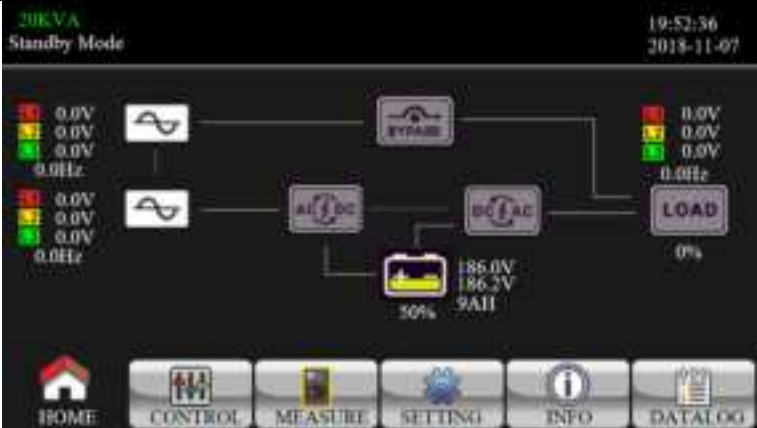
<p><b>STANDBY</b> (Powered, bypass disabled &amp; output turned-off)</p>	<p><b>Description</b></p>	<p>When BYPASS mode is disabled, and conditions to go to BYPASS mode occur, UPS is forced to adopt STANDBY mode, which involves turning off outputs and waiting to return to ONLINE mode.</p>
	<p><b>Screen</b></p>	

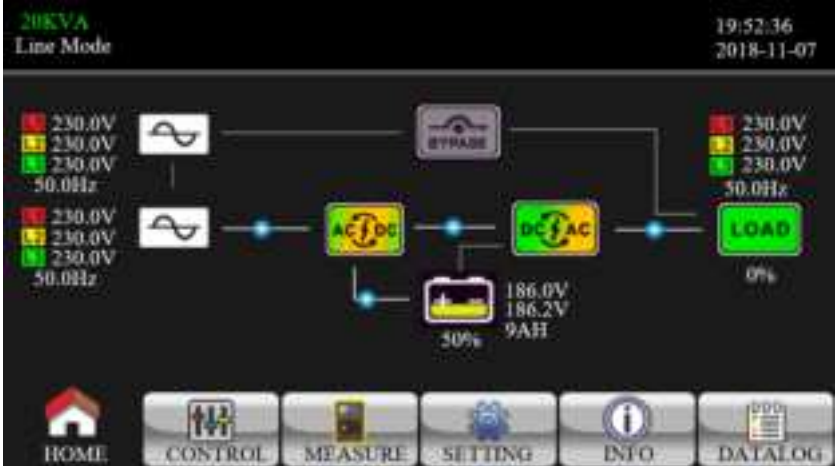
<p><b>ONLINE</b> (AC MODE)</p>	<p><b>Description</b></p>	<p>When UPS has been started (procedure will be explained later) and input is within valid range, UPS enters ONLINE mode. The screen displays all voltage information (Input, Output, and Batteries), frequencies (Input and Output), Load, System Date, and Time.</p>
	<p><b>Screen</b></p>	

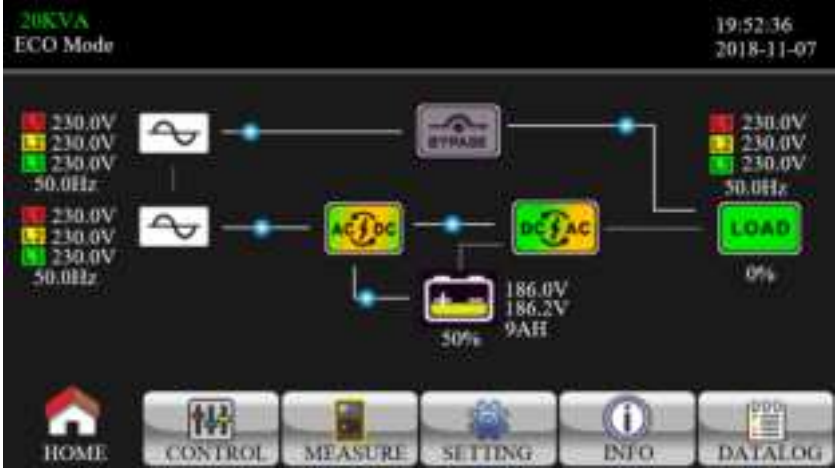
<p><b>ECO</b> <b>(POWER SAVINGS)</b></p>	<p><b>Description</b></p>	<p>When ECO mode is activated, UPS will operate in this mode if the input is within an acceptable range. Values displayed on screen are like those in ONLINE mode.</p>
	<p><b>Screen</b></p>	

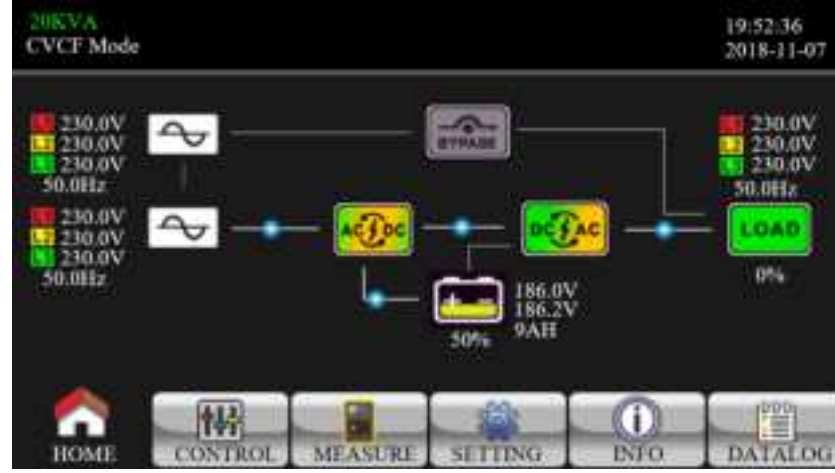
<p><b>CVCF</b> <b>(FREQUENCY CONVERSION)</b></p>	<p><b>Description</b></p>	<p>When Frequency Converter mode is active, inverter will generate a constant frequency of 50Hz or 60Hz (depending on the configuration). In this mode, BYPASS mode is disabled.</p>
	<p><b>Screen</b></p>	

<b>BATTERY MODE</b>	<b>Description</b>	When UPS is in ONLINE mode and input goes out of the acceptable range, UPS automatically switches to BATTERY mode.
	<b>Screen</b>	

<b>BATTERY TEST</b>	<b>Description</b>	In this mode, the UPS performs a battery test. This mode can be started by the operator through the <b>BATT TEST</b> command in <b>CONTROL</b> menu.
	<b>Screen</b>	

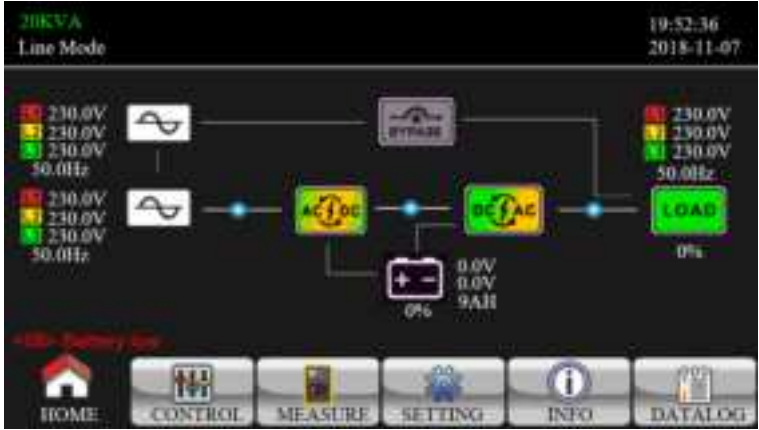
<p><b>WARNING</b></p>	<p><b>Description</b></p>	<p>If a non-critical abnormal condition occurs that allows the UPS to continue operating in ONLINE mode, the UPS will display the code and description of the problem intermittently on the screen and emit an intermittent audible signal. The Alarm table lists the codes and their meanings. These situations are recorded in the UPS's Data Log. The audible signal can be muted (see section 9. UPS OPERATION &amp; CONFIGURATION, for more details), in some cases, it may not be possible until the cause of the alarm has been resolved.</p>
	<p><b>Screen</b></p>	

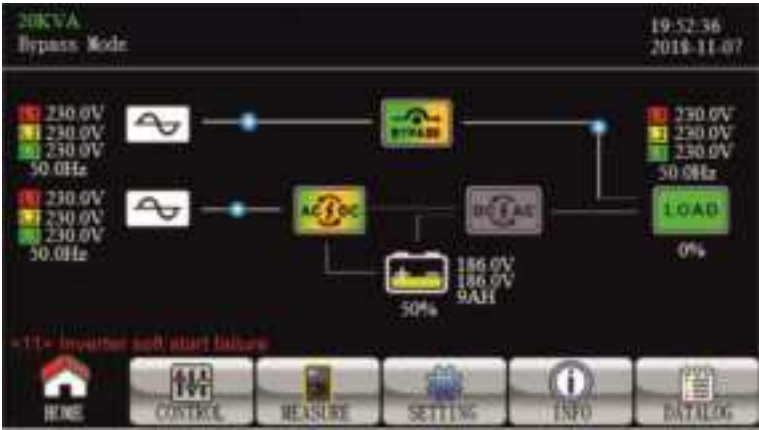
<p><b>FAULT</b></p>	<p><b>Description</b></p>	<p>When a CRITICAL condition is detected that prevents the UPS from operating in ONLINE mode, UPS automatically switches to BYPASS mode and displays one or more Fault codes on screen continuously while emitting a continuous sound signal. Fault table lists the codes and their meanings. These situations are recorded in the UPS's Data Log.</p>
	<p><b>Screen</b></p>	

## 5.- INSTALLATION: SITE CONDITIONS REVISION

### SAFETY INSTRUCTIONS



**WARNING:** Before reading this section, you must read and understand very well section 1 of this manual: “GENERAL SAFETY INSTRUCTIONS”.

### WARNINGS, RECOMMENDATIONS AND LIABILITY LIMITATION

**REACH AND LIABILITY LIMITATION:** The preparation of the site, wiring and all protection devices must be supplied by end user, and it will not be responsibility neither the UPS distributor nor the UPS technician in charge of the start-up.

The site will be conditioned by end user or electrical contractor and must fulfill with local normative and directives and UPS technical requirements.

This manual describes minimal conditions and technical requirements with which the site must accomplish.

Directives and requirements described in this manual, do not pretend to substitute in any way local electrical directives or normative.

In some cases, local directives or regulations might be more exigent than UPS technical requirements described by this manual. In that case end user electrical contractor must be sure to comply with all related local electrical regulations and directives.

**WARNING:** Power lines must be protected by protection devices against over current (breakers) or leak currents with capacity and technology appropriate to effectively accomplish its function. Moreover, installation grounding must be correct.

**WARNING:** It is mandatory to connect the cabinet of this equipment and its accessory cabinets (batteries, transformers, etc.) to a grounding system suitable for this purpose and for the equipment capacity. Ground connection must be the first to be made, before connecting the rest of the wiring.

**WARNING:** Install the UPS in well-ventilated locations and leave room enough between UPS and close objects and structures.

**WARNING:** Do not connect to UPS equipment or devices that exceed its capacity, this would overload the UPS.

**WARNING:** This product has been designed to be used in indoor environments protected from water, sunlight, dust, and extreme temperatures. It should not be used outdoors or near sources of moisture or heat. Avoid direct sunlight. We recommend controlled environment with temperature between 20 °C and 25 °C.

**WARNING:** Do not put any object on the UPS; do not apply any force over UPS. Do not cover UPS ventilation.

**ADVERTENCIA:** This UPS must be connected to appropriate electrical service according to selected model. Technical specs sticker in the UPS shows the UPS power ratings. DO NOT connect this UPS to any of its own power outlets, this could damage the unit permanently.

**WARNING:** DO NOT connect AC motor-based equipment without a careful sizing of the UPS based on inrush current instead of average current. Inrush current typical of motor-based system could overload this UPS.

**WARNING:** This unit MUST NOT be installed into closed boxes/cabinets that avoid fresh air access. During normal operation, this unit needs fresh air to flow through ventilation system (Vents) to cool power circuits. Installing this unit in a closed box/cabinet makes inner air to be recycled without refreshing, increasing inside temperature, exceeding operation max. temperature, and causing permanent damage to the UPS.

**WARNING:** WARNING sign must be placed on the main panel to alert maintenance personnel of the presence of a UPS connected to that electrical panel. The UPS could induce dangerous voltages in the electrical panel, even though the main switches are open (OFF).

Warning sign Example:

**VOLTAGE BACKFEED RISK**  
UPS CONNECTED TO THIS CIRCUIT  
Before working on this circuit:

- \* Isolate UPS
- \* Check for dangerous voltage in all circuit terminals.



## **SITE INSPECTION AND INSTALLATION CONDITIONS**

---

### **REGULATIONS AND LEGAL DIRECTIVES**

It is necessary to check that installation site, wiring and power protection in the installation supplied by end user, fulfill technical parameters required by UPS.

A particular installation might accomplish with UPS requirements but not with local directives and regulations.

The end user and/or electrical contractor will be responsible of watching for complying with electrical regulations and normative during electrical installation managed by end user.

Inspection performed by installation technician is not intended to confirm regulations and directives accomplishing but only with technical needs for optimal UPS operation.

### **SITE INSPECTION**

- During transport of this UPS from a cold place to a warmer and more humid one, some condensation could be generated. Leave the UPS for at least 2 hours to climate to new installation site.
- Do not install the UPS outdoors or near water sources nor in wet environment.
- Do not install the UPS in sites exposed to sun light or heat sources. Temperature at operation site should never rise over 35 °C. Batteries' life shortens over 25 °C.
- Installation site must be dry, fresh, free of dust, fibers, and any other objects (conductors or not) suspended in the air that could get into the UPS thru the ventilation system (Fan).
- Do not block UPS ventilations.

## **UPS INPUT AND OUTPUT POWER LINES PROTECTION**

---

### **AC LINES PROTECTIONS DEVICES:**

All UPS Inputs and outputs must be protected by circuit breakers and current leak protections. Protection capacity and type must fulfill local regulations as well as directives from this manual. Grounding must be according to local directives as well.

### **DC LINES PROTECCION (EXTERNAS BATTERIES CONNECTION):**

To install external batteries, it is mandatory to install breaker on DC lines connecting UPS with each External Battery Module. Some UPS and Battery Packs include this protection on their Back Plane. If not, the user or the installation responsible must install this protection which must comply with technical specifications required in this manual.

## **ELECTRICAL DEVICES AND MATERIAL REVISION**

**WARNING:** Before starting the installation, confirm that the electrical lines involved in the installation have their electrical circuits open and there are no hazardous voltages in them. switch or switches associated with involved electrical lines must be set to "OFF" position before starting the UPS installation. After disconnecting power from the lines involved, confirm with a digital voltmeter that there are no hazardous voltages in them.

**IMPORTANT:** We strongly recommend placing a warning sign on main electrical board (where protections are located) to avoid external personnel manipulating AC lines during revision and start-up work is performed.

**UPS INSTALLATION****UNPACKING AND HANDLING**

- 1- This equipment comes packed on a pallet and is protected with wood and cardboards. Cut the straps and carefully remove the packaging.
- 2- Unpack the equipment according to the following figure.
- 3- It is recommended to disable the levelers by turning them counterclockwise so that the equipment can roll (as per step 5).
- 4- Remove the fixing angles to the pallet shown in step 6. According to the model, there can be 4 angles, 2 on each side or a larger support on each side.

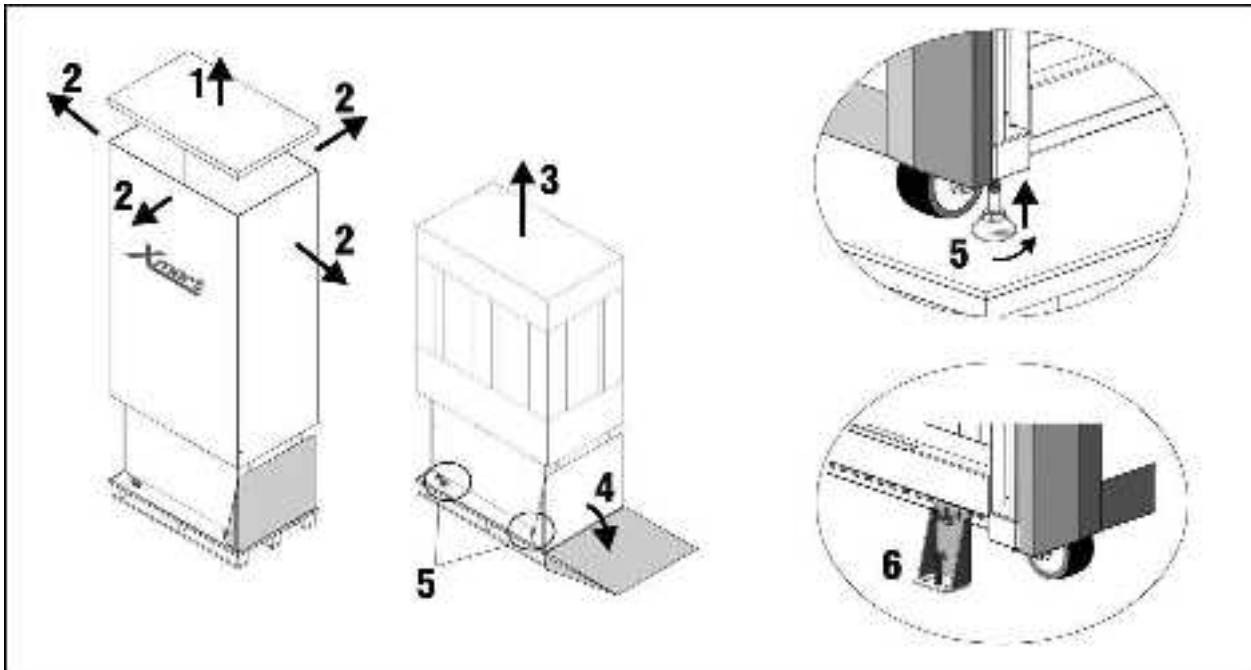

5- According to the model, it could be too heavy to be handled by a single person. We suggest using a forklift device to help lower the equipment from the pallet or the involvement of 3 or 4 people to roll it down the ramp that comes with the equipment's packaging.

6- The UPS is supplied with wheels that can ease movement over short distances once it has been unpacked. **Wheels only allow forward and backward movements, never lateral movements.**

Once located in its final place, the levelers must be adjusted to prevent the equipment from rolling and to ensure it is leveled.

**FLOOR ANCHORING:** The angles identified in step 6 of the above figure can be used for this purpose.

**LOCATION**

- This product is designed to be used in indoor environments protected from water, sun, dust, and extreme temperatures. See the safety instructions at the beginning of this section and operating conditions in the specifications table.
- Maintain distances shown in the following image to allow good ventilation and enable proper servicing of the equipment.
- After placing the cabinets in their location, it is recommended to engage the brakes on their wheels to prevent accidental movement.

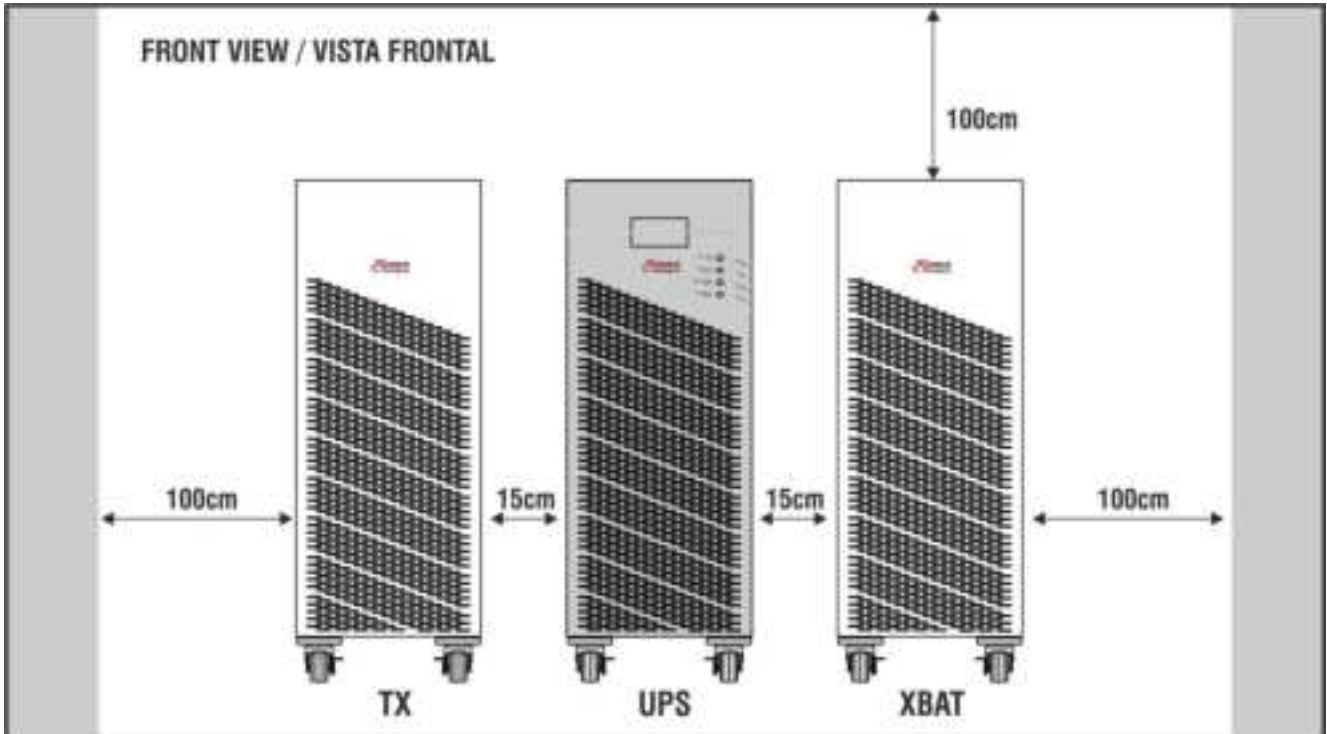

- TX:** External Transformers Cabinet, if needed.  
**UPS:** UPS Electronic Cabinet. 480/277V models also include internal transformers.  
**XBAT:** External Batteries Cabinet, if needed.

**PARALLEL UPS**

- For UPS parallel installation, it is recommended to leave 100cm between the UPS to ease future maintenance tasks. The distance between the external battery cabinets and their respective UPS can be smaller.
- After placing the cabinets in their location, it is recommended to engage the brakes on their wheels to prevent accidental movement.
- See next image for Reference.

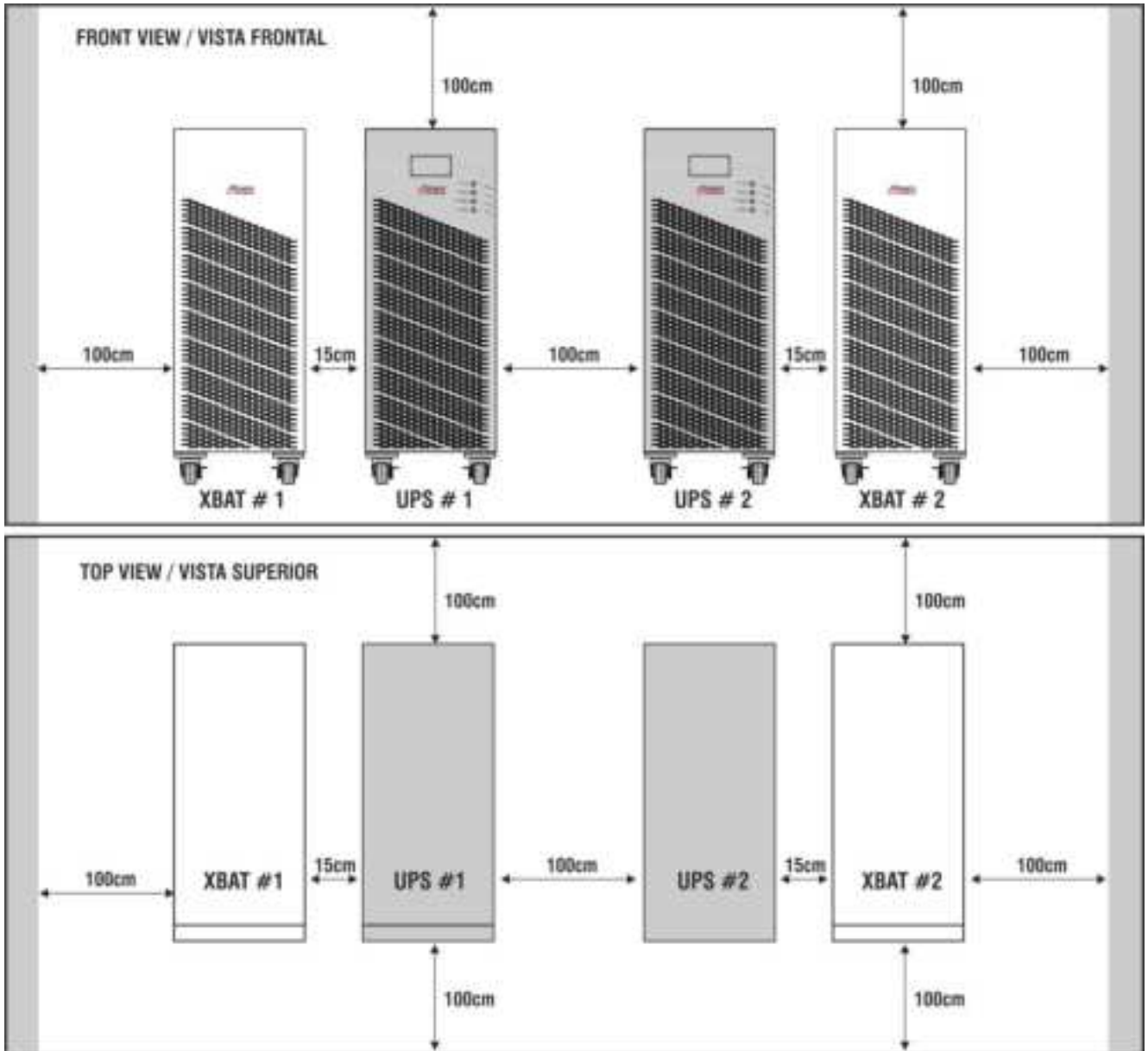

## ELECTRICAL REQUIREMENTS

ALL power lines (input and output) of this UPS must be protected by protection devices (Breaker) against overcurrent and earth-leakage. With the capacity and appropriate technology to effectively fulfill its function. Moreover, the site must offer an appropriate EARTHING system.

- This UPS must be connected to appropriate electrical service according to selected model. Technical specs label in the UPS show the UPS power ratings. DO NOT connect this UPS to any of its own power outlets, this could damage the unit permanently.
- Do not connect neither equipment nor devices that exceed Max. UPS capacity.
- Connect to this UPS ONLY computer related equipment. DO NOT connect neither medical nor critical availability equipment. DO NOT connect Alternate Current Motor-based equipment. DO NOT connect Also, do not connect appliances such as ovens, vacuum cleaners, refrigerators, etc.

## EARTH LEAKAGE PROTECTION

In many countries today, legal regulations require the installation of Earth leakage protection in AC lines to protect users in case of a discharge or ground fault. It will be the responsibility of the end user or user's electrical contractor to include and select these devices in the UPS power circuit.

## EN-IEC 62040-1

If regulations of the country of installation require compliance with safety standard EN-IEC 62040-1, the installation of an external automatic system (not included with the UPS) preventing the possibility of voltage return on the AC INPUT line, coming from the UPS's internal bypass line, as indicated below, will be needed.

Under normal conditions, the proper functioning of the UPS prevents this type of power return, but there could be a case where a failure in the "STATIC BYPASS SWITCH" block returns the power generated by the inverter through the "STATIC BYPASS LINE" to the UPS input. This could become dangerous for an operator who is handling the input panel and who, having cut off the input power to the UPS, is surprised by the energy returned by the UPS. The external non-return system opens in the absence of energy in the input lines protecting against a possible return of energy from the UPS.

**\*\*\* NOTE: This UPS does not include Back feed protection system.**

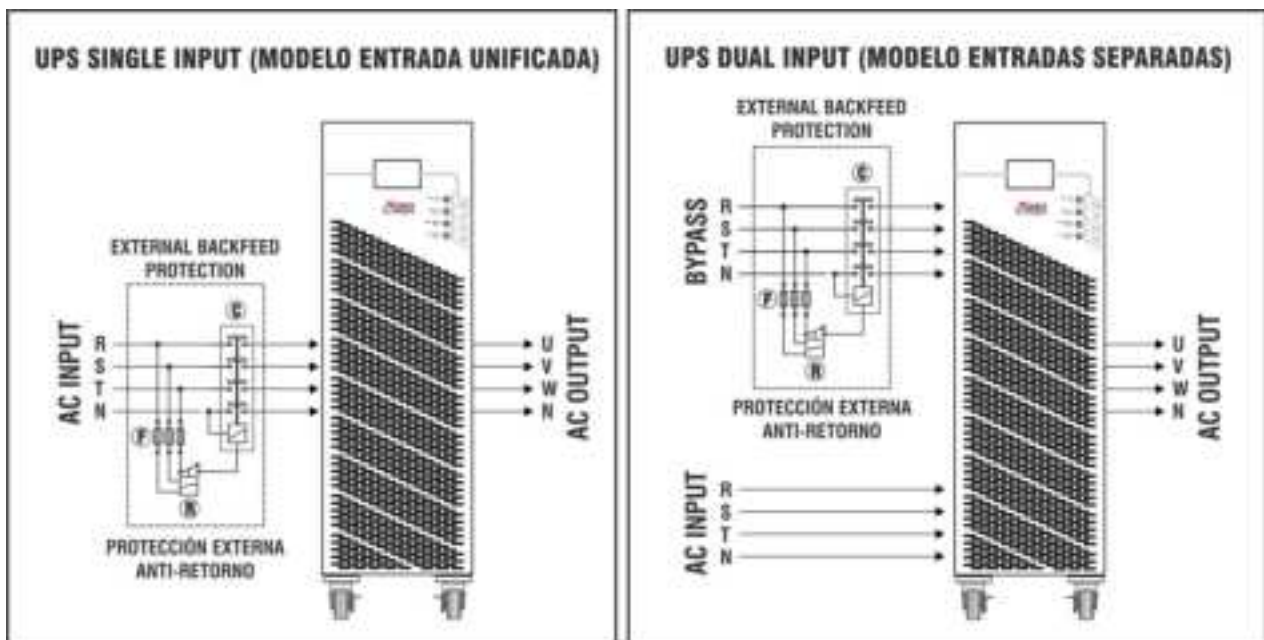

Standard model is Unified Input Model, with only one input Terminal Block for R-S-T-N, and internally Main AC input is separated from the internal bypass input.

Dual Inputs Model in which Main and Bypass have their own connection Terminal Block. For this version, Back-Feed protection must be connected to Bypass Input.

### Legend: Back-Feed Protection:

- C:** Normally open 4 poles Contactor with voltage coil according to operating voltage in AC INPUT. Current capacity according to maximum power in AC INPUT.
- R:** AC Relay with normally open contact of voltage according to operating voltage in AC INPUT.
- F:** General purpose standard AC Fuse with voltage according to operating voltage in AC INPUT.

**CIRCUIT BREAKERS AND WIRING SELECTION - 400/230V MODELS**

External circuit breakers, switches, and wire gauges must be able to handle currents indicated in the table shown below. Suggested values have been selected to ensure proper operation.

**NOTE:** Each country or region may have local regulations more demanding than the values suggested in this manual. In those cases, the requirements of the local regulations must be followed.

400/230VAC	INPUT (AC)	OUTPUT (AC)
MODEL	BREAKER & WIRING	BREAKER & WIRING
<b>10KVA (400/230VAC)</b>	<b>Max. Nominal Current (Line):</b> - 20A in normal mode (@200V) <b>Wiring (min. recommended size):</b> * Phase: 14AWG (2.5 mm <sup>2</sup> ) * Neutral: 10AWG (6 mm <sup>2</sup> )	<b>Max. Nominal Current (Line):</b> - 16A in normal mode (@220V) <b>Wiring (min. recommended size):</b> * Phase: 14AWG (2.5 mm <sup>2</sup> ) * Neutral: 10AWG (6 mm <sup>2</sup> )
<b>20KVA (400/230VAC)</b>	<b>Max. Nominal Current (Line):</b> - 38A in normal mode (@200V) <b>Wiring (min. recommended size):</b> * Phase: 10AWG (6 mm <sup>2</sup> ) * Neutral: 6AWG (16 mm <sup>2</sup> )	<b>Max. Nominal Current (Line):</b> - 33A in normal mode (@220V) <b>Wiring (min. recommended size):</b> * Phase: 10AWG (6 mm <sup>2</sup> ) * Neutral: 6AWG (16 mm <sup>2</sup> )
<b>30KVA (400/230VAC)</b>	<b>Max. Nominal Current (Line):</b> - 55A in normal mode (@200V) <b>Wiring (min. recommended size):</b> * Phase: 8AWG (10 mm <sup>2</sup> ) * Neutral: 4AWG (25 mm <sup>2</sup> )	<b>Max. Nominal Current (Line):</b> - 50A in normal mode (@220V) <b>Wiring (min. recommended size):</b> * Phase: 8AWG (10 mm <sup>2</sup> ) * Neutral: 4AWG (25 mm <sup>2</sup> )
<b>40KVA (400/230VAC)</b>	<b>Max. Nominal Current (Line):</b> - 75A in normal mode (@200V) <b>Wiring (min. recommended size):</b> * Phase: 6 AWG (16 mm <sup>2</sup> ) * Neutral: 3 AWG (35 mm <sup>2</sup> )	<b>Nominal Current (Line):</b> - 65A in normal mode (@220V) <b>Wiring (min. recommended size):</b> * Phase: 6 AWG (16 mm <sup>2</sup> ) * Neutral: 3 AWG (35 mm <sup>2</sup> )
<b>60KVA (400/230VAC)</b>	<b>Max. Nominal Current (Line):</b> - 110A in normal mode (@200V) <b>Wiring (min. recommended size):</b> * Phase: 3 AWG (35 mm <sup>2</sup> ) * Neutral: 1/0 AWG (70 mm <sup>2</sup> )	<b>Nominal Current (Line):</b> - 100A in normal mode (@220V) <b>Wiring (min. recommended size):</b> * Phase: 3 AWG (35 mm <sup>2</sup> ) * Neutral: 1/0 AWG (70 mm <sup>2</sup> )
<b>80KVA (400/230VAC)</b>	<b>Max. Nominal Current (Line):</b> - 145A in normal mode (@200V) <b>Wiring (min. recommended size):</b> * Phase: 2 AWG (35 mm <sup>2</sup> ) * Neutral: 3/0 AWG (95 mm <sup>2</sup> )	<b>Nominal Current (Line):</b> - 135A in normal mode (@220V) <b>Wiring (min. recommended size):</b> * Phase: 2 AWG (35 mm <sup>2</sup> ) * Neutral: 3/0 AWG (95 mm <sup>2</sup> )

CABLE SIZE RECOMMENDED ACCORDING TO '1999 NEC' (301-17) BASED ON AMBIENT TEMPERATURE 30°C - INDIVIDUAL CABLE.  
 ESTIMATED PHASE CURRENT IN NORMAL MODE WITH MINIMUM INPUT OF 200VAC PER PHASE  
 NEUTRAL CURRENT IS ESTIMATED TO BE 1.7 TIMES HIGHER THAN PHASE CURRENTS.

**WARNING:**

The reported wire gauges are merely recommendations and should be reviewed by the responsible electrician to adapt them to the installation. The sizing of the wiring is influenced by various factors such as operating temperature, length of the installation, cable type, and installation type. The electric contractor hired by the customer must ensure the proper selection of wiring and line protection devices in accordance with current local regulations. Wire colors should also comply with local regulations.

**CIRCUIT BREAKERS AND WIRING SELECTION - 208/120V MODELS**

External circuit breakers, switches, and wire gauges must be able to handle currents indicated in the table shown below. Suggested values have been selected to ensure proper operation.

**NOTE:** Each country or region may have local regulations more demanding than the values suggested in this manual. In those cases, the requirements of the local regulations must be followed.

208/120VAC	INPUT (AC)	OUTPUT (AC)
MODEL	BREAKER & WIRING	BREAKER & WIRING
<b>10KVA (208/120VAC)</b>	<b>Max. Nominal Current (Line):</b> - 36A in normal mode (@100V) <b>Wiring (min. recommended size):</b> * Phase: 10 AWG (6 mm <sup>2</sup> )	<b>Max. Nominal Current (Line):</b> - 34A in normal mode (@120V) <b>Wiring (min. recommended size):</b> * Phase: 10 AWG (6 mm <sup>2</sup> )
<b>20KVA (208/120VAC)</b>	<b>Max. Nominal Current (Line):</b> - 72A in normal mode (@100V) <b>Wiring (min. recommended size):</b> * Phase: 6 AWG (16 mm <sup>2</sup> )	<b>Max. Nominal Current (Line):</b> - 68A in normal mode (@120V) <b>Wiring (min. recommended size):</b> * Phase: 6 AWG (16 mm <sup>2</sup> )
<b>30KVA (208/120VAC)</b>	<b>Max. Nominal Current (Line):</b> - 110A in normal mode (@100V) <b>Wiring (min. recommended size):</b> * Phase: 3 AWG (35 mm <sup>2</sup> )	<b>Max. Nominal Current (Line):</b> - 100A in normal mode (@120V) <b>Wiring (min. recommended size):</b> * Phase: 3 AWG (35 mm <sup>2</sup> )
<b>40KVA (208/120VAC)</b>	<b>Max. Nominal Current (Line):</b> - 145A in normal mode (@100V) <b>Wiring (min. recommended size):</b> * Phase: 2 AWG (35 mm <sup>2</sup> )	<b>Nominal Current (Line):</b> - 135A in normal mode (@120V) <b>Wiring (min. recommended size):</b> * Phase: 2 AWG (35 mm <sup>2</sup> )

**CABLE SIZE RECOMMENDED ACCORDING TO '1999 NEC' (301-17) BASED ON AMBIENT TEMPERATURE 30°C - INDIVIDUAL CABLE.  
 ESTIMATED PHASE CURRENT IN NORMAL MODE WITH MINIMUM INPUT OF 200VAC PER PHASE  
 NEUTRAL CURRENT IS ESTIMATED TO BE 1.7 TIMES HIGHER THAN PHASE CURRENTS.**

**WARNING:** 

The reported wire gauges are merely recommendations and should be reviewed by the responsible electrician to adapt them to the installation. The sizing of the wiring is influenced by various factors such as operating temperature, length of the installation, cable type, and installation type. The electric contractor hired by the customer must ensure the proper selection of wiring and line protection devices in accordance with current local regulations. Wire colors should also comply with local regulations.

**6.- SINGLE UPS WIRING: TERMINAL BLOCK & EXTERNAL BATTERIES**

**CABLE ENTRY AND PASSAGE - 400/230V AND 480/277V MODELS UPS:**

From 10K to 40K Models, 400/230V and 480/277V, cables enter through the back, through an opening below the Terminal Block cover plate.  
For 60K and 80K Models, 400/230V and 480/277V, cables enter through the bottom at the front plane of UPS cabinet.

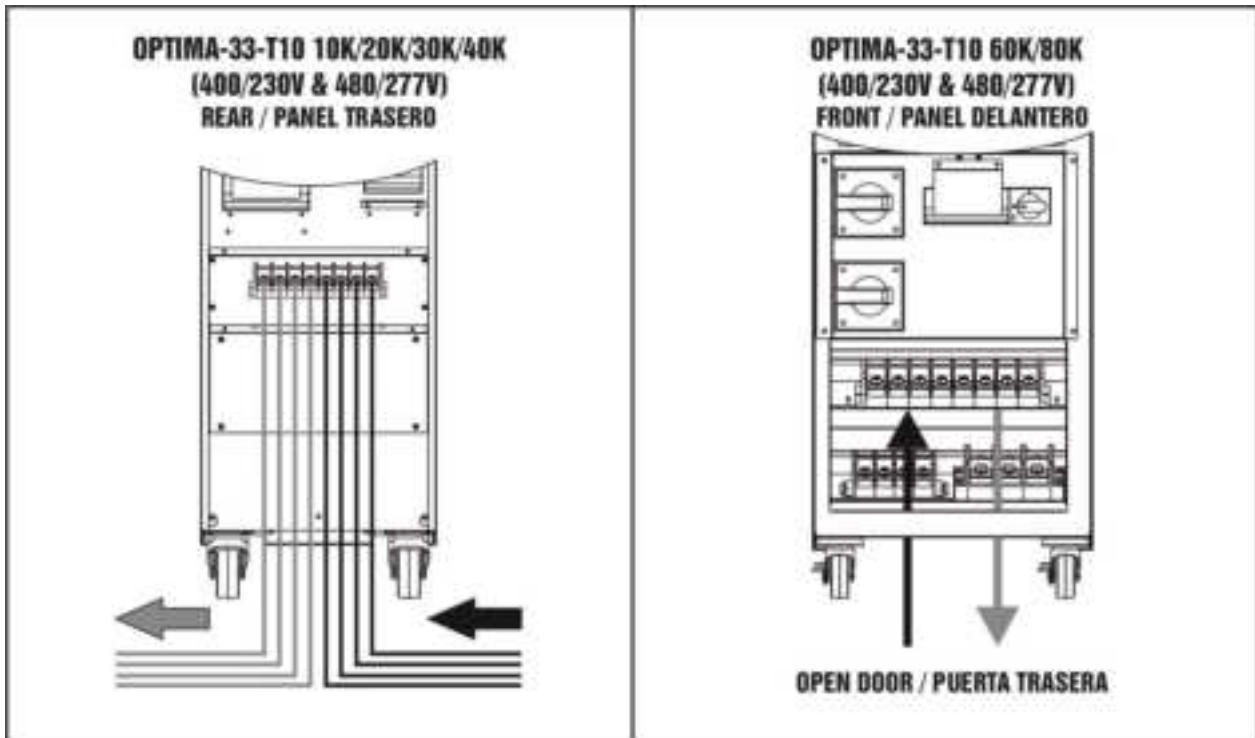

**CABLE ENTRY AND PASSAGE - 208/120V MODELS UPS:**

For 10K and 20K models, 208/120V, cables enter through the back.  
For 30K and 40K models, 208/120V, cables enter through the bottom at the front plane of UPS cabinet.

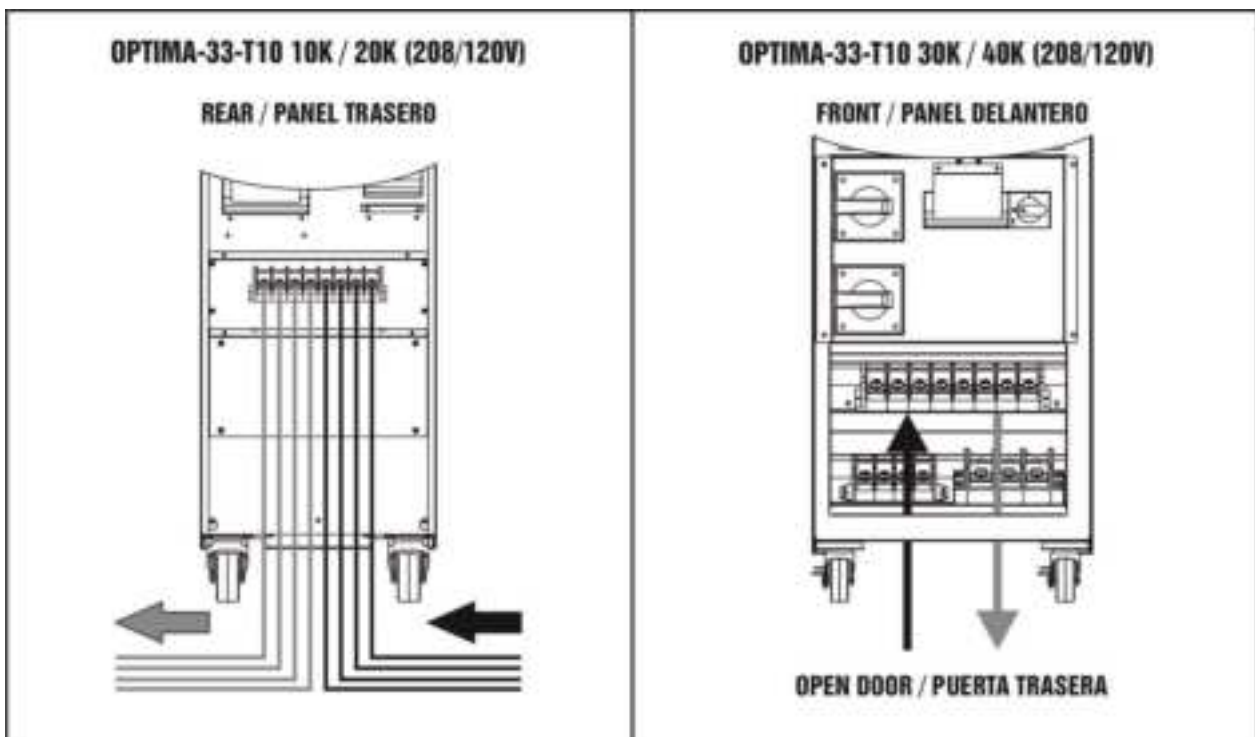

**AC LINES CONNECTION**



- \* Make sure the UPS is Off before starting the installation.
- \* Remember to check all wires to be connected are not powered (including external batteries).

**TERMINAL BLOCK PREPARATION**

Remove TB cover located on rear side of UPS. Each line must be protected by a Circuit Breaker.  
For safety, GROUND cables must be first to be connected and last to be disconnected from UPS.

**REAR ACCESS MODELS:**

Terminal Block is located at UPS rear panel. Safety plate cover must be removed.

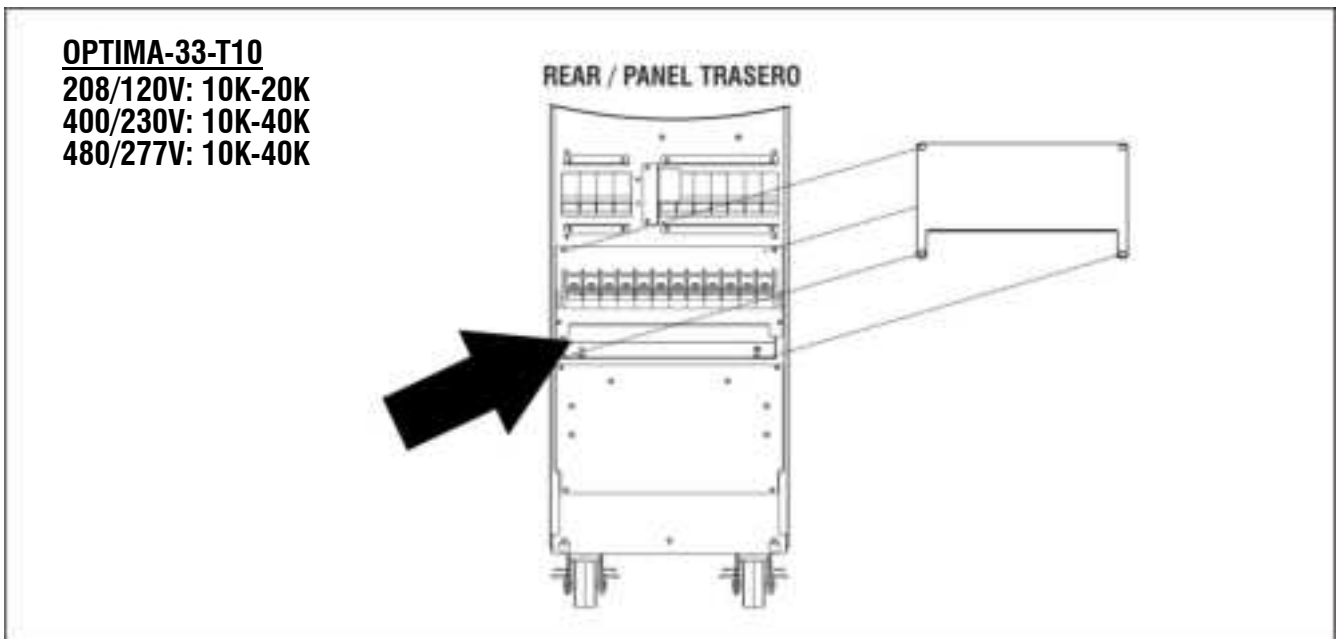

**FRONT ACCESS MODELS:**

Terminal Block is located at UPS front panel. Open the front door and remove safety plate cover.

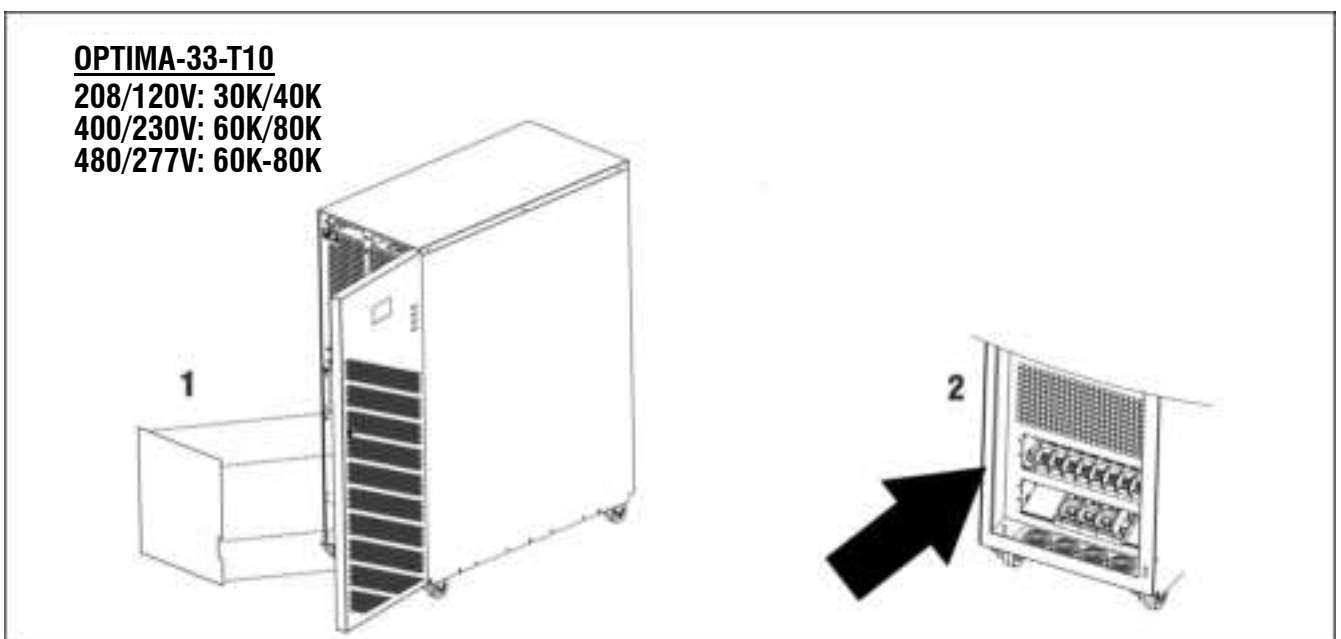

**TERMINAL BLOCKS – 400/230V & 480/277V MODELS**

**IMPORTANT:** For systems with Dual Input (Main and Bypass), jumpers that come factory-connected between UPS inputs (Main and Bypass) must be disconnected.  
For installations with single power source (which is the most common), jumpers should be kept and power service connected to the AC INPUT Terminal Block.

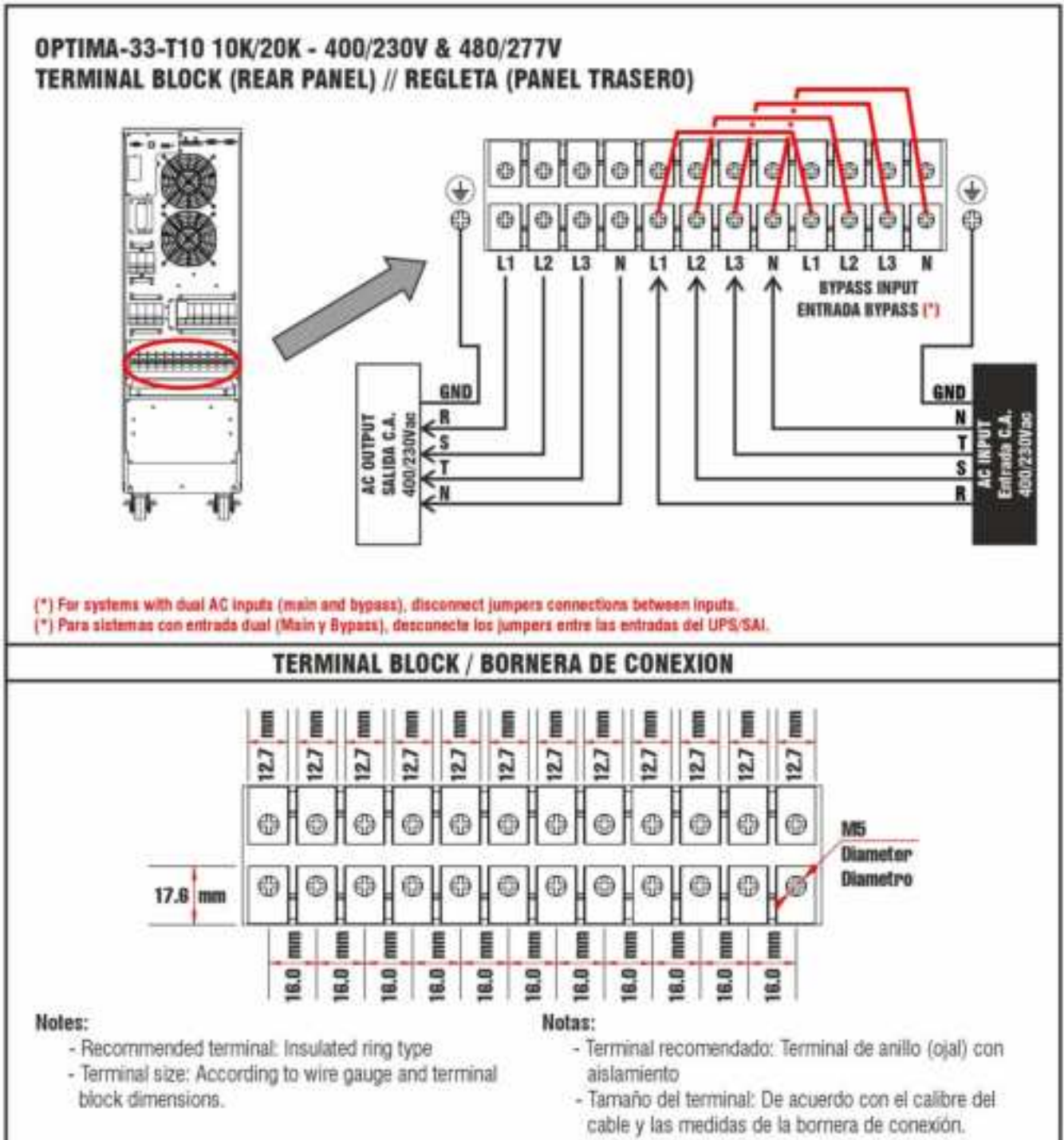

**OPTIMA-33-T10 30K/40K - 400/230V & 480/277V  
TERMINAL BLOCK (REAR PANEL) // REGLETA (PANEL TRASERO)**

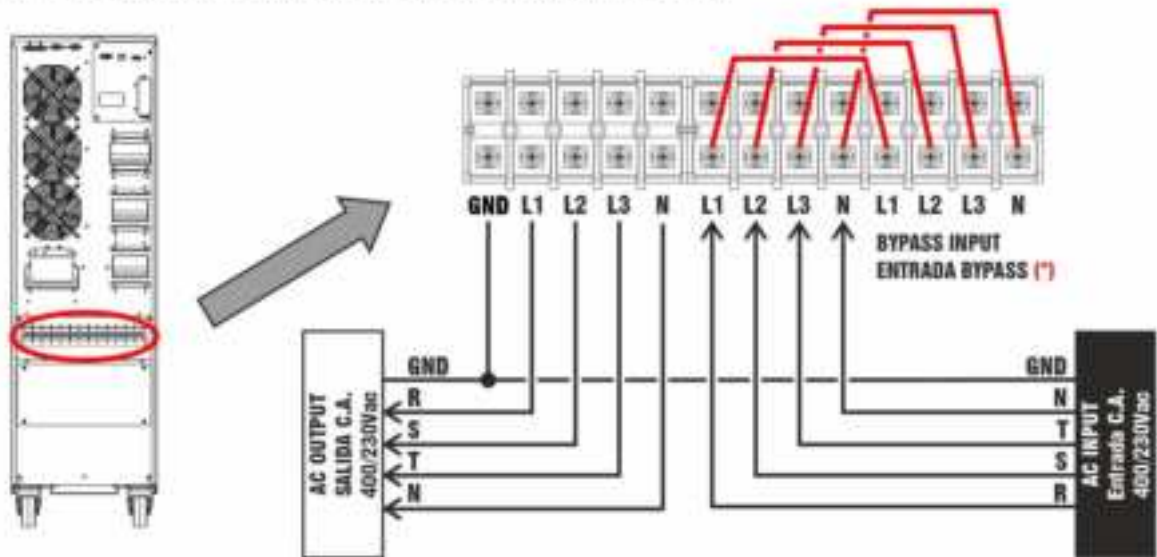

(\*) For systems with dual AC inputs (main and bypass), disconnect jumpers connections between inputs.  
(\*) Para sistemas con entrada dual (Main y Bypass), desconecte los jumpers entre las entradas del UPS/SAI.

**TERMINAL BLOCK / BORNERA DE CONEXION**

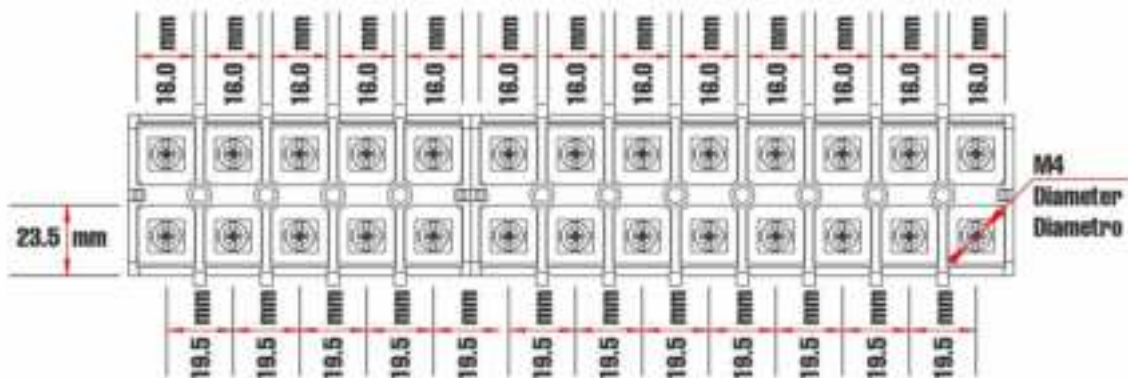

**Notes:**

- Recommended terminal: Insulated ring type
- Terminal size: According to wire gauge and terminal block dimensions.

**Notas:**

- Terminal recomendado: Terminal de anillo (ojal) con aislamiento
- Tamaño del terminal: De acuerdo con el calibre del cable y las medidas de la bornera de conexión.

**OPTIMA-33-T10 60K/80K - 400/230V & 480/277V**  
**TERMINAL BLOCK (FRONT PANEL) // REGLETA (PANEL DELANTERO)**

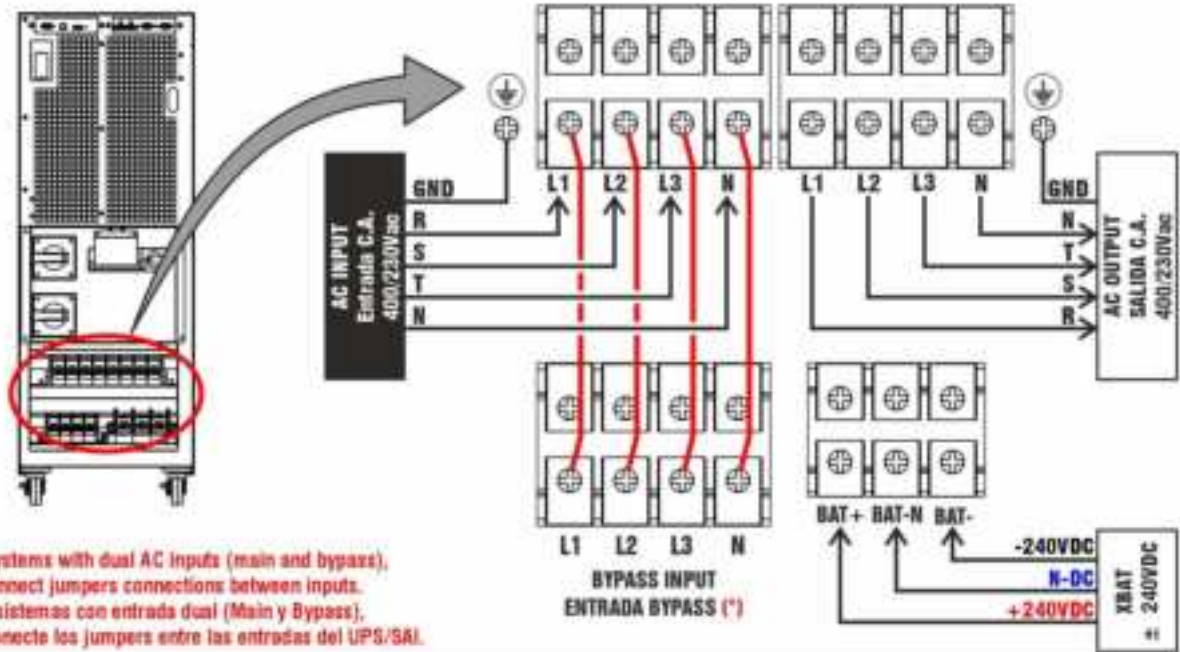

(\*) For systems with dual AC inputs (main and bypass), disconnect jumpers connections between inputs.  
 (\*) Para sistemas con entrada dual (Main y Bypass), desconecte los jumpers entre las entradas del UPS/SAL.

**TERMINAL BLOCK / BORNERA DE CONEXION**

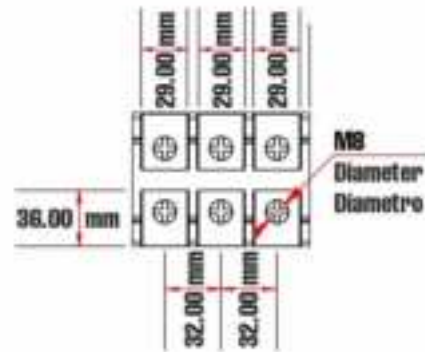
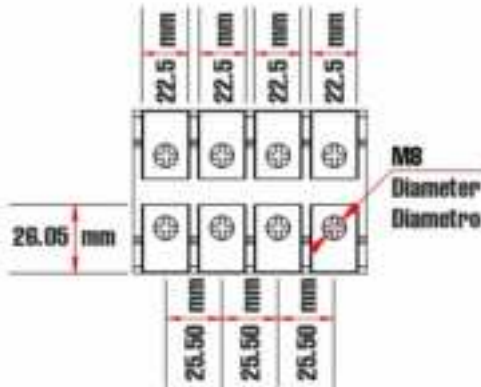

**Notes:**

- Recommended terminal: Insulated ring type
- Terminal size: According to wire gauge and terminal block dimensions.

**Notas:**

- Terminal recomendado: Terminal de anillo (ojal) con aislamiento
- Tamaño del terminal: De acuerdo con el calibre del cable y las medidas de la bornera de conexión.

**TERMINAL BLOCKS –208/120V MODELS**

**IMPORTANT:** For systems with Dual Input (Main and Bypass), jumpers that come factory-connected between UPS inputs (Main and Bypass) must be disconnected.  
For installations with single power source (which is the most common), jumpers should be kept and power service connected to the AC INPUT Terminal Block.

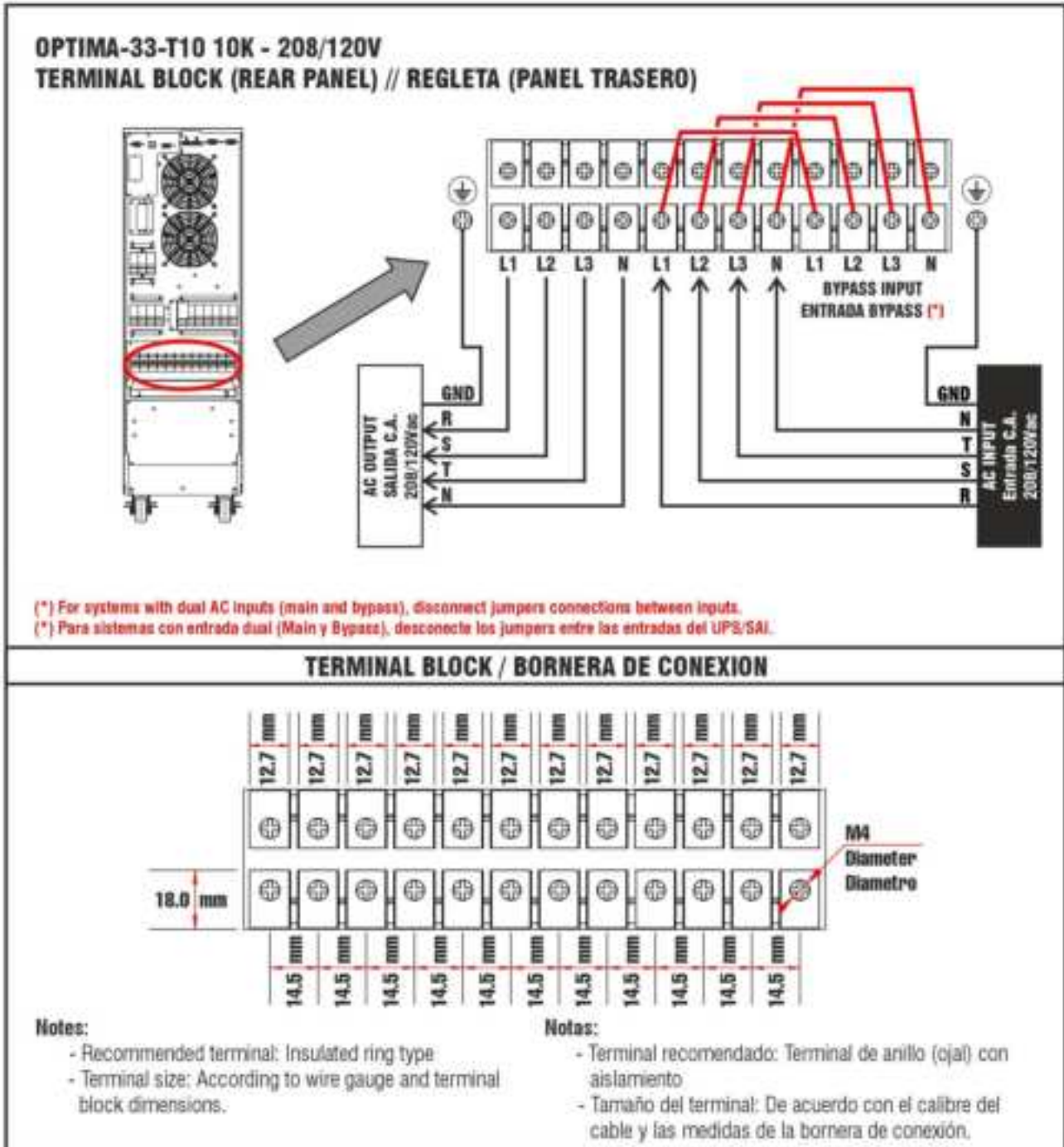

**OPTIMA-33-T10 20K - 208/120V**  
**TERMINAL BLOCK (REAR PANEL) // REGLETA (PANEL TRASERO)**

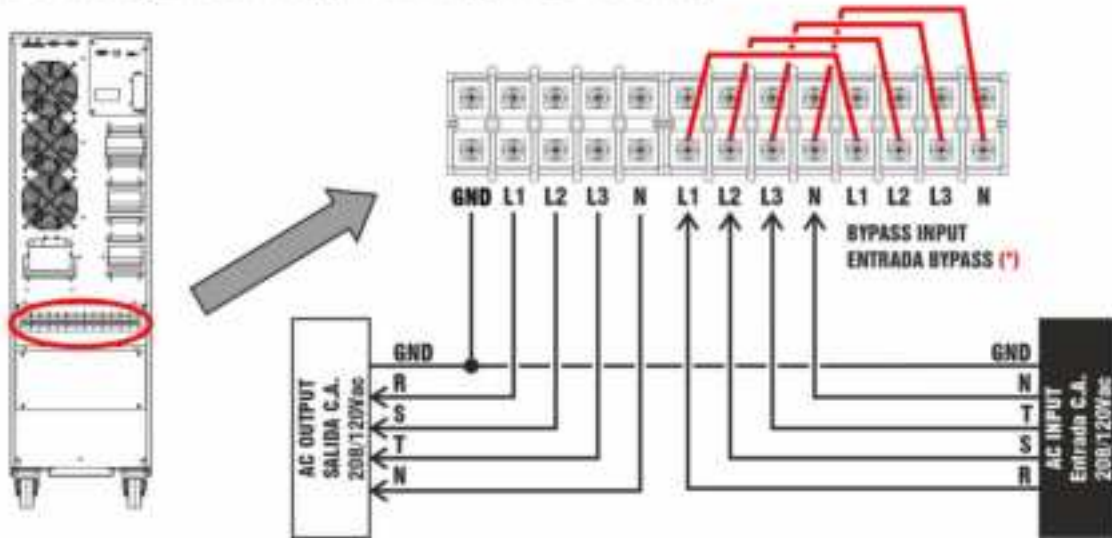

(\*) For systems with dual AC inputs (main and bypass), disconnect jumpers connections between inputs.  
 (\*) Para sistemas con entrada dual (Main y Bypass), desconecte los jumpers entre las entradas del UPS/SAI.

**TERMINAL BLOCK / BORNERA DE CONEXION**



**Notes:**

- Recommended terminal: Insulated ring type
- Terminal size: According to wire gauge and terminal block dimensions.

**Notas:**

- Terminal recomendado: Terminal de anillo (cjal) con aislamiento
- Tamaño del terminal: De acuerdo con el calibre del cable y las medidas de la bornera de conexión.

**OPTIMA-33-T10 30K/40K - 208/120V**  
**TERMINAL BLOCK (FRONT PANEL) // REGLETA (PANEL DELANTERO)**

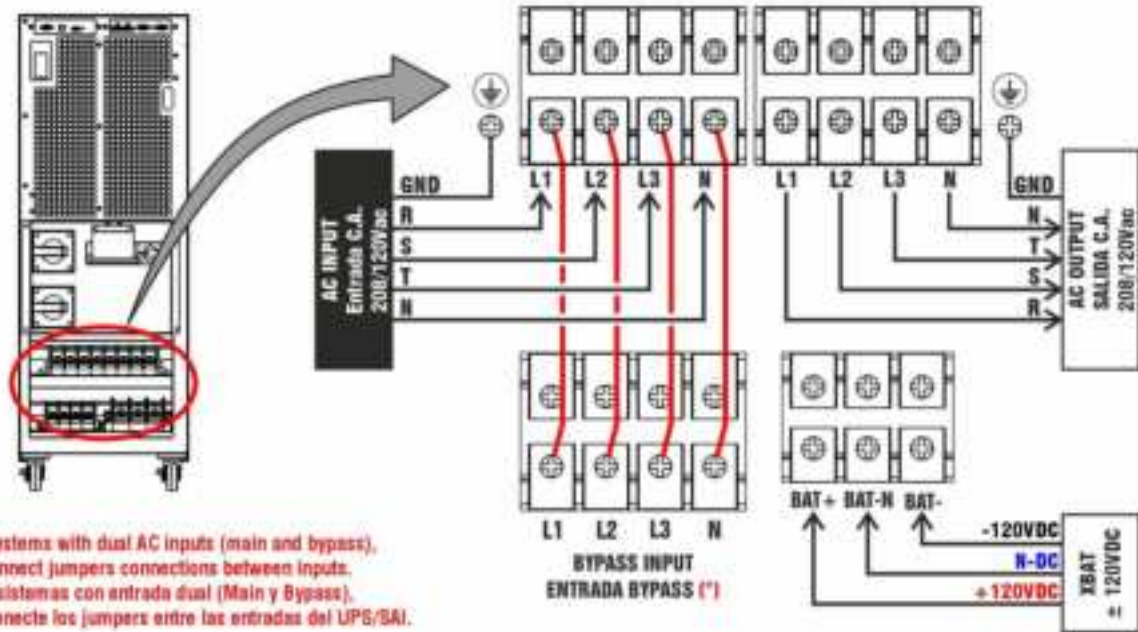

(\*) For systems with dual AC inputs (main and bypass), disconnect jumpers connections between inputs.  
 (\*) Para sistemas con entrada dual (Main y Bypass), desconecte los jumpers entre las entradas del UPS/SAI.

**TERMINAL BLOCK / BORNERA DE CONEXION**

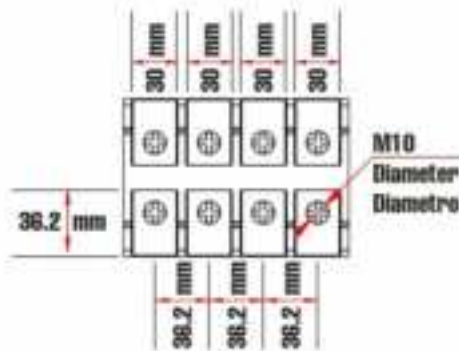

**Notes:**

- Recommended terminal: Insulated ring type
- Terminal size: According to wire gauge and terminal block dimensions.

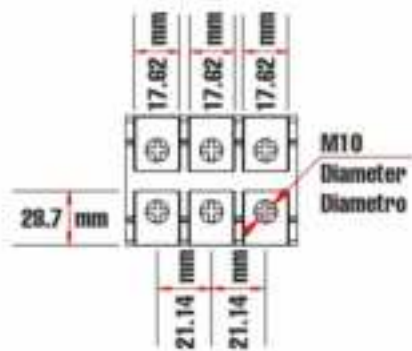

**Notas:**

- Terminal recomendado: Terminal de anillo (cjal) con aislamiento
- Tamaño del terminal: De acuerdo con el calibre del cable y las medidas de la bornera de conexión.

**EXTERNAL BATTERY CONNECTION**

Each model of OPTIMA-33 UPS from 10K to 80K has its own DC battery voltage. If external Battery Packs are required, it is mandatory to respect DC Voltage according to selected UPS model. Battery Packs have 3 connection points to UPS:

1. BATT (+)
2. BATT NEUTRAL
3. BATT (-)

Following tables show DC voltages per model:

UPS (400/230V & 480/277V)	KVA	BATTERY DC VOLTAGE
OPT33-T10-10K-400	10K	240VDC = (+120VDC) / (-120VDC)
OPT33-T10-20K-400	20K	480VDC = (+240VDC) / (-240VDC)
OPT33-T10-30K-400	30K	480VDC = (+240VDC) / (-240VDC)
OPT33-T10-40K-400	40K	480VDC = (+240VDC) / (-240VDC)
OPT33-T10-60K-NB-400	60K	480VDC = (+240VDC) / (-240VDC)
OPT33-T10-80K-NB-400	80K	480VDC = (+240VDC) / (-240VDC)

UPS (208/120V)	KVA	BATTERY DC VOLTAGE
OPT33-T10-10K-208	10K	240VDC = (+120VDC) / (-120VDC)
OPT33-T10-20K-208	20K	240VDC = (+120VDC) / (-120VDC)
OPT33-T10-30K-NB-208	30K	240VDC = (+120VDC) / (-120VDC)
OPT33-T10-40K-NB-208	40K	240VDC = (+120VDC) / (-120VDC)

Positive voltages are measured from BATT (+) to BATT Neutral  
 Negative voltages are measured from BATT (-) to BATT Neutral

**BATTERY PACKS XBAT-OPT33:**

Transportable cabinets with preinstalled 12V/9AH batteries.

We offer 2 versions according to size. Each size is available in 2 DC voltages: (+/-120VDC and +/-240VDC)

Appearance of Battery Pack is like Optima-33 family UPS. Requires a small installation place.

- DC Connector Max. Current: 120A per contact.
- Breaker Max. Current: 125A / 500VDC.

**For 40 batteries:**

**XBAT-OPT33-120V-40P:** 40 12V/9AH batteries. DC voltage: +/- 120V. DC Connector: 3 contacts (120A Max.)

**XBAT-OPT33-240V-40P:** 40 12V/9AH batteries. DC voltage: +/- 240V. Terminal Block: 3 terminals (240A Max.)

**For 80 batteries:**

**XBAT-OPT33-120V-80P:** 80 12V/9AH batteries. DC voltage: +/- 120V. DC Connector: 3 contacts (120A Max.)

**XBAT-OPT33-240V-80P:** 80 12V/9AH batteries. DC voltage: +/- 240V. Terminal Block: 3 terminals (240A Max.)

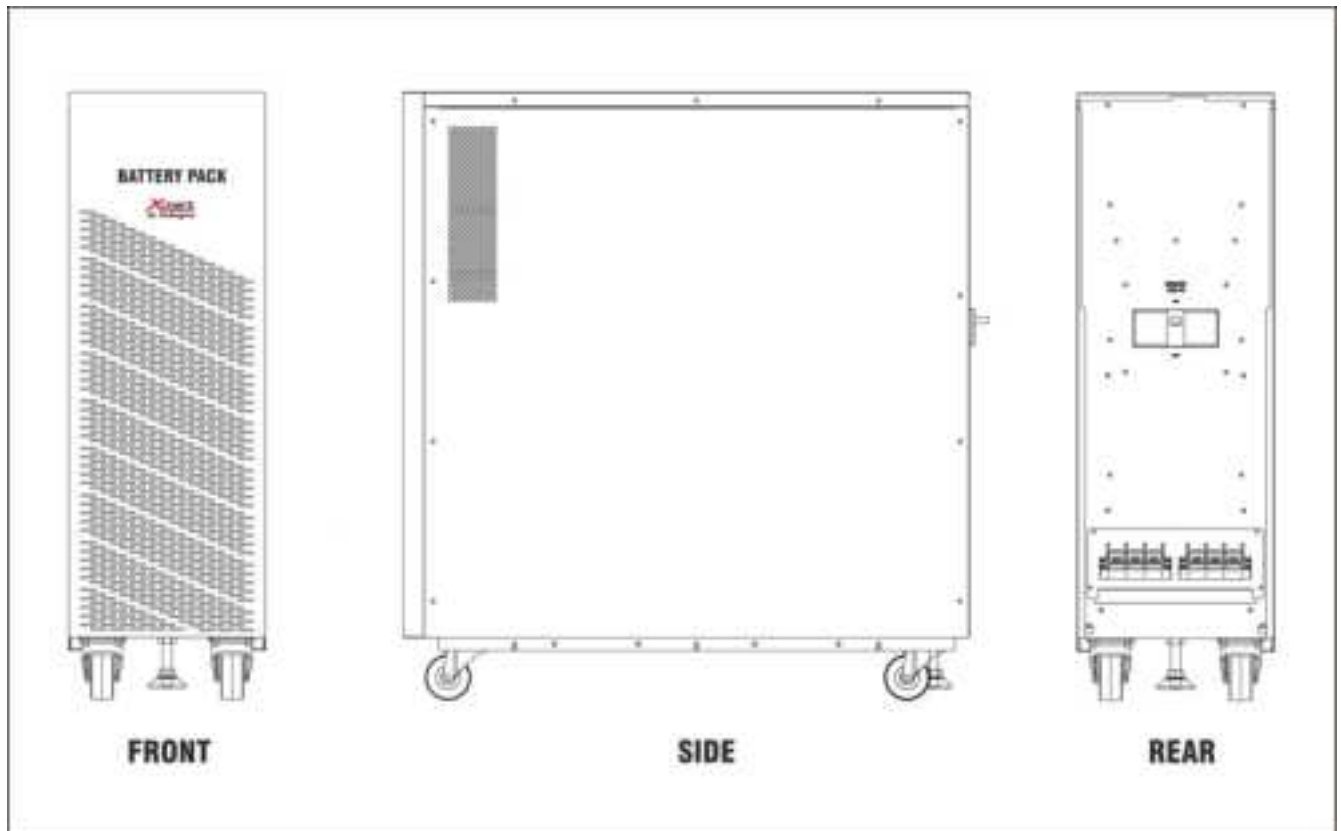

**EXTERNAL BATTERIES CONNECTION INSTRUCTIONS**

This section explains instructions to connect each UPS model with corresponding XBAT battery pack.

**UPS DC CONNECTORS**

UPS models with rear connection include internal batteries, except for the 480/277V models, which do not include batteries. If external batteries are required, they can be connected via a DC connector located on the rear panel. XMART battery packs come with DC connection cable to connect to the UPS:

- 208/120V: 10K & 20K
- 400/230V & 480/277V: 10K, 20K, 30K, & 40K

For UPS models with frontal connection, batteries are always external and can be connected to UPS via a 3 points Terminal Block, located on the UPS front panel, under AC Connection Terminal Blocks.

- 208/120V: 30K & 40K
- 400/230V & 480/277V: 60K & 80K

Next images show available connections and voltages:

**480VDC = (+240VDC) / (-240VDC)**

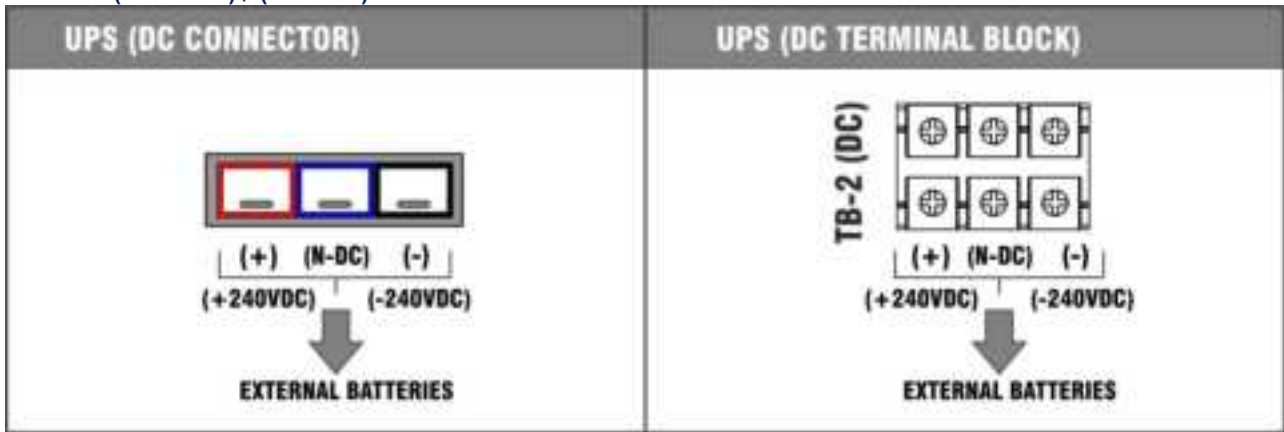

**240VDC = (+120VDC) / (-120VDC)**

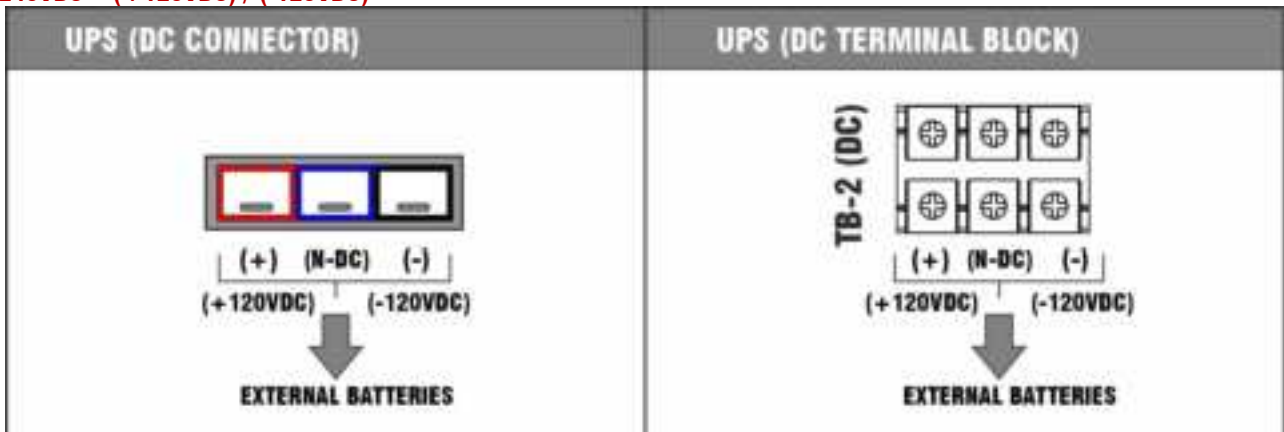

**WARNING:** If original XMART cables are not used, it must be verified that the gauge of the cables provided by the user can handle the expected DC current for each XBAT. Max. current depends on the selected scheme. Max. DC current of each XBAT can be calculated by dividing the power in VA required for each XBAT by the DC voltage.

**INSTRUCTIONS:**

1. Make sure the switches or fuse holders of each XBAT are in the OFF position.
2. Remove the covers that protect the DC connector on the UPS. Do the same on the XBAT.
3. Check with a voltmeter that terminals and connectors you will be working on do not present dangerous voltages.
4. Using the cable supplied with the equipment, connect the UPS to the first XBAT. In case of multiple XBATS, connect XBAT #1 to XBAT #2 and so on up to the last XBAT.

5. BEFORE STARTING THE UPS, sequentially close the switches or fuse holders of the XBATS to connect all the external battery packs in parallel to the UPS.

**RECOMMENDATION:**

In case it is necessary to connect more than one cable at the same point on the terminal block, it is suggested to reverse the position of the terminals to facilitate the connection and improve contact with the terminal block, as shown in the following figure:

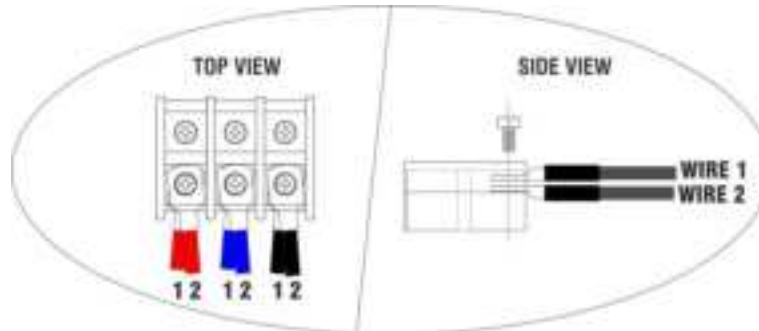

EXTERNAL BATTERY CONNECTION:

UPS 208/120V: 10K

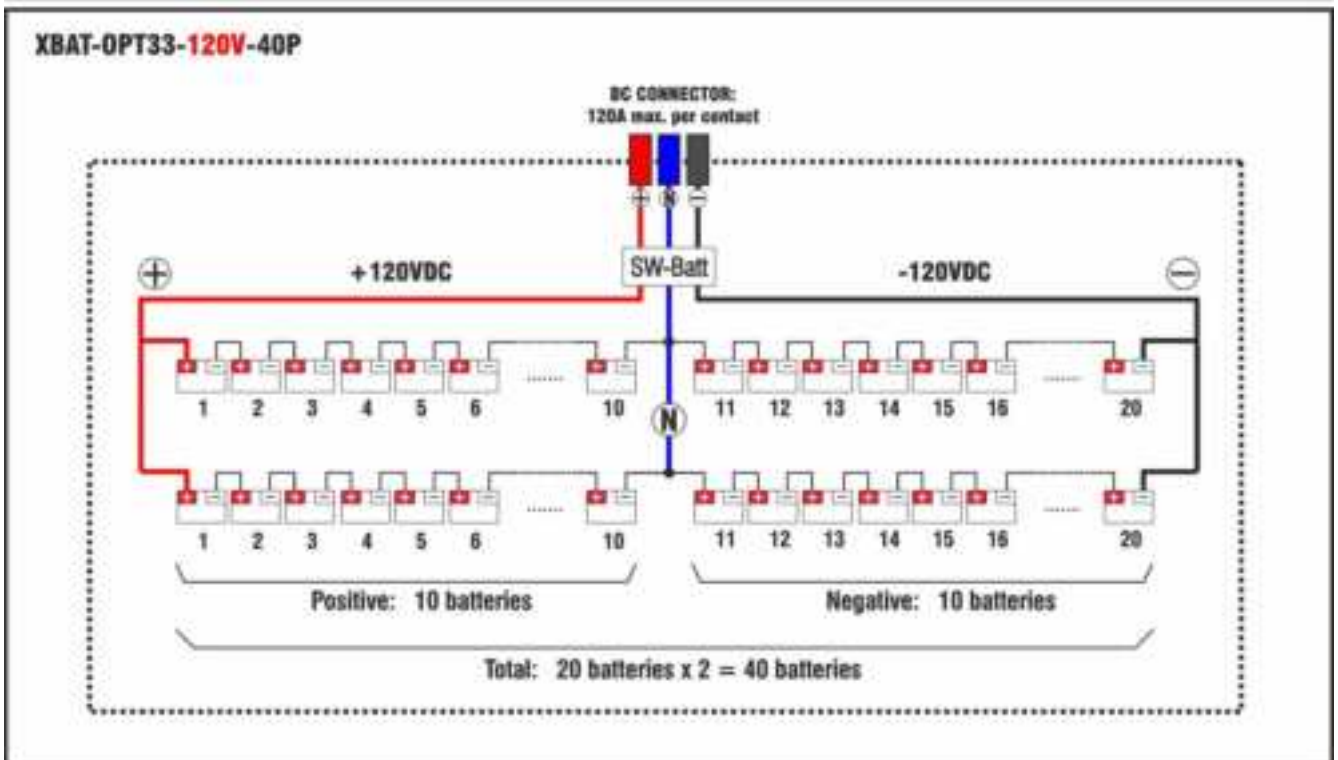
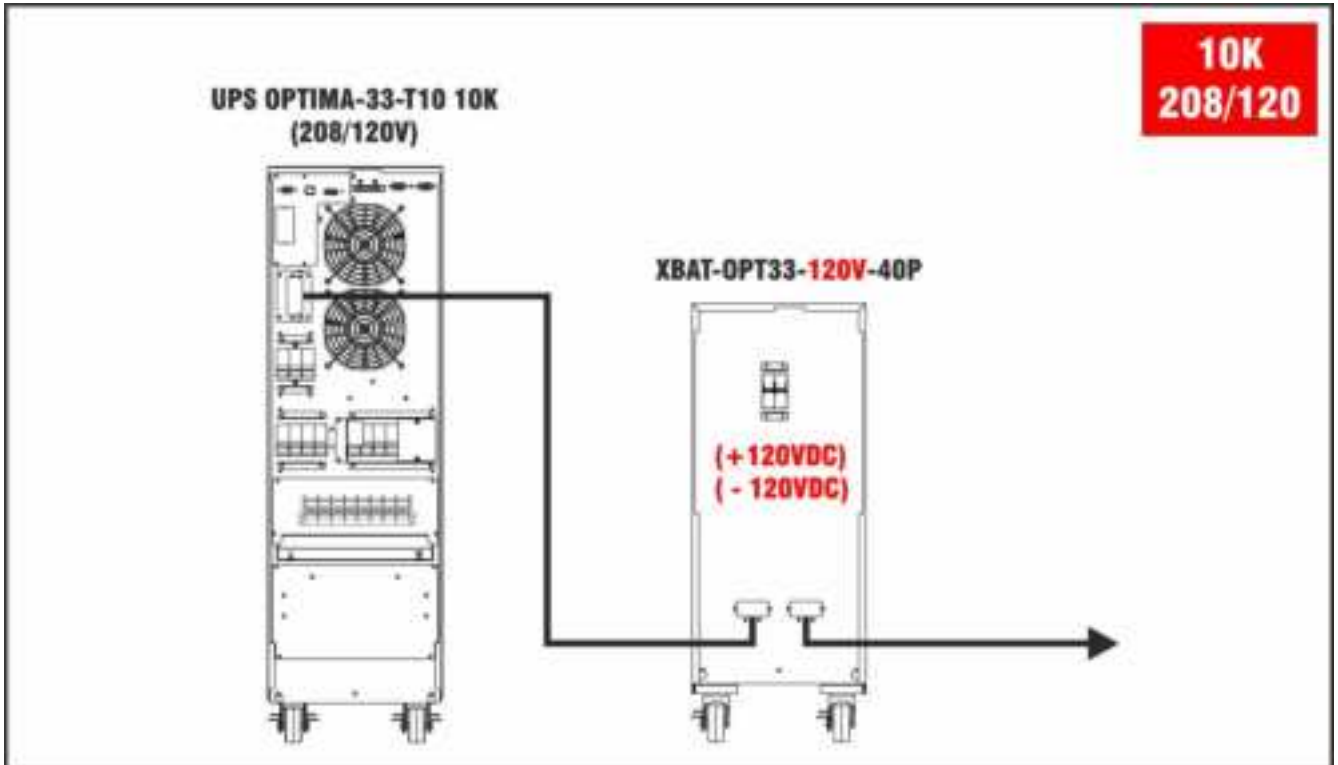

EXTERNAL BATTERY CONNECTION:

UPS 208/120V: 20K

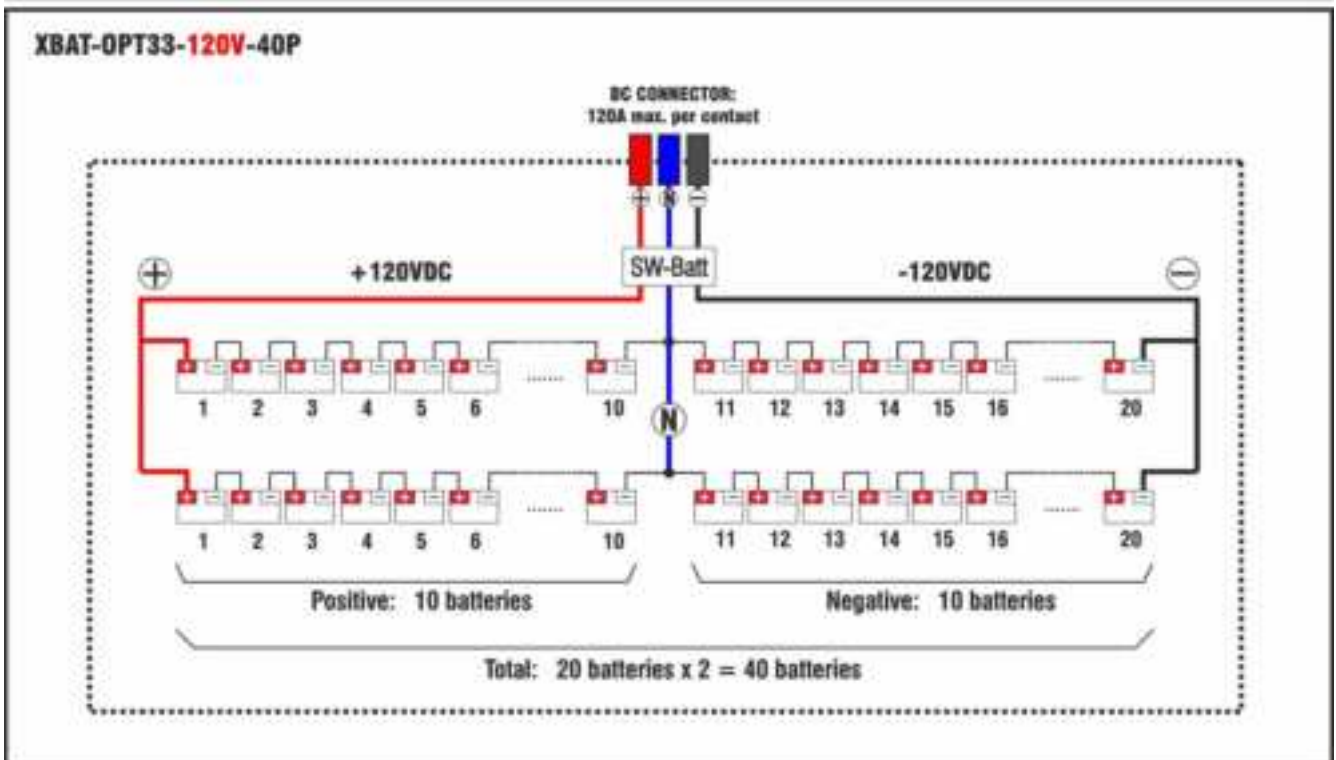
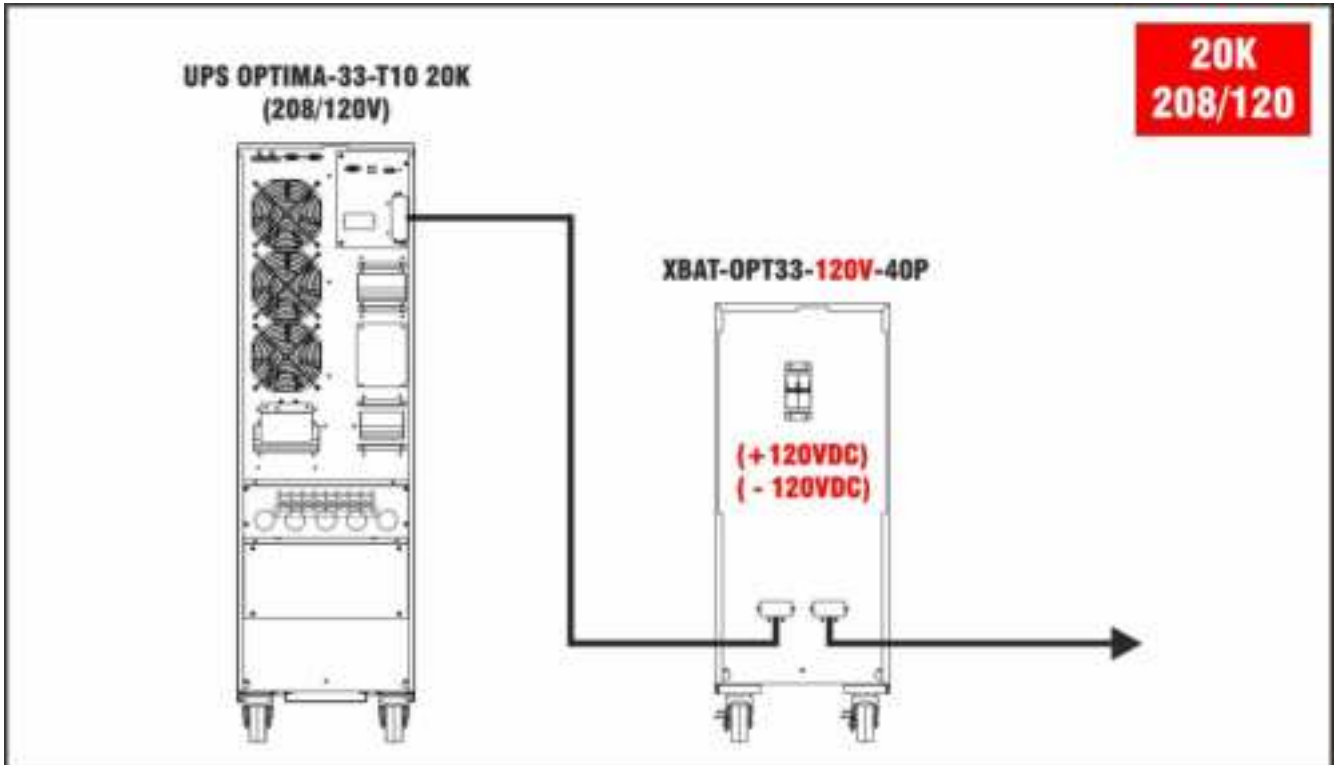

EXTERNAL BATTERY CONNECTION:

UPS 208/120V: 30K

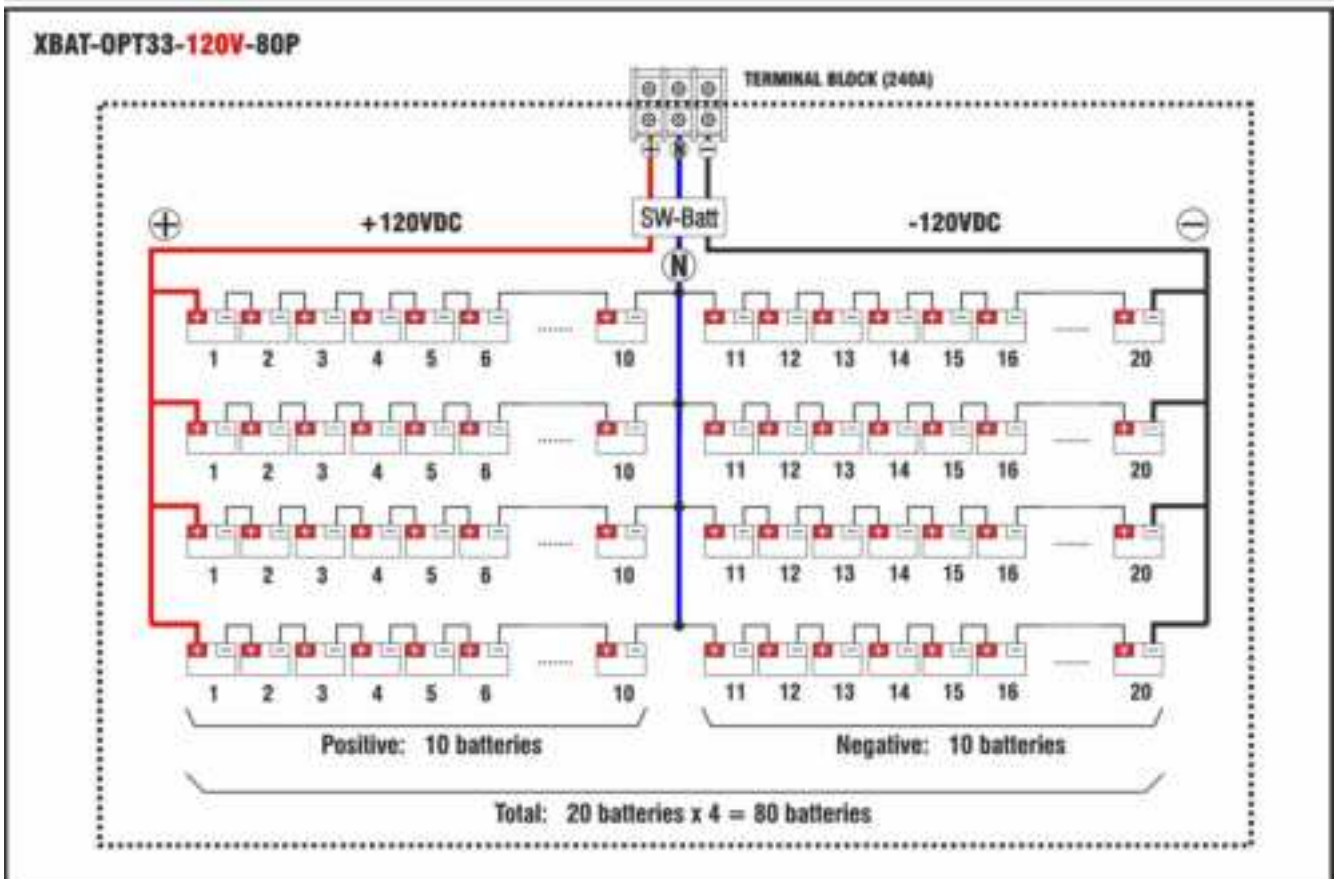
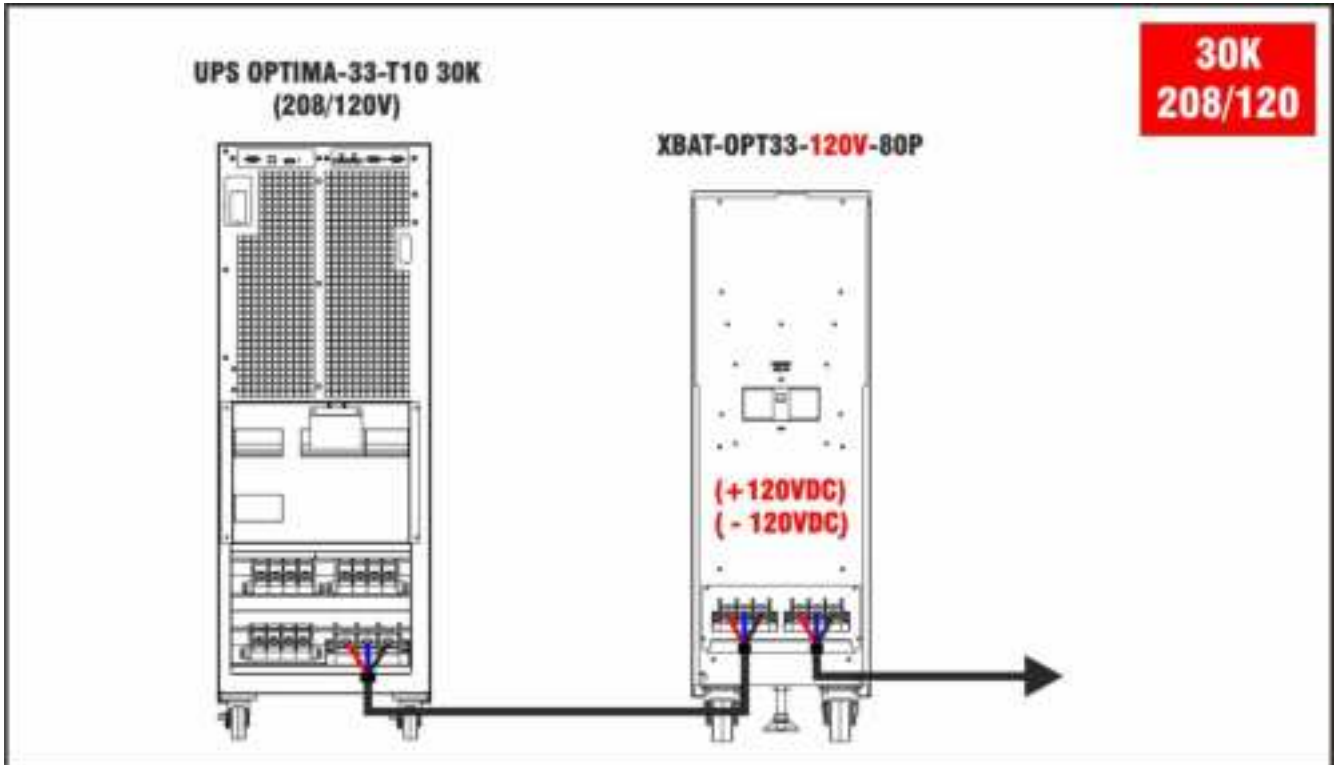

EXTERNAL BATTERY CONNECTION:

UPS 208/120V: 40K

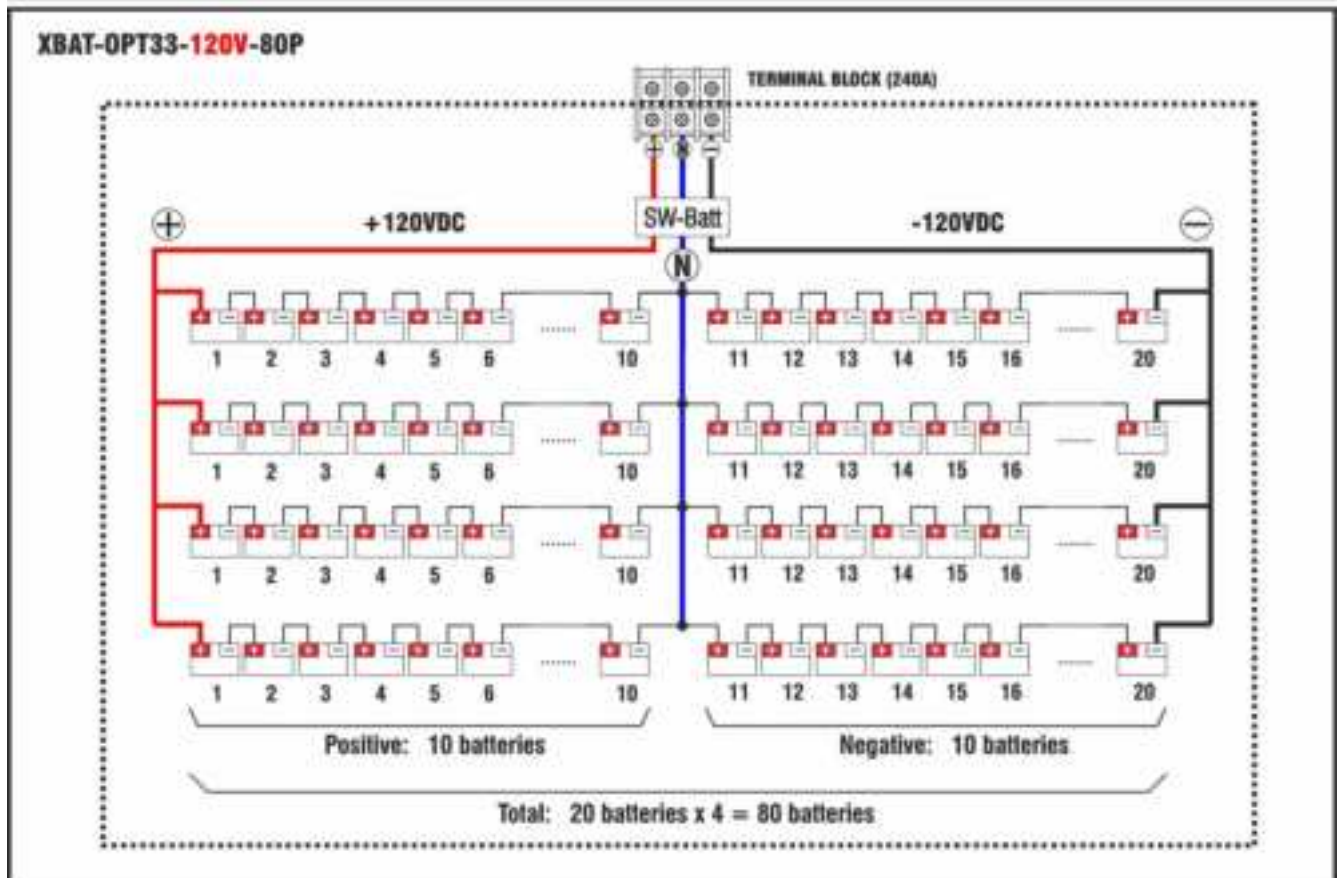
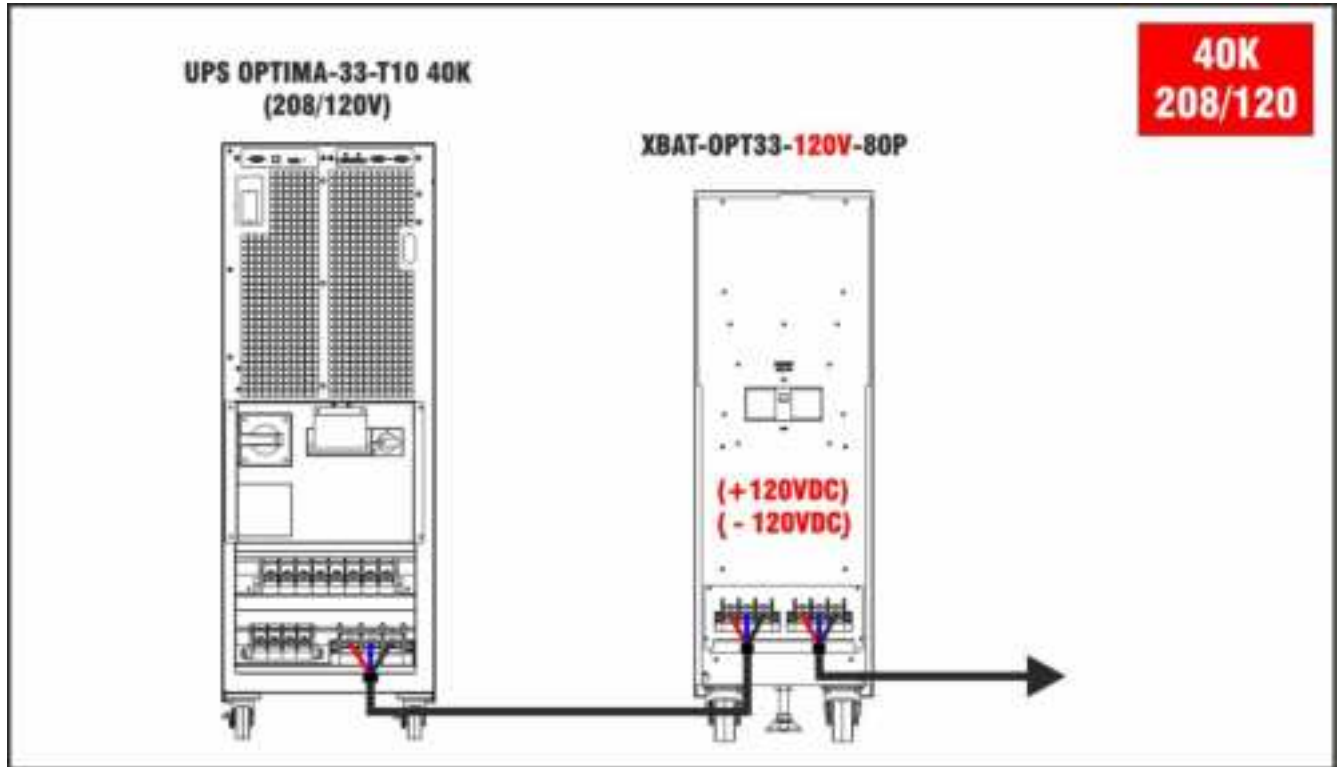

EXTERNAL BATTERY CONNECTION:

UPS 400/230V & 480/277V: 10K

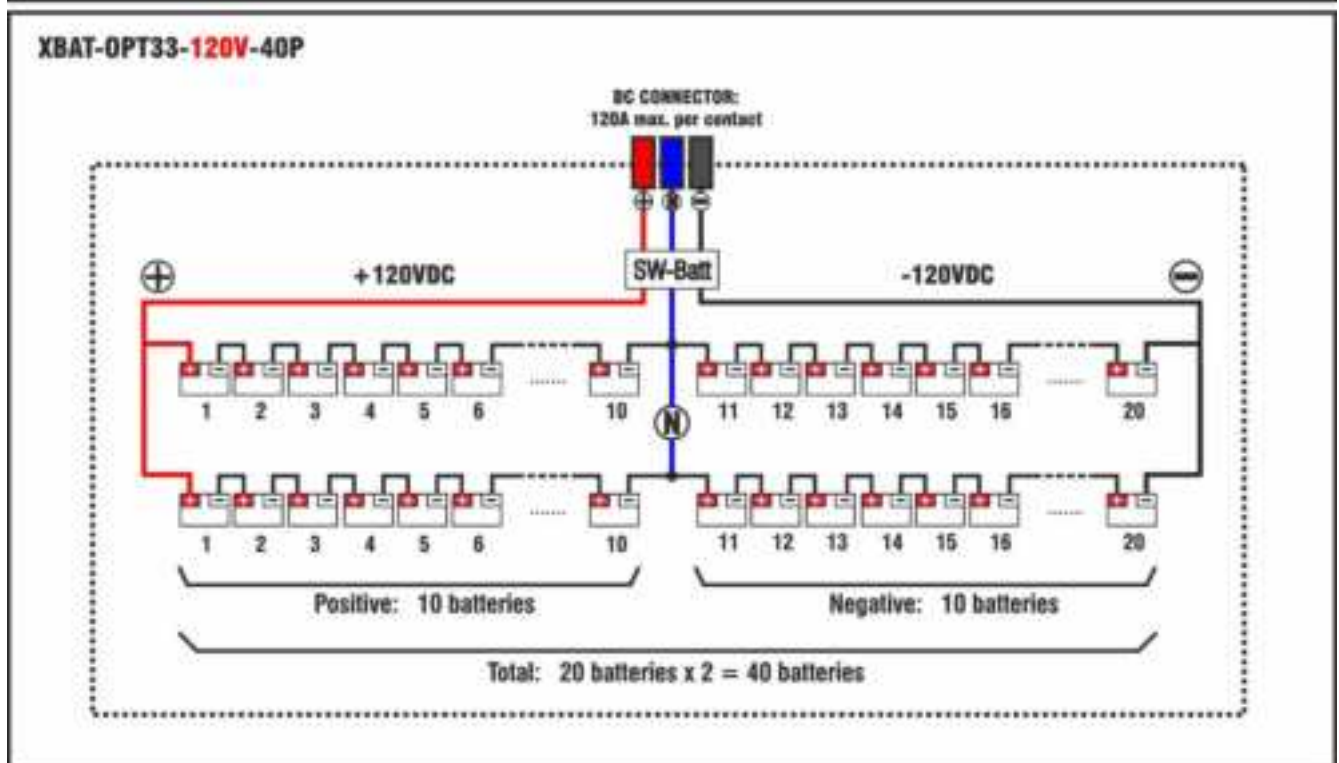
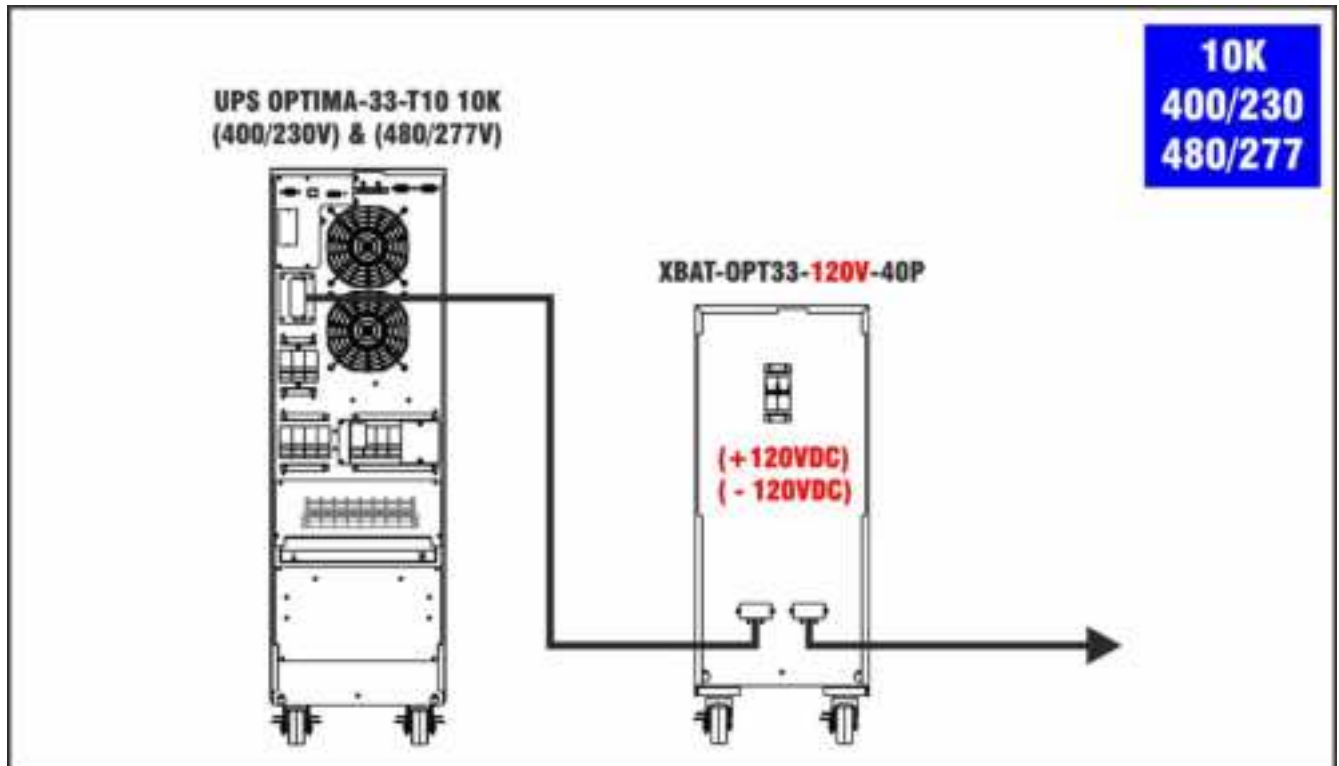

EXTERNAL BATTERY CONNECTION:

UPS 400/230V & 480/277V: 20K

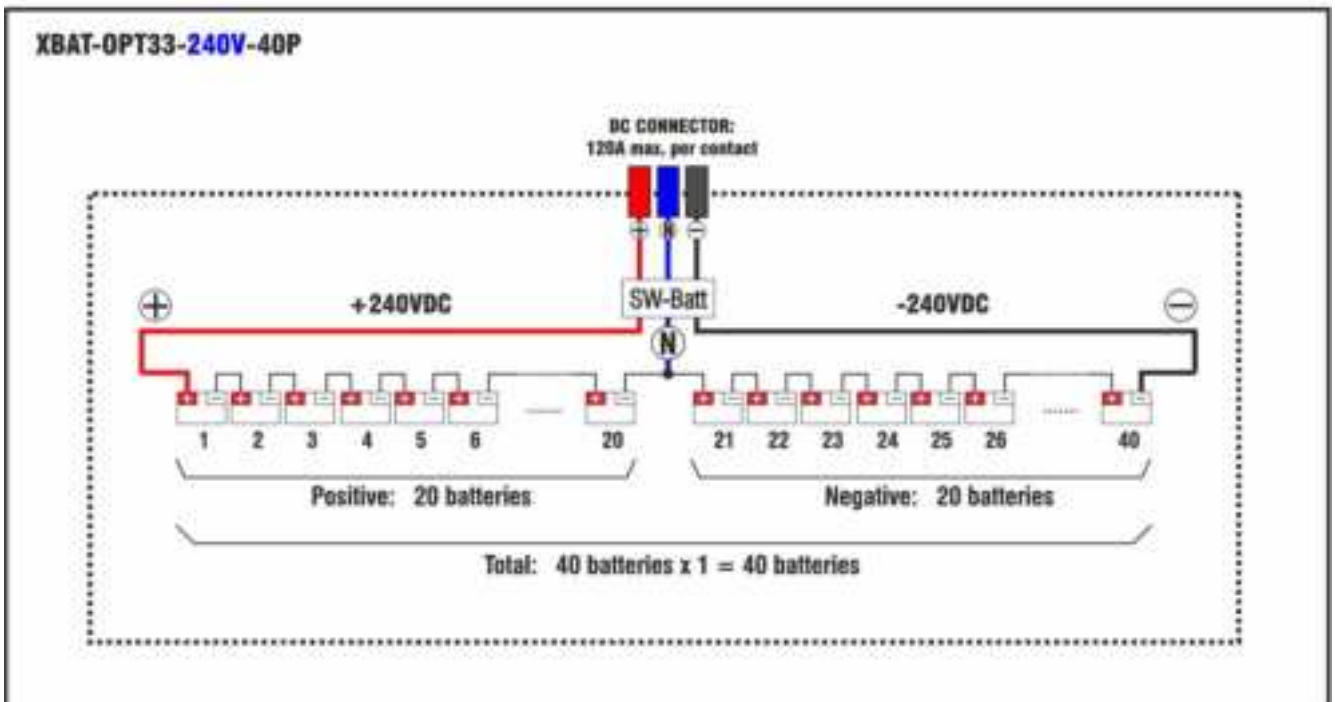
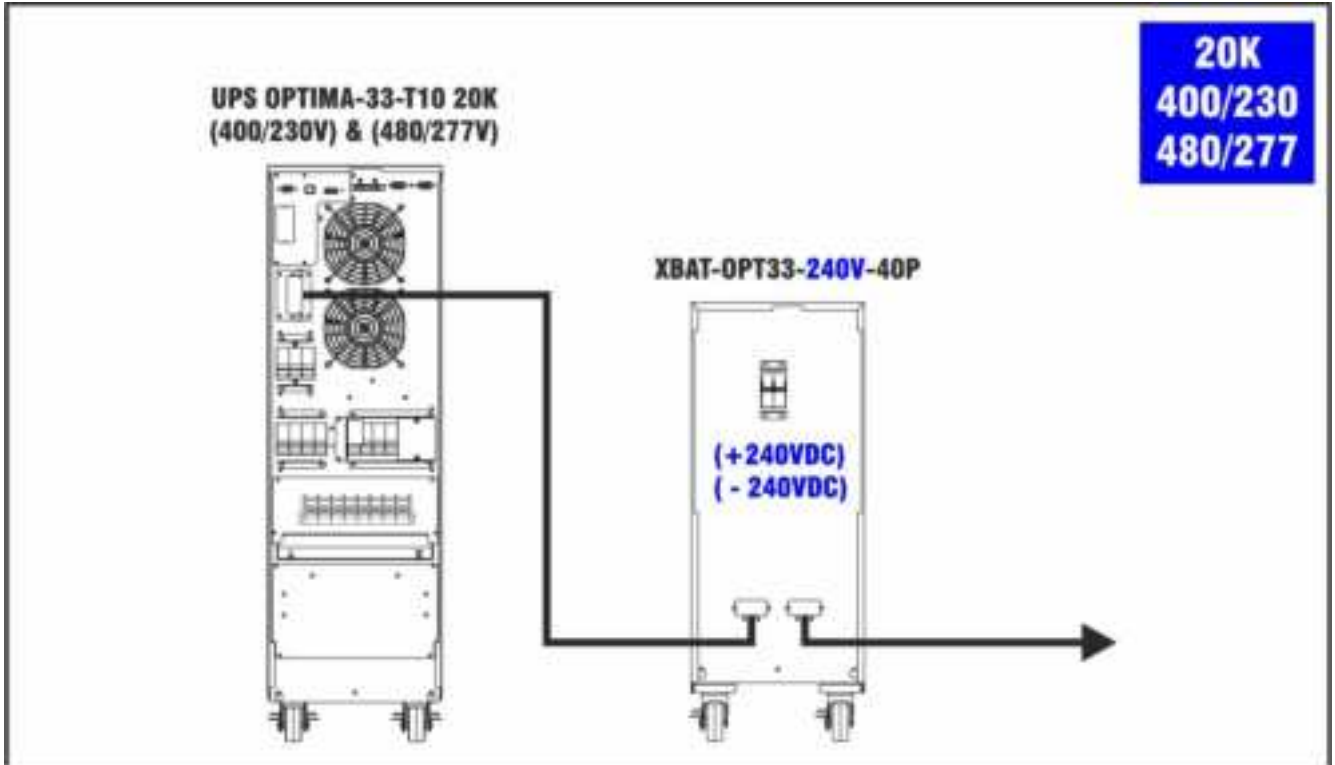

**EXTERNAL BATTERY CONNECTION:**

UPS 400/230V & 480/277V: 30K / 40K

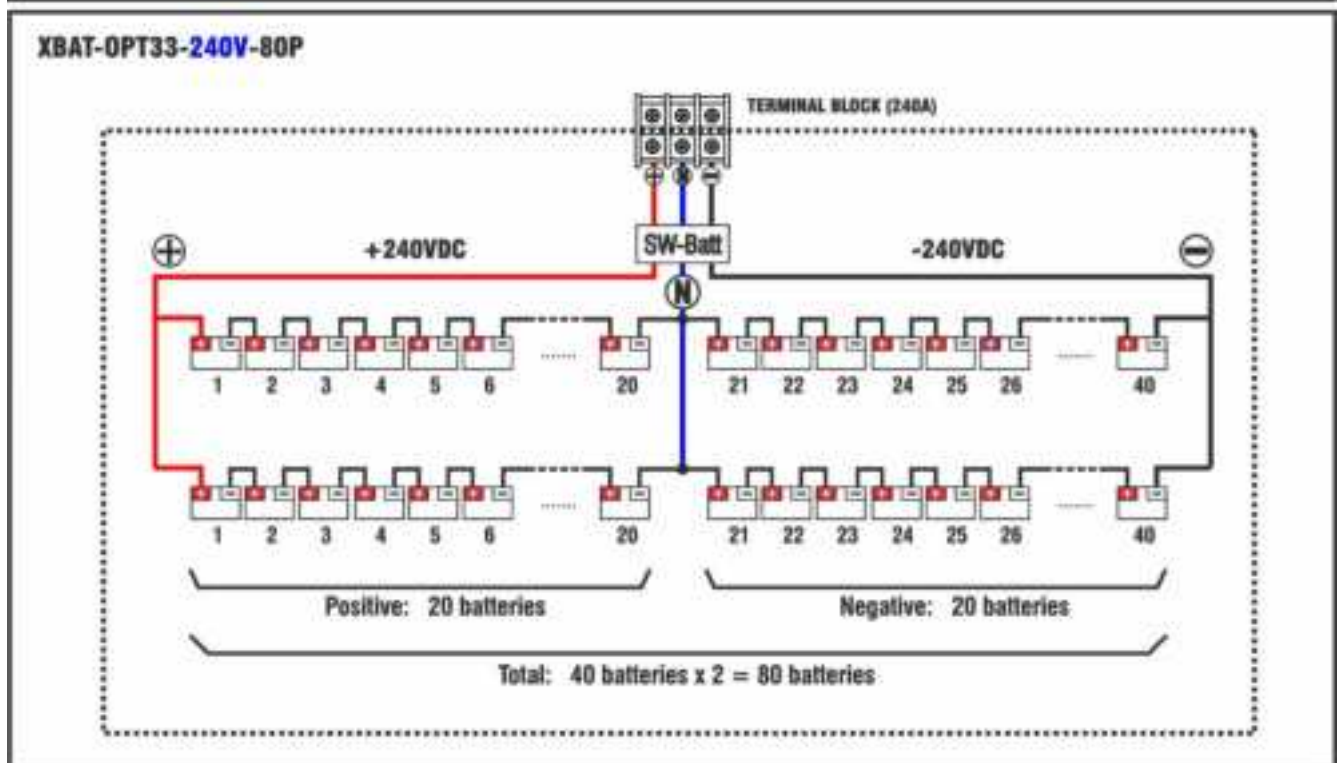
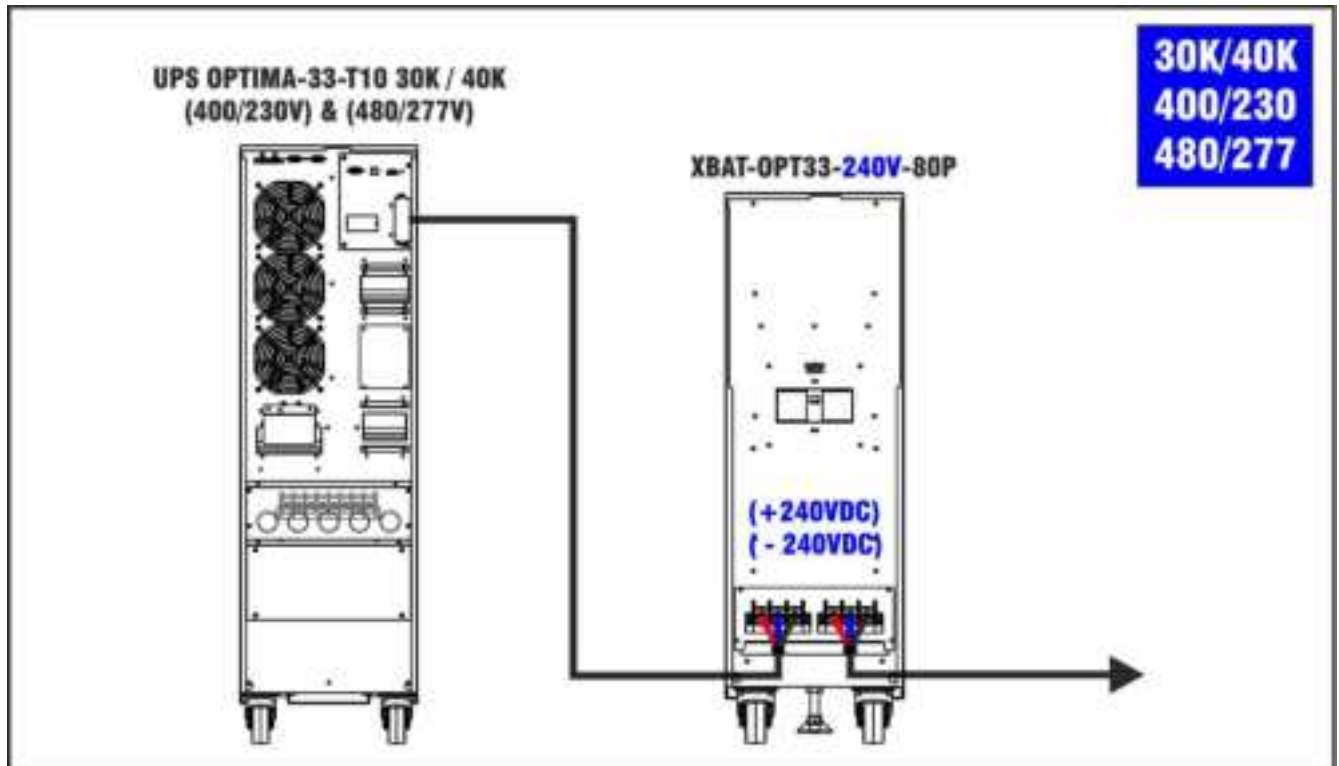

EXTERNAL BATTERY CONNECTION:

UPS 400/230V & 480/277V: 60K

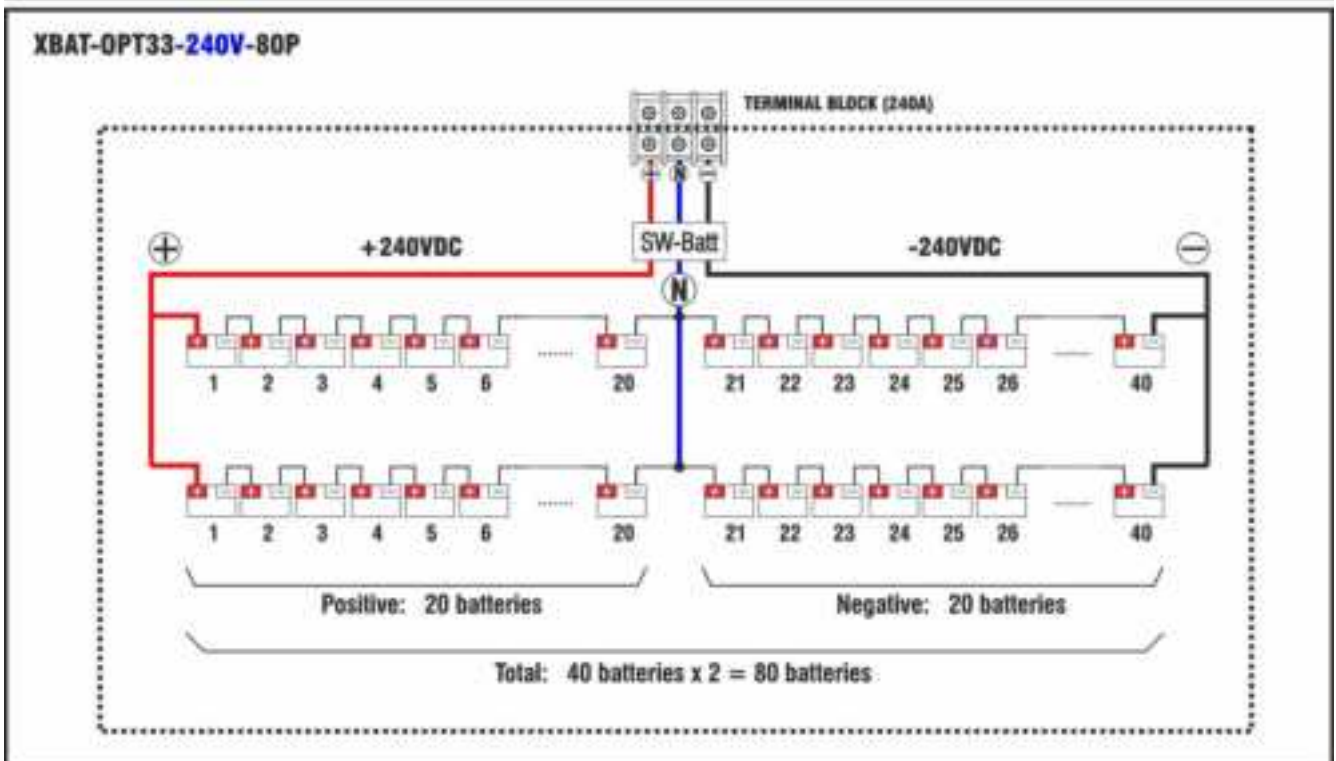
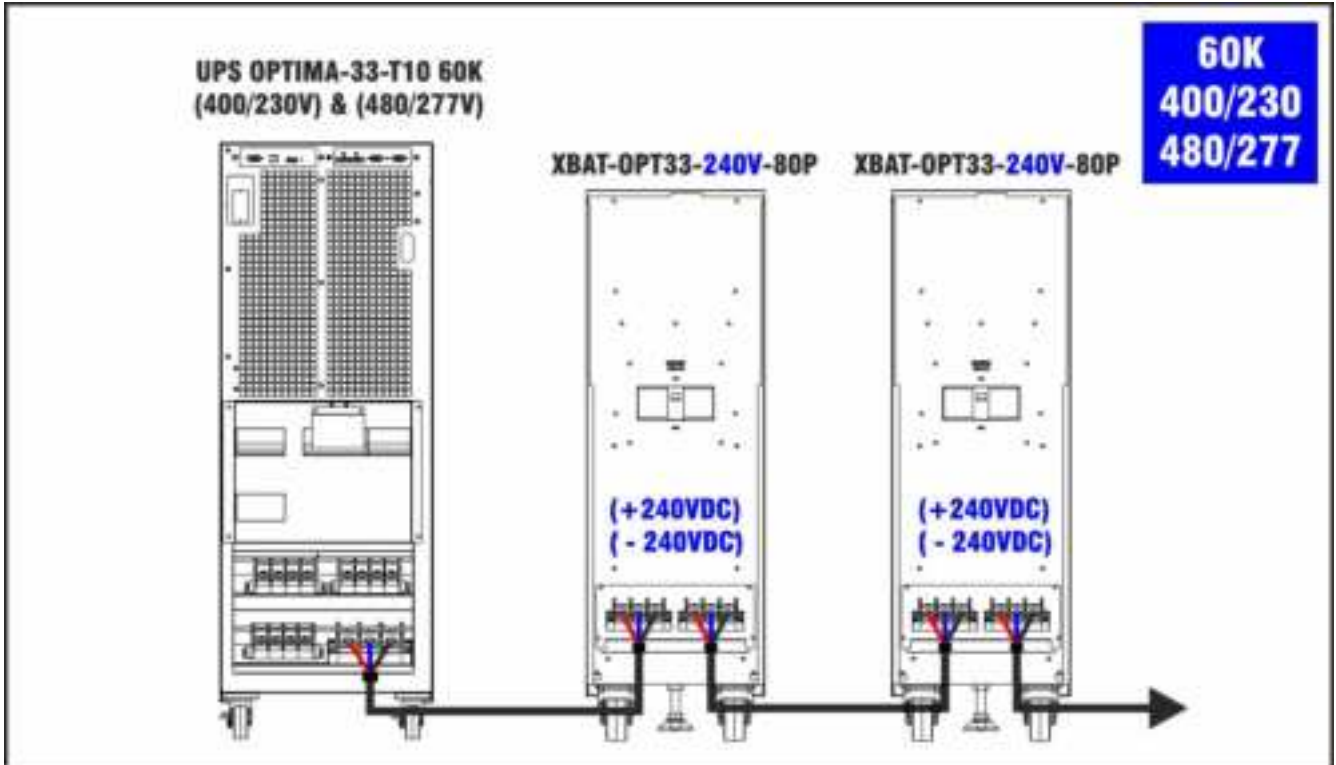

**EXTERNAL BATTERY CONNECTION:**

UPS 400/230V & 480/277V: 80K

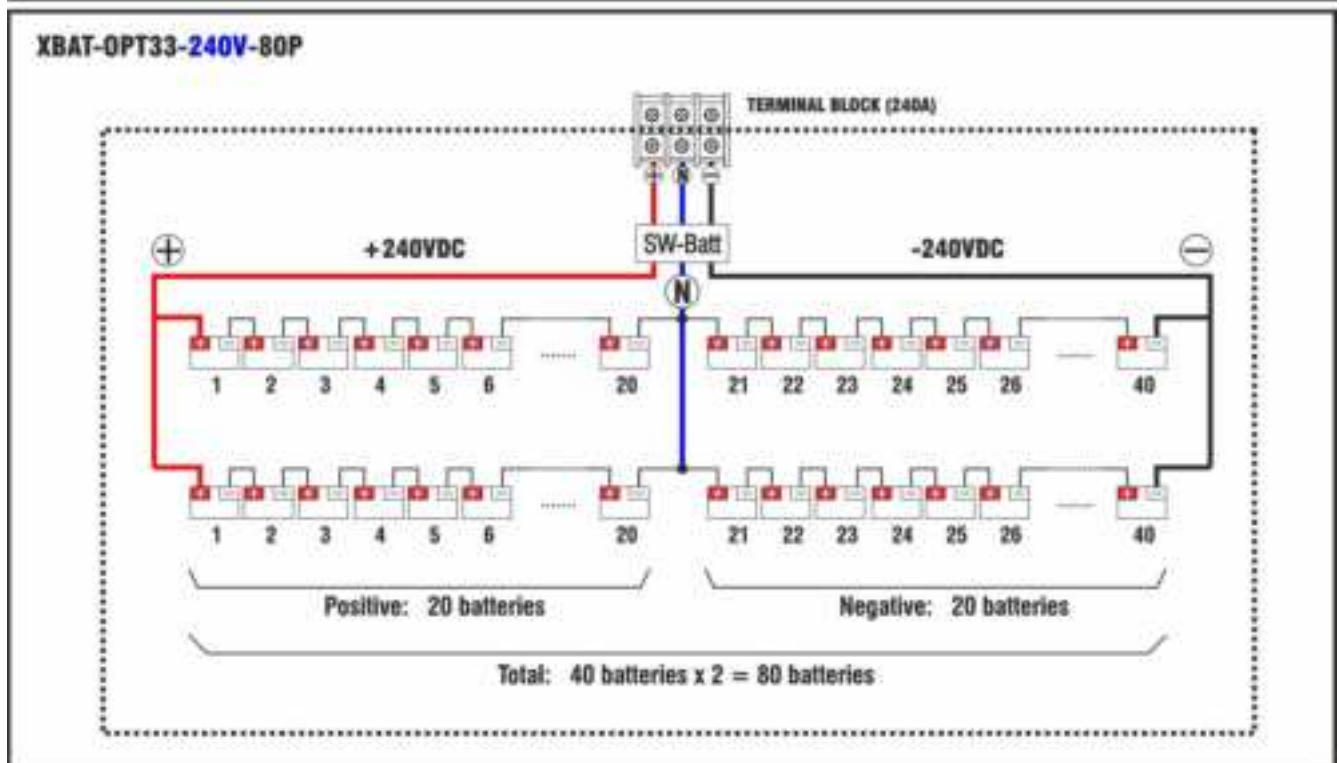
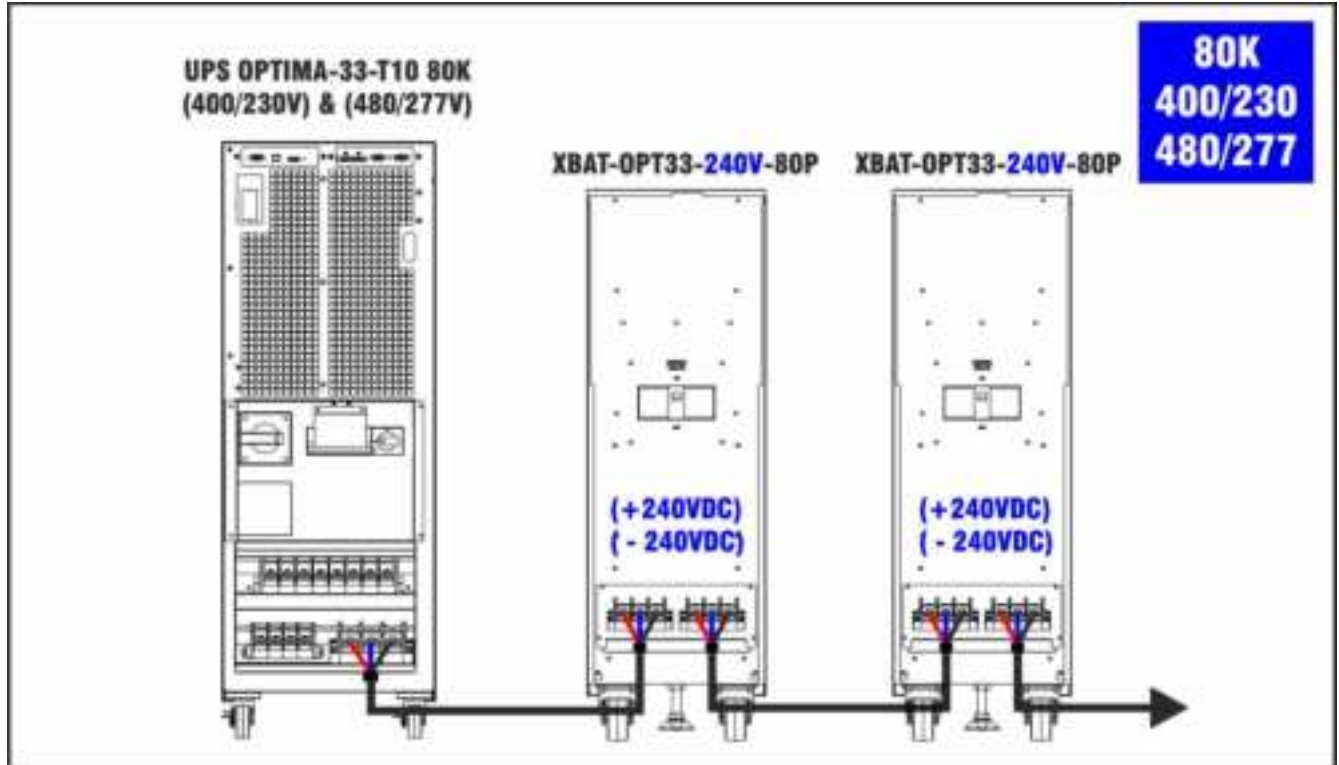

**7.- PARALLEL UPS WIRING – TERMINAL BLOCKS**

**GENERAL INFORMATION**

- Up to 3 units can be installed for parallel operation. This section describes connections for parallel systems.
- UPS operating in parallel must be configured and started up as explained in this manual.
- Any error during connection, configuration, or start up might cause permanent damages. Follow all instructions carefully.



- Make sure UPS is Off before start installation procedure.
- All wires to be connected (Including external batteries cables, if there are) must be power-off before starting any procedure.

Connecting UPS systems in parallel means connecting the main AC Line to the input of all the UPS units. All UPS outputs must be connected in parallel to one AC output to power the system to be protected.

We recommend each UPS to have an individual external Breaker both on its input and output. This allows maintenance work on any of the UPS without shutting down the system. It is advised to leave NEUTRAL lines between UPS out of the Breakers. Neutral is used as a reference point between UPS and should always be connected. Improper operation of individual Circuit Breaker could open one of the neutrals, leading to operational errors.

Additionally, it is mandatory to use Circuit Breakers both at the general input of the system and at its output.

The following figure shows the general wiring scheme for this UPS family, showing all recommended Circuit Breakers.

Further on in this section, the detailed connection between the UPS terminal blocks is shown in detail.

**AC INPUT:** Main AC Input Power Source

**R, S, T, N:** Input lines L1, L2, L3, and neutral

**U, V, W, N:** Input lines L1, L2, L3, and neutral

**BRK-IP:** Main AC input circuit breaker

**BRK-OP:** AC output circuit breaker

**SW-IP-1 / SW-IP-2 / SW-IP-3:** Individual input Breaker for each UPS

**SW-OP-1 / SW-OP-2 / SW-OP-3:** Individual output Breaker for each UPS

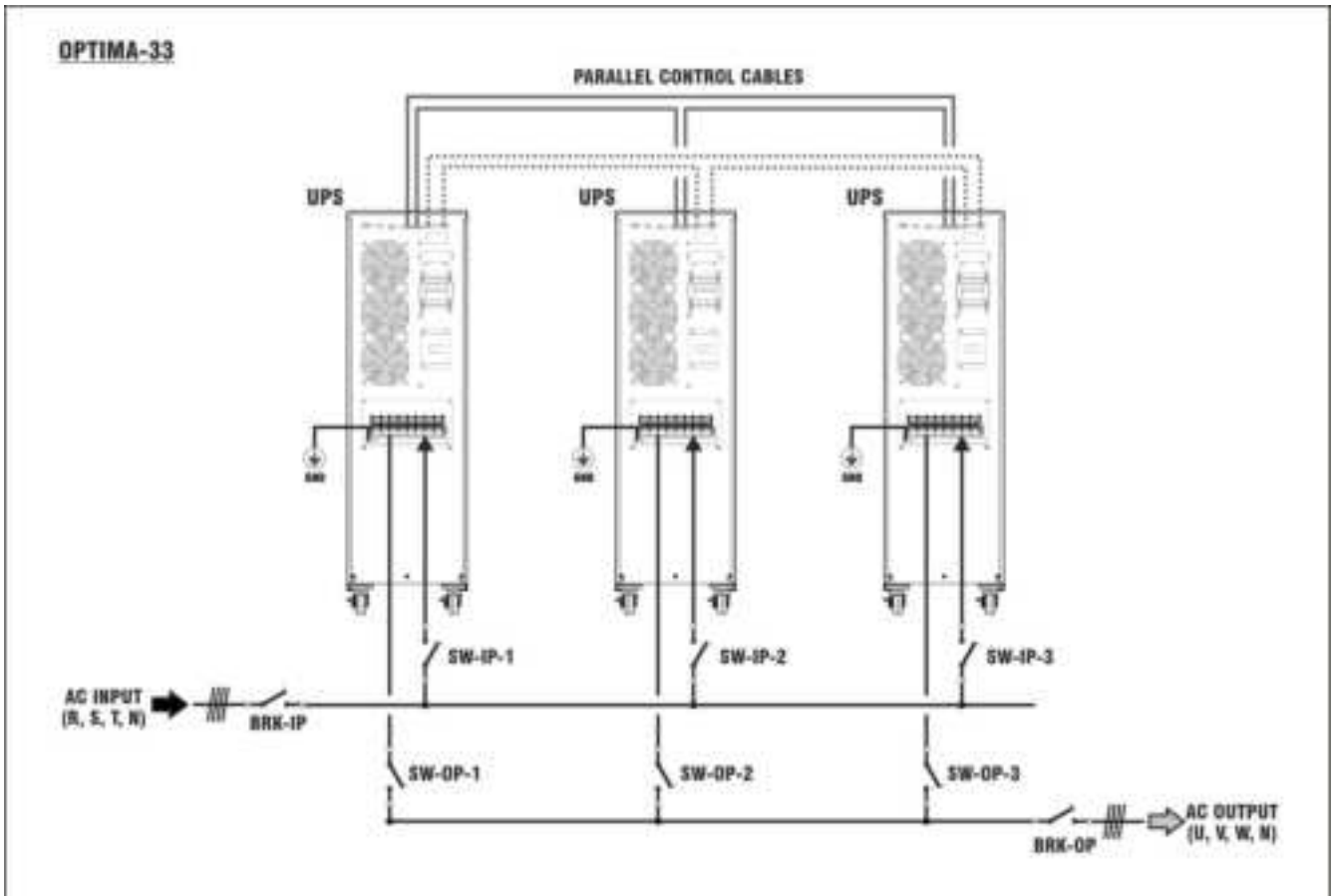

---

**AC LINES: CONNECTION PROCEDURES**

---



- \* **Make sure the UPS is Off before starting the installation.**
- \* **Remember to check all wires to be connected are not powered (including external batteries).**

**TERMINAL BLOCK PREPARATION**

Remove the safety plate that covers the terminal block as described in the section on individual UPS connections in this manual (section 6). Each line must be protected by a circuit breaker. For safety, the GROUND wires should be the first to be connected and the last to be disconnected from the UPS.

**IMPORTANT NOTE – EXTERNAL BATERIES:**

If external batteries are required, in a parallel UPS system, then each UPS must have its individual battery pack. UPS cannot share battery packs. Doing so will cause permanent damage to UPS.

---

**UPS INPUT AND OUTPUT CONNECTIONS**

---

**A) EARTH CABLES:**

First, connect the input and output Earth cables at the marked location on the chassis of the UPS. Connection points for Earth are usually provided at the sides of the connection terminal blocks or on the terminal block itself, depending on the model. EARTH cables should be the first to be connected and the last to be disconnected.

**B) AC INPUT CABLES:**

AC Input cables should come from a main Circuit Breaker from the Power Panel. These cables must be connected to individual magnetic circuit breakers before being connected to the UPS connection Terminal Block.

**C) AC OUTPUT CABLES:**

Ac Output cables from each UPS must be connected directly to individual Circuit Breakers. These individual magnetic circuit breakers must be connected to a main Circuit Breaker of bigger capacity, which can be connected to the equipment to be protected by the UPS System.

**D) BATTERY CABLES:**

If UPS have external batteries, then XBAT must be connected to the specific connector on the UPS.

**E) CONTROL CABLES FOR PARALLEL OPERATION:**

Connect the parallel and shared current cables according to the diagrams.

**THE FOLLOWING FIGURES, SHOW DETAILS OF CONNECTIONS BETWEEN UPS TERMINAL BLOCKS.**

**SCHEME SHOWS CONNECTIONS FOR 2 PARALLEL UPS. FOR 3 UPS PARALLEL CONNECTION, THE PHILOSOPHY IS THE SAME AS FOR 2 PARALLEL UPS.**

PARALLEL UPS: 2 UNITS

To connect 3 parallel UPS, follow the same scheme as for 2 UPS.

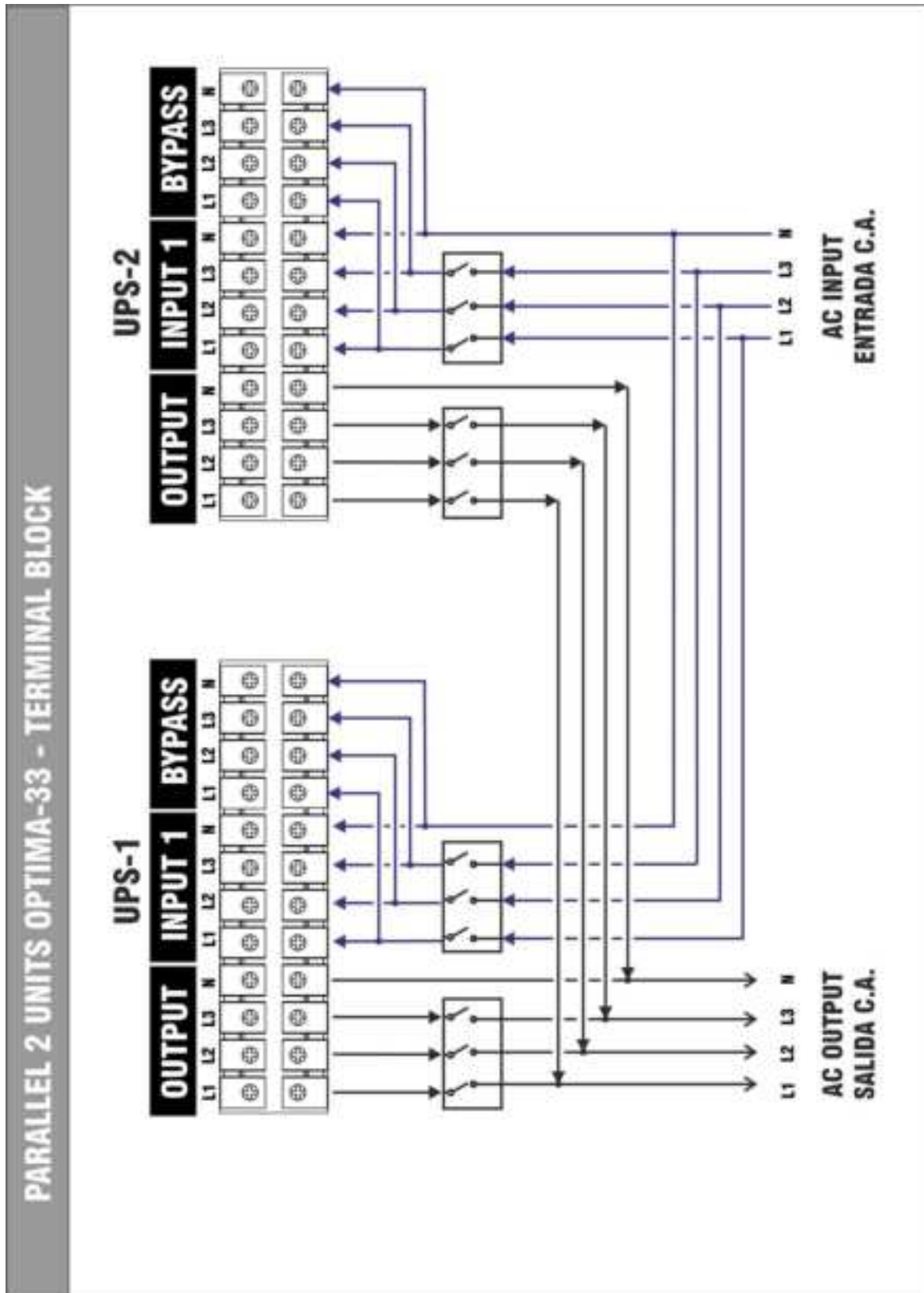

**PARALLEL UPS: PARALLEL CONTROL CABLES**

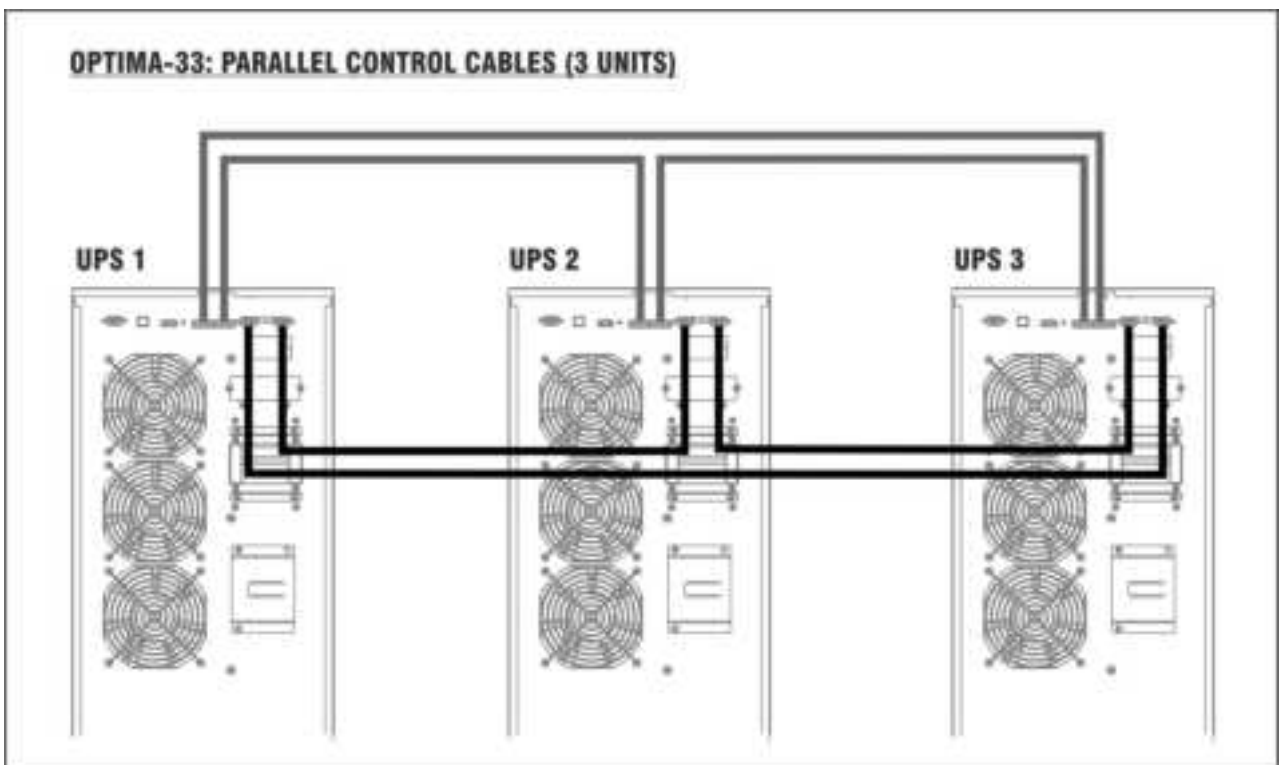
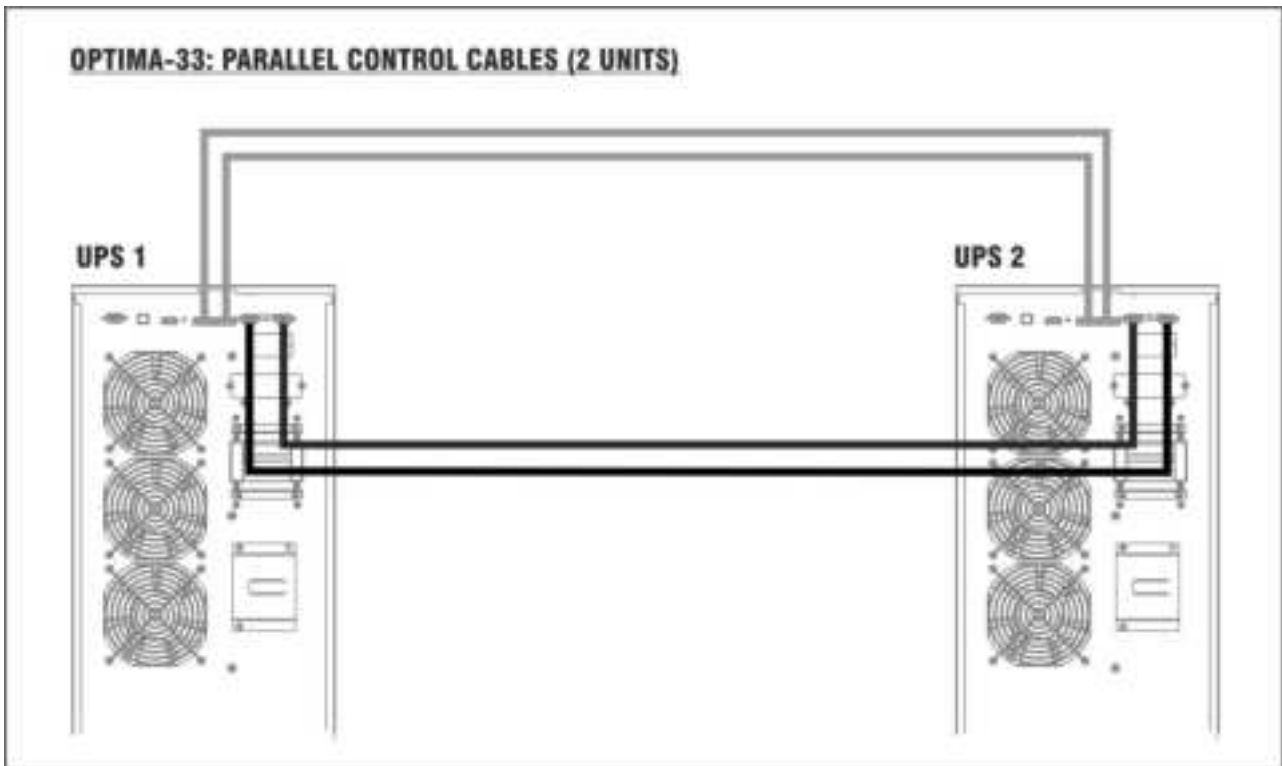

**8.- OPERATION INTERFACE**

**FRONTAL PANEL: 5 INCHES COLOR TOUCH SCREEN**

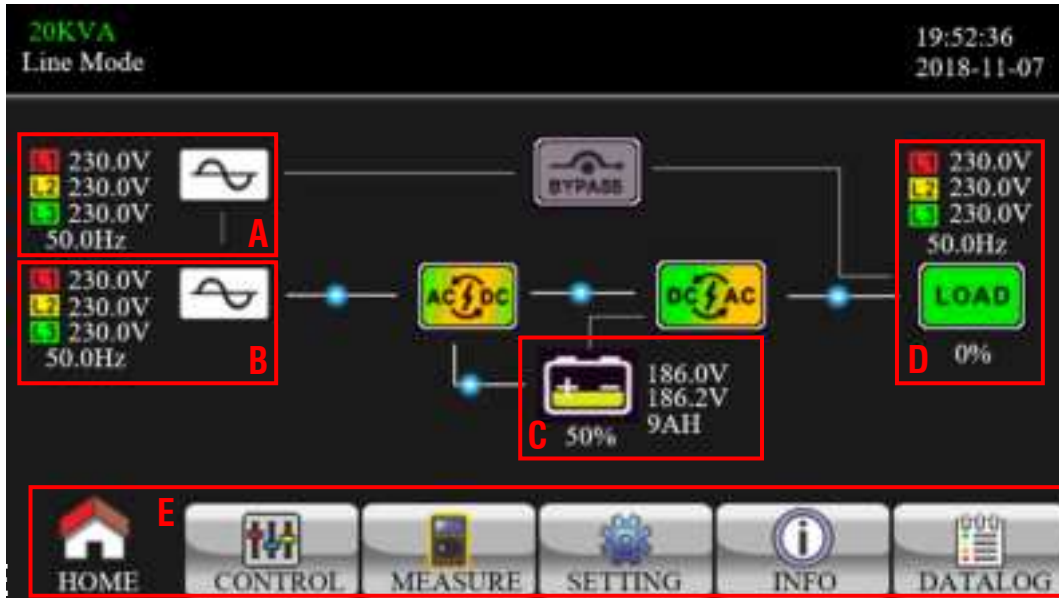

The image above shows the operation interface of the OPTIMA 33-T10 family, an efficient 5-inch color touch screen with a variety of relevant UPS information, divided into Operational Zones, identified as A, B, C, D, and E, and an efficient system of interactive menus, from which one can monitor, configure, and control the entire UPS operation in real time.

**OPERATIONAL ZONES OF THE SCREEN**

- **ZONE A:** Voltages and frequency of 3 phases of the Bypass line.
- **ZONE B:** Voltages and frequency of 3 phases of the main AC line.
- **ZONE C:** Battery voltage and remaining capacity.
- **ZONE D:** Voltages and frequency of UPS 3 output phases, as well as the consumption (percentage) connected to the output.
- **ZONE E:** Icons that provide access to the UPS menus.



- Access to the main screen from any point in the Menu.
- Access to the Control menu from where the UPS can be started and stopped.
- Access to the real-time measurement screens
- Access to the UPS parameter configuration menu
- Access to the UPS information screens
- Access to the UPS event report.

**OPERATIONAL ICONS**



- Electronic Internal Bypass
- Rectifier
- Inverter

UPS operation and setting is detailed explained in section 9.- UPS OPERATION AND CONFIGURATION

**9.- UPS OPERATION & CONFIGURATION**

This UPS family features a versatile and powerful touchscreen with icons to provide access to various UPS configuration and operation menus, as shown in the following figure:

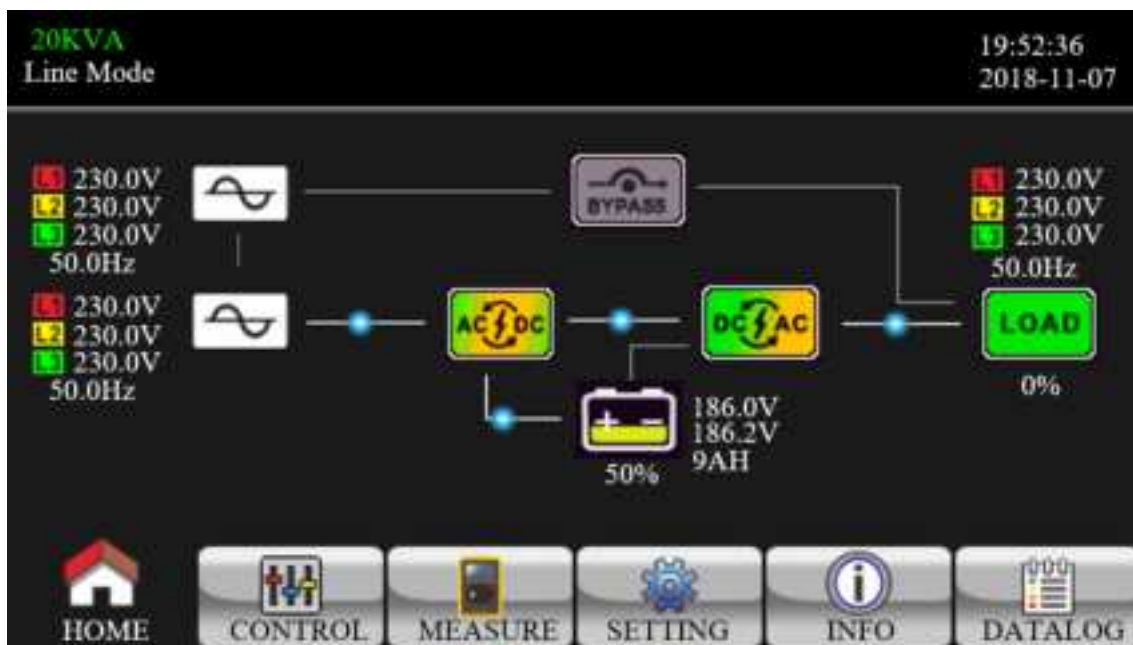

The UPS configuration and operation menu is structured as shown in the following diagram:



**MENUS DIAGRAM**

Below, the different operations that can be performed with this UPS, including configuration procedures, are described.

**POWERING UP THE UPS**

Having ensured that the UPS is properly installed (see startup and initialization section), it can be powered on. At this point, the screen will light up, indicating that it is performing self-diagnosis and initialization.

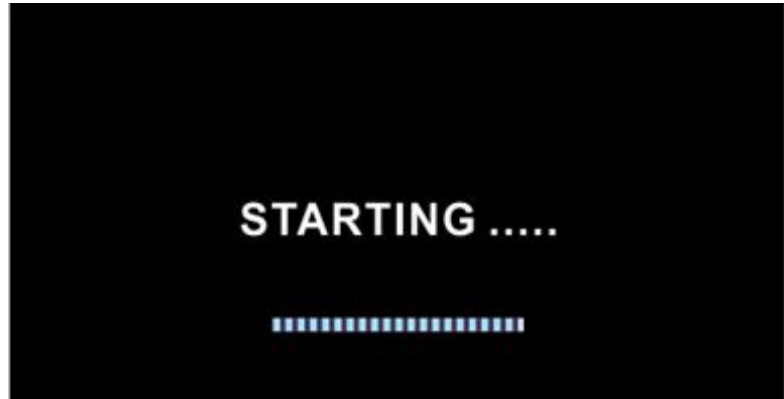

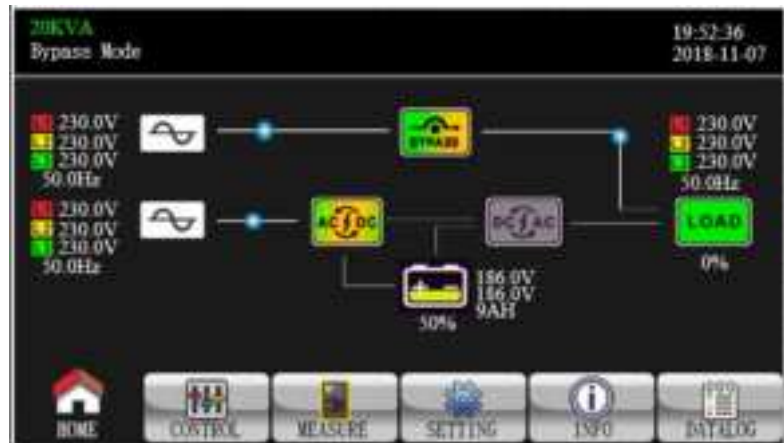

After a few seconds, the UPS should go to a state as shown on the right, indicating that everything is correct and waiting to be powered on.

By touching any of the icons in the bottom area of the screen, you will access the respective menu, which is described below



**CONTROL MENU:**

You can access this menu by tapping the icon  and tapping the icon  takes you back to the main screen from any other screen.

Below is the initial screen of this menu:



**PARAMETERS OF THIS MENU:**

**ON/OFF UPS**

**If UPS is Off:**

Confirmation Request (*Turn On UPS?*)

**YES:** Power on UPS and return to main screen

**NO:** Cancels and returns to the menu screen.

Returns to previous screen.



**If UPS is On:**

Confirmation Request (*Turn Off UPS?*)

**YES:** Power off UPS and return to main screen

**NO:** Cancels and returns to the menu screen.

Returns to previous screen.



**BATTERY TEST**

**If UPS is NOT testing Batteries:**

Confirmation Request (*BATT Test?*)

**YES:** The test begins, shows message “BATT Test” and upon completion, it will show the test result.

**NO:** Cancels and returns to the menu screen.

Returns to previous screen.



**If UPS is testing Batteries:**

Confirmation Request (*Cancel BATT Test?*)

**YES:** Interrupts the test.

**NO:** Keeps the test running.

Returns to previous screen.



## MUTE ALL

### If alarms are not Muted:

Confirmation Request (*Mute All?*)

**YES:** Mutes alarms. Icon  will be shown in top left corner of the screen.

**NO:** Cancels and returns to the menu screen.

 Returns to previous screen.



### If alarms are Muted:

Confirmation Request (*Cancel Mute All?*)

**YES:** Unmutes alarms. Icon  Will disappear from top left corner of the screen.

**NO:** Cancels and returns to the menu screen.

 Returns to previous screen.



## ON/OFF CHARGER

### If charger is off:

Confirmation Request (*Turn On Charger?*)

**YES:** Turns on the charger.

**NO:** Cancels and returns to the menu screen.

 Returns to previous screen.



### If charger is on:

Confirmation Request (*Turn Off Charger?*)

**YES:** Turns off the charger.

**NO:** Cancels and returns to the menu screen.

 Returns to previous screen.



**EXIT PARALLEL (See Safety Note)**

Confirmation Request (*Exit Parallel?*)

**YES:** Removes UPS from Parallel System, turns off output. UPS goes to STANDBY Mode.

**NO:** Cancels and returns to the menu screen.

Returns to previous screen.



If UPS is not in a parallel system and this command is attempted, the screen on the right will be displayed, indicating that it cannot be performed



**Safety Note:**

**When removing a UPS from a parallel system, the system will remain powered by remaining UPS, so there are several factors to consider. We strongly recommend that before carrying out this procedure, you review Section OPERATION: PARALLEL UPS in this manual to do it safely.**

**MEASUREMENT REPORT:**

You can access this menu by tapping the icon and tapping the icon takes you back to the main screen from any other screen.

As this page includes 3 screens, icons and can be used to scroll among them. Icon returns to previous screen. Below is the initial screen of this menu:



SCREEN: MEASUREMENT – PAGE 1 / 3

**DESCRIPTION OF LISTED VALUES – PAGE 1 / 3:**

**LINE VOL:** Real-time voltages of Input phases (L1, L2, & L3), Phase to Phase voltage (L1-L2: L12, L1-L3: L13. & L2-L3: L23) and Input Frequency.

**INVERTER VOL:** Real-time value of Inverter Voltage (L1, L2, & L3), Phase to Phase voltage (L1-L2: L12, L1-L3: L13. & L2-L3: L23) and its Frequency.

**BYPASS VOL:** Real-time voltages of Bypass phases (L1, L2, & L3), Phase to Phase voltage (L1-L2: L12, L1-L3: L13. & L2-L3: L23) and Input Frequency.

**OUTPUT VOL:** Real-time voltages of Output phases (L1, L2, & L3), Phase to Phase voltage (L1-L2: L12, L1-L3: L13. & L2-L3: L23) and Input Frequency.



**SCREEN: MEASUREMENT – PAGE 2 / 3**

**DESCRIPTION OF LISTED VALUES – PAGE 2 / 3:**

**OUTPUT W:** Output power in Watts on phases L1, L2, and L3.

**OUTPUT VA:** Output power in Volt-Amperes (VA) on phases L1, L2, and L3.

**OUTPUT W (%):** Percentage output power in Watts on phases L1, L2, and L3.

**OUTPUT VA (%):** Percentage output power in VA on phases L1, L2, and L3.

**TOTAL W (%):** Total percentage output power in Watts.

**TOTAL VA (%):** Total percentage output power in VA.

**BACKUP TIME:** Available backup in the UPS.

**BATT P VOL:** Voltage on the “P” line of the battery system.

**BATT N VOL:** Voltage on the “N” line of the battery system.

**BUS P VOL:** Voltage on the “P” line of the UPS internal bus.

**BUS N VOL:** Voltage on the “N” line of the UPS internal bus.

**CHARG CURR:** Charger current.

**DISCHG CURR:** Battery discharge current.

**TEMP 1:** Temperature on Phase L1.

**TEMP 2:** Temperature on Phase L2.

**TEMP 3:** Temperature on Phase L3.





INPUT W		INPUT VA		INPUT CURR		INPUT PF	
L1:	4W	L1:	46VA	L1:	0.3A	L1:	0.08
L2:	4W	L2:	46VA	L2:	0.3A	L2:	0.08
L3:	4W	L3:	46VA	L3:	0.3A	L3:	0.08
INPUT W(%)		INPUT VA(%)		OUTPUT CURR		OUTPUT PF	
L1:	0%	L1:	0%	L1:	0.3A	L1:	0.08
L2:	0%	L2:	0%	L2:	0.3A	L2:	0.08
L3:	0%	L3:	0%	L3:	0.3A	L3:	0.08
TOTAL W(%)		TOTAL VA(%)					
0%		0%					

**SCREEN: MEASUREMENT – PAGE 3 / 3**

**DESCRIPTION OF LISTED VALUES – PAGE 3 / 3:**

- INPUT W:** Input power in Watts on phases L1, L2, and L3.
- INPUT VA:** Input power in Volt-Amperes (VA) on phases L1, L2, and L3.
- INPUT W (%):** Percentage Input power in Watts on phases L1, L2, and L3.
- INPUT VA (%):** Percentage Input power in VA on phases L1, L2, and L3.
- TOTAL W (%):** Total percentage Input power in Watts.
- TOTAL VA (%):** Total percentage Input power in VA.
- INPUT CURR:** Real-time current in input phases L1, L2, and L3.
- OUTPUT CURR:** Real-time current in output phases L1, L2, and L3.
- INPUT PF:** UPS Input power factor.
- OUTPUT PF:** Power factor connected to the UPS output.

**SETTINGS MENU:**

You can access this menu by tapping the icon  and tapping the icon  takes you back to the main screen from any screen. As this page includes several screens, icons  and  can be used to scroll among them. Icon  returns to previous screen. Below is the initial screen of this menu:



- **GENERAL:** UPS basic information can be configured here, not related with operation parameters.
- **ADVANCE:** This section is to configure UPS operative parameters; Therefore, a password is required to access, and there are two levels of access with different scopes: User and SERVICE, both of which will be explained later.

**SETTING → GENERAL**



**SCREEN: SETTING → GENERAL – PAGE 1 / 2**

**GENERAL MENU PARAMETERS – PAGE 1 / 2:**

**LANGUAGE:** Sets UPS Screen language. There are three available options: English (Default), Simplified Chinese, and Traditional Chinese.

**INPUT SOURCE:** Sets the UPS power supply: AC Line (**Default**) or **Generator**, which enlarges input frequency range to 40 - 70 Hz.

**CONTACT:** Name of service contact person, Max. Length: 18 characters.

**PHONE:** Service phone number, Max Length: 14 characters. It only admits numbers and characters + and -.

**MAIL:** Service Email, Max Length: 36 characters.



**SCREEN: SETTING → GENERAL – PAGE 2 / 2**

**GENERAL MENU PARAMETERS – PAGE 2 / 2:**

**AUDIO ALARM:** This menu allows enabling or disabling Mute for 2 types of audible alarms. When Mute is enabled, the icon  appears in the upper right corner of the screen, and the alarm will not be heard if the event that triggers it occurs. These are the alarms that can be silenced:

- All Mute: If Enabled, ALL failure and Warning sound alarms will be muted. Default: Disable.
- Mode Mute: If enabled, Operation mode change Warning will mute. Default: Disable.

**SETTING → ADVANCE→USER**



**SCREEN: SETTING → ADVANCE**

From this screen, 2 different ADVANCE Menu levels can be reached, according to entered password. Below there is an explanation to access **ADVANCE→USER** Menu:

If password **0000** is entered:

Access to **CONFIGURACION→ADVANCE→USER** Menu

 Returns to previous screen.





If wrong password is entered:

Notification message (**Password Error!!**), password must be entered again.

 Returns to previous screen.



**SETTING → ADVANCE→USER**

Remember icon  takes you back to the main screen from any other screen. Icon  returns to previous screen. Below is the initial screen of this menu:



**SCREEN: SETTING → ADVANCE→USER**

From this Screen, 3 submenus are accessible: ELECTRONIC, BATTERY, and MISCELANEOUS, explained as follows:

**SETTING → ADVANCE→USER → ELECTRONIC**



**SCREEN: SETTING→ ADVANCE→USER → ELECTRONIC – PAGE 1 / 2**

**PARAMETERS IN THIS MENU:**

**OUTPUT VOL:** Sets UPS nominal voltage. Available options:

- 400/230V Models: 208V, 220V, 230V, 240V
- 208/120V Models: 120V, 127V

**OUTPUT FRE:** Sets UPS nominal frequency. Available options are: 50Hz & 60Hz.

**CVCF MODE:**

- Enable: Enables the Frequency Conversion Mode, which will be set to the value configured in the previous parameter, as long as the input frequency remains between 40Hz and 70Hz.
- Disable: Factory default setting. Disables the Frequency Conversion Mode. The UPS frequency will synchronize with the Bypass line, within the valid range, which is 45 to 55 Hz for 50Hz systems and 55 to 65 Hz for 60Hz systems.

**- IMPORTANT NOTES ABOUT FREQUENCY CONVERSION FUNCTION:**

- If Frequency Conversion function is enabled to generate an output with a frequency different from the input frequency, the UPS's bypass mode will be automatically disabled. However, each time you turn on the UPS, there will be a 2-second transient period during which the UPS will operate in bypass mode, passing power from input to output.
- If the UPS triggers input circuit breaker when being powered, UPS might be configured to operate at a different frequency than the system it has been connected to. In this case, you should follow this procedure:

Turn on the UPS by pressing the button  next to the screen.

When UPS screen is on in Battery Mode, go to **SETTING→ADVANCE→USER→Electronic** menu and review the parameters:

- **CVCF MODE:** If you do not require this function, set it to “Disable”. Doing so, UPS will synchronize with the line frequency.
- **OUTPUT FRE:** If you need the **CVCF MODE**, adjust the **OUTPUT FRE** parameter to the same value as the line frequency. Turn off the UPS using the standard procedure and repeat the Startup procedure.
- When CVCF function is enabled, maximum UPS output power is reduced by 40%. For example: for a 10KVA UPS max. output power drops to 6KVA.

**BYPASS FORBID:** UPS Bypass disabled.

- Enable: This option disables Bypass, and it cannot be enabled under any circumstances
- Disable: This option leaves Bypass enabled allowing it to function according to UPS configuration. This is the factory default value.

**NEUTRAL LINE CHECK:** Neutral Loss Detection Function.

- Disable: This option disables this function. The UPS will not be able to detect the loss of the neutral line connection.
- Auto: Activates neutral loss detection. If a neutral loss is detected, an alarm is generated, and if the UPS is turned on, it will switch to Battery Mode. Upon the recovery of the neutral, the alarm is turned off, and UPS automatically returns to Normal Mode.
- Check: Activates neutral loss detection during the UPS startup. If a neutral loss is detected, an alarm is generated, and if the UPS is turned on, it will switch to Battery Mode. Upon recovery of neutral line, the alarm does NOT turn off automatically, and UPS does not return to Normal Mode automatically.

**ISO COMPENSATION:** Allows increasing the UPS output voltage to compensate for the load of an isolation transformer connected UPS output.



SCREEN: SETTING → ADVANCE → USER → ELECTRONIC – PAGE 2 / 2

## PARAMETERS IN THIS MENU:

**Bypass UPS off:** Bypass Mode When UPS Is Turned Off. This setting only applies when the “Bypass forbid” parameter is disabled.

- Enable: Choosing this option activates Bypass Mode when the UPS is turned off. Factory default setting.
- Disable: This option disables Bypass, so when the UPS is turned off manually, output also turns off

**Bypass Voltage Range:** Sets valid voltage range for Bypass Mode.

- 400/230V Models: Low Voltage Limit Range: 176V to 209V / High voltage Limit Range: 231V to 264V
- 208/120V Models: Low Voltage Limit Range: 96V to 110V / High voltage Limit Range: 130V to 146V

**FRE Range:** Sets valid frequency range for Bypass Mode.

- 50Hz Systems: 46Hz to 54Hz.
- 60Hz Systems: 56Hz to 64Hz.

**ECO Mode:** “Enable”: Enables ECO Mode. “Disable”: Disables ECO Mode. Factory setting: “Disable”.

**ECO VOL Range:** Sets valid voltage range for Bypass ECO Mode.

- Low Limit: From -5V up to -11V below nominal voltage. Factory setting: -5V below nominal voltage.
- High Limit: From +5V up to +11V over nominal voltage. Factory setting: +5V over nominal voltage.

**ECO FRE Range:** Sets valid frequency range for ECO Mode

- 50Hz Systems: 46Hz to 54Hz.
- 60Hz Systems: 56Hz to 64Hz.

**SETTING → ADVANCE → USER → BATTERY**



**SCREEN: SETTING → ADVANCE → USER → BATTERY**

**PARAMETERS IN THIS MENU:**

**BATT Warning VOL:** Batteries voltages that trigger alarms.

- HIGH: High battery voltage alarm value. Available range: 14.0V to 15.0V. Factory setting: 14.4V
- LOW: Low battery voltage alarm value. Available range: 10.1V to 14.0V. This parameter must be higher than next one, **Shutdown VOL**. Factory setting: 11.4V

**Shutdown VOL:** If battery voltage drops under configured value, UPS shuts down. Available range: 10V to 12V. Factory setting: 10.7V.

**BATT Age:** Battery lifespan.

**BATT Parameters:**

- Battery AH: Battery Capacity in AH.

**SETTING → ADVANCE → USER → MISCELLANEOUS**



**SCREEN: SETTING → ADVANCE → USER → MISCELLANEOUS**

**PARAMETERS IN THIS MENU:**

**Auto Restart:** After UPS shut down due to deep battery discharge, Auto-Restart Function allows UPS can automatically turn on when the electrical line is restored and return to Normal Mode (Online Mode). Available options:

- Enable: Factory setting. Enables this function.
- Disable: This option enables Auto Restart.

**Shutdown Delay:** UPS shuts down after the number of minutes entered in this field. Countdown starts upon confirming the command.

**Restore Delay:** After the shutdown from the previous command, UPS will restart after the number of minutes entered in this field.

**New Password:** This function changes the password to access **SETTING → ADVANCE → USER** Menu.

**SETTING → ADVANCE → SERVICE**

This menu is reserved for special maintenance tasks because configuration errors can cause damage to the UPS, so access to this menu is restricted.



**SCREEN: SETTING → ADVANCE**

From this screen, you can access the two levels of ADVANCE menus, depending on the entered key. Below is the description of access to **ADVANCE → SERVICE** menu:

The key for this level is reserved for special maintenance tasks and is not public domain.

For access to the SERVICE MENU, please contact **Xmart UPS** technical department or visit our website: [www.xmart-ups.com](http://www.xmart-ups.com).

With the correct password, you will have access to

**SETTING → ADVANCE → SERVICE** menu.

 Returns to previous screen.



If wrong password is entered,

you will receive a notification message: **Password Error!!**.

 Returns to previous screen.



**SETTING → ADVANCE→SERVICE**

Remember icon takes you back to the main screen from any other screen. Since this menu contains multiple screens, you can use icons and (where available) to scroll between them. Icon returns to previous screen.

In this menu, there are 9 sub-menus distributed across 2 screens, as shown in the following figures:



**SCREEN: SETTING → ADVANCE→SERVICE – PAGE 1 / 2**



**SCREEN: SETTING → ADVANCE→SERVICE – PAGE 2 / 2**

Next, the 9 available sub-menus are explained:

**SETTING → ADVANCE→ SERVICE → FIRST SCREEN – SYS PARAMETERS**



**SCREEN: SETTING → ADVANCE→SERVICE → SYS PARAMETERS – PAGE 1 / 2**

**PARAMETERS IN THIS MENU:**

**Mode Name:** Name of UPS model.

**Serial Number:** UPS Serial Number.

**Manufacturer:** Manufacturer

**Charger Number:** Number of Battery Chargers in UPS.

**NOTE:** If this parameter is changed, UPS must be restarted.

**Max Charge CURR:** Max. batteries charge current.

- Options for 1 battery charger: 1A, 2A, 3A, 4A, 5A, 6A, 7A, 8A, 9A, 10A, 11A, 12A.
- Options for 2 battery chargers: 2A, 4A, 6A, 8A, 10A, 12A, 14A, 16A, 18A, 20A, 22A, 24A

**BATT Number:** Number of batteries connected in series on the positive or negative side of the battery bank.

- 400/230V Model: Range:16 to 20. Factory setting: 20. Except 10K Model, which has same configuration as 208/120V UPS, see next line.
- 208/120V Models: Range:8 to 10. Factory setting: 10.



**SCREEN: SETTING → ADVANCE→SERVICE → SYS PARAMETERS – PAGE 2 / 2**

**Float VOL:** Battery charging voltage setting for float (maintenance) phase of the charger. Factory setting: 13.6V.

**UPS Type:** There are two available options: HV (220V and similar) and LV (120V and similar). Changes are only permitted to qualified technicians and require a UPS restart after setting.

**Power Setting:** Output power factor, in percentage. Factory setting: 100%.

**Output setting:** Number of Input & Output Phases. Available options: 3-3 (Three-Phase Input-Three-Phase Output) and 3-1 (Three-Phase Input-Single-Phase Output). For single-phase models (Single-Phase Input-Single-Phase Output), 3-1 option must be used, with all 3 input phases connected to each other. This change requires a UPS restart.

**NOTE: PROCEDURE FOR THIS SETTING IS RESERVED FOR HIGHLY QUALIFIED PERSONNEL. SETTING AN OUTPUT DIFFERENT FROM FACTORY WITHOUT PROPER PREPARATION CAN PERMANENTLY DAMAGE THE UPS, WHICH IS NOT COVERED BY THE WARRANTY.**

**Customer Code:** Reserved for future use in the dynamic key system.

**DynamicPassword:** Reserved for future use in the dynamic key system.

**SETTING → ADVANCE→ SERVICE → FIRST SCREEN – INSTALL INFO**



**SCREEN: SETTING → ADVANCE→SERVICE → INSTALL INFO**

**PARAMETERS IN THIS MENU:**

**Sys Install Date:** Register the UPS installation date here.

**BATT Install Date:** Register the Batteries installation date here.

**Date/Time:** System Date and Time Setting. Format is: YYYY-MM-DD HH:MM:SS.

**SETTING → ADVANCE → SERVICE → FIRST SCREEN – VOL CALI**



SCREEN: SETTING → ADVANCE → SERVICE → VOL CALI – PAGE 1 / 3

**PARAMETERS IN THIS MENU:**

**Bus VOL:** Voltage calibration of the two lines of the internal UPS bus (P and N). Setting procedure:

- Tap on the percentage of the value to be adjusted, and setting icon will appear as seen on the right.
- Up key increases the value by 0.1%, and down key decreases it by 0.1%.
- When desired value is reached, tap the "OK" key to confirm the operation.

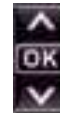

**BATT VOL:** Voltage calibration of the batteries. For both battery lines (P and N). Setting procedure:

- Tap on the percentage of the value to be adjusted, and setting icon will appear as seen on the right.
- Up key increases the value by 0.1%, and down key decreases it by 0.1%.
- When desired value is reached, tap the "OK" key to confirm the operation.

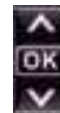

SCREEN: SETTING → ADVANCE → SERVICE → VOL CALI – PAGE 2 / 3

**PARAMETERS IN THIS MENU:**

**Line VOL:** Voltage calibration of input phases (L1, L2, & L3). Setting procedure:

- Tap on the percentage of the value to be adjusted, and setting icon will appear as seen on the right.
- Up key increases the value by 0.1%, and down key decreases it by 0.1%.
- When desired value is reached, tap the "OK" key to confirm the operation.

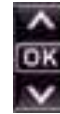

**Output VOL:** Voltage calibration of Output phases (L1, L2, & L3). Setting procedure:

- Tap on the percentage of the value to be adjusted, and setting icon will appear as seen on the right.
- Up key increases the value by 0.1%, and down key decreases it by 0.1%.
- When desired value is reached, tap the "OK" key to confirm the operation.

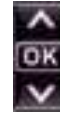

**SCREEN: SETTING → ADVANCE → SERVICE → VOL CALI – PAGE 3 / 3**

**PARAMETERS IN THIS MENU:**

**Inverter VOL:** Voltage calibration of Inverter phases (L1, L2, & L3). Setting procedure:

- Tap on the percentage of the value to be adjusted, and setting icon will appear as seen on the right.
- Up key increases the value by 0.1%, and down key decreases it by 0.1%.
- When desired value is reached, tap the "OK" key to confirm the operation.

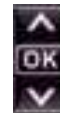

**Bypass VOL:** Voltage calibration of Inverter phases (L1, L2, & L3). Setting procedure:

- Tap on the percentage of the value to be adjusted, and setting icon will appear as seen on the right.
- Up key increases the value by 0.1%, and down key decreases it by 0.1%.
- When desired value is reached, tap the "OK" key to confirm the operation.

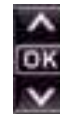

**SETTING → ADVANCE → SERVICE → CURR CALI**



**SCREEN: SETTING → ADVANCE → SERVICE → CURR CALI**

**PARAMETROS DE ESTE MENU:**

**Output CURR:** Current calibration of Output phases (L1, L2, & L3). Setting procedure:

- Tap on the percentage of the value to be adjusted, and setting icon will appear as seen on the right.
- Up key increases the value by 0.1%, and down key decreases it by 0.1%.
- When desired value is reached, tap the "OK" key to confirm the operation.

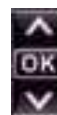

**SETTING → ADVANCE → SERVICE → INITIAL**



**SCREEN: SETTING → ADVANCE → SERVICE → INITIAL**

Initialization Menu. From here, many UPS parameters can be reset to their factory values, as well as data from the log can be deleted.

**PARAMETERS IN THIS MENU:**

**DATA LOG:** Deletes UPS event log.

Confirmation asked: **Initial the Datalog?**

**YES:** Deletes UPS event log.

**NO:** Cancels and returns to previous screen.

 Returns to previous screen.



**PARAMETERS:** Restores the operational parameters of the UPS to factory values.

Confirmation asked: **Initial the Parameters?**

**YES:** Restores initial UPS operating parameters, from factory.

**NO:** Cancels and returns to previous screen.

 Returns to previous screen.

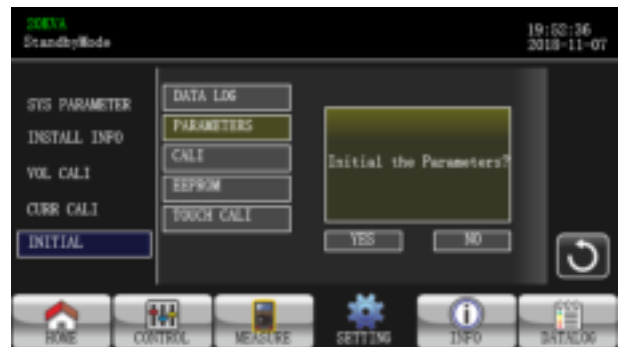

**CALI:** Restores calibration parameters of the UPS to factory values.

Confirmation asked: **Initial the CALI?**

**YES:** Restores initial UPS calibration parameters, from factory.

**NO:** Cancels and returns to previous screen.

 Cancels and returns to previous screen.



**EEPROM:** Deletes UPS EEPROM memory content.

Confirmation asked: **Initial the EEPROM?**

**YES:** Restores initial **EEPROM** content, from factory.

**NO:** Cancels and returns to previous screen.

 Cancels and returns to previous screen.



**TOUCH CALI:** Recalibrates UPS Touch Screen.

Confirmation asked: **Initial the TOUCH?**

**YES:** Erases the UPS Touch Screen calibration to start a new recalibration

**NO:** Cancels and returns to previous screen.

Returns to previous screen.



Once the recalibration is confirmed, UPS will display an empty screen as shown on the right. Pop-up white cross should be touched to perform a new screen calibration.



**SETTING → ADVANCE → SERVICE → SECOND SCREEN – ELECTRONIC**



**SCREEN: SETTING → ADVANCE → SERVICE → ELECTRONIC – PAGE 1 / 2**

**PARAMETERS IN THIS MENU:**

**OUTPUT VOL:** Sets UPS nominal voltage. Available options:

- 400/230V Models: 208V, 220V, 230V, 240V
- 208/120V Models: 120V, 127V

**OUTPUT FRE:** Sets UPS nominal frequency. Available options are: 50Hz & 60Hz.

**CVCF MODE:**

- Enable: Enables the Frequency Conversion Mode, which will be set to the value configured in the previous parameter, as long as the input frequency remains between 40Hz and 70Hz.
- Disable: Factory default setting. Disables the Frequency Conversion Mode. The UPS frequency will synchronize with the Bypass line, within the valid range, which is 45 to 55 Hz for 50Hz systems and 55 to 65 Hz for 60Hz systems.

**- IMPORTANT NOTES ABOUT FREQUENCY CONVERSION FUNCTION:**

- If Frequency Conversion function is enabled to generate an output with a frequency different from the input frequency, the UPS's bypass mode will be automatically disabled. However, each time you turn on the UPS, there will be a 2-second transient period during which the UPS will operate in bypass mode, passing power from input to output.
- If the UPS triggers input circuit breaker when being powered, UPS might be configured to operate at a different frequency than the system it has been connected to. In this case, you should follow this procedure:

Turn on the UPS by pressing the button  next to the screen.

When UPS screen is on in Battery Mode, go to **SETTING→ADVANCE→USER→Electronic** menu and review the parameters:

- **CVCF MODE**: If you do not require this function, set it to **"Disable"**. Doing so, UPS will synchronize with the line frequency.
  - **OUTPUT FRE**: If you need the **CVCF MODE**, adjust the **OUTPUT FRE** parameter to the same value as the line frequency.
- Turn off the UPS using the standard procedure and repeat the Startup procedure.

- When **CVCF** function is enabled, maximum UPS output power is reduced by 40%. For example: for a 10KVA UPS max. output power drops to 6KVA.

**BYPASS FORBID**: UPS Bypass disabled.

- Enable: This option disables Bypass, and it cannot be enabled under any circumstances
- Disable: This option leaves Bypass enabled allowing it to function according to UPS configuration. This is the factory default value.

**NEUTRAL LINE CHECK**: Neutral Loss Detection Function.

- Disable: This option disables this function. The UPS will not be able to detect the loss of the neutral line connection.
- Auto: Activates neutral loss detection. If a neutral loss is detected, an alarm is generated, and if the UPS is turned on, it will switch to Battery Mode. Upon the recovery of the neutral, the alarm is turned off, and UPS automatically returns to Normal Mode.
- Check: Activates neutral loss detection during the UPS startup. If a neutral loss is detected, an alarm is generated, and if the UPS is turned on, it will switch to Battery Mode. Upon recovery of neutral line, the alarm does NOT turn off automatically, and UPS does not return to Normal Mode automatically.

**ISO COMPENSATION**: Allows increasing the UPS output voltage to compensate for the load of an isolation transformer connected UPS output.



**SCREEN: SETTING → ADVANCE → SERVICE → ELECTRONIC – PAGE 2 / 2**

## PARAMETERS IN THIS MENU:

**Bypass UPS off**: Bypass Mode When UPS Is Turned Off. This setting only applies when the "Bypass forbid" parameter is disabled.

- Enable: Choosing this option activates Bypass Mode when the UPS is turned off. Factory default setting.
- Disable: This option disables Bypass, so when the UPS is turned off manually, output also turns off

**Bypass Voltage Range**: Sets valid voltage range for Bypass Mode.

- 400/230V Models: Low Voltage Limit Range: 176V to 209V / High voltage Limit Range: 231V to 264V
- 208/120V Models: Low Voltage Limit Range: 96V to 110V / High voltage Limit Range: 130V to 146V

**FRE Range**: Sets valid frequency range for Bypass Mode.

- 50Hz Systems: 46Hz to 54Hz.
- 60Hz Systems: 56Hz to 64Hz.

**ECO Mode**: "Enable": Enables ECO Mode. "Disable": Disables ECO Mode. Factory setting: "Disable".

**ECO VOL Range**: Sets valid voltage range for Bypass ECO Mode.

- Low Limit: From -5V up to -11V below nominal voltage. Factory setting: -5V below nominal voltage.
- High Limit: From +5V up to +11V over nominal voltage. Factory setting: +5V over nominal voltage.

**ECO FRE Range**: Sets valid frequency range for ECO Mode

- 50Hz Systems: 46Hz to 54Hz.
- 60Hz Systems: 56Hz to 64Hz.

**SETTING → ADVANCE → SERVICE → SECOND SCREEN – BATTERY**



**SCREEN: SETTING → ADVANCE → SERVICE → BATTERY – PAGE 1 DE 2**

**PARAMETERS IN THIS MENU:**

**BATT Warning VOL:** Batteries voltages that trigger alarms.

- HIGH: High battery voltage alarm value. Available range: 14.0V to 15.0V. Factory setting: 14.4V
- LOW: Low battery voltage alarm value. Available range: 10.1V to 14.0V. This parameter must be higher than next one, **Shutdown VOL**. Factory setting: 11.4V

**Shutdown VOL:** If battery voltage drops under configured value, UPS shuts down. Available range: 10V to 12V. Factory setting: 10.7V.

**BATT Age:** Battery lifespan.

**BATT Parameters:**

- Battery AH: Battery Capacity in AH.
- BATT Group: Number of groups (battery strings connected in series) connected to the UPS, operating in parallel with each other.



**SCREEN: SETTING → ADVANCE → SERVICE → BATTERY – PAGE 2 DE 2**

**PARAMETERS IN THIS MENU:**

**BATT Study:** Intelligent battery test managing function for self-calibration. For future use, not available yet.

**BATT Initial:** Initialization of the UPS virtual battery capacity. This should be performed after replacing batteries with new ones. Available options:

- Yes: Resetting the virtual battery capacity to 100%.
- No: This value is not reset.

**BATT Cali Value:** Backup time calibration.

**BATT TEMP Compensation:** Setting for battery charge voltage compensation, according to temperature.

**SETTING → ADVANCE → USER → SECOND SCREEN – MISCELLANEOUS**



**SCREEN: SETTING → ADVANCE → SERVICE → MISCELLANEOUS**

**PARAMETERS IN THIS MENU:**

**Auto Restart:** After UPS shut down due to deep battery discharge, Auto-Restart Function allows UPS can automatically turn on when the electrical line is restored and return to Normal Mode (Online Mode). Available options:

- Enable: Factory setting. Enables this function.
- Disable: This option enables Auto Restart.

**Shutdown Delay:** UPS shuts down after the number of minutes entered in this field. Countdown starts upon confirming the command.

**Restore Delay:** After the shutdown from the previous command, UPS will restart after the number of minutes entered in this field.

**New Password:** This function changes the password to access **SETTING → ADVANCE → USER** Menu.

**DefaultUserPassword:** Restore access password for **SETTING → ADVANCE → USER** menu to its original value. Available options: 'YES' and 'NO'. 'YES' option restores the key to its factory value.

**BatteryLock:** Function for future use, not available yet.

**CONFIGURACION → ADVANCE → SERVICE → SECOND SCREEN – UPS SELF TEST**

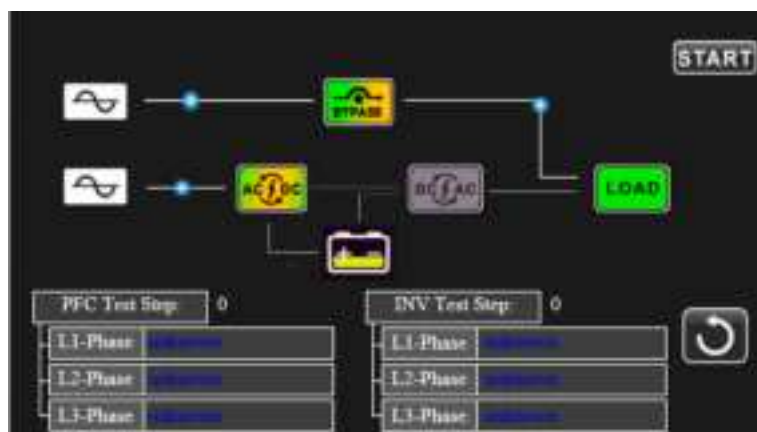

**SCREEN: SETTING → ADVANCE → USER → UPS SELF TEST**

UPS Self-test function, only to be performed only by highly qualified personnel.

To ensure this operation works correctly, two configuration parameters must be confirmed:



1. UPS type must be HV
2. **“Output Setting”** parameter must be 3-3



If one or both parameters do not meet the above conditions, before performing the UPS Self-Test, you should do the following:

- Disconnect the UPS from all system loads and power.

- Go to the **SETTING → ADVANCE→SERVICE → SYS PARAMETERS** menu and enter the following parameters:
  - **“UPS Type”** to change it to HV, if necessary.
  - **“Output Setting”** to change it to 3-3, if necessary.
 Refer to the information available in the **SETTING** section for details.
- After making the two changes above, you should restart the UPS.
- After UPS restart, please enter the **SETTING → ADVANCE→SERVICE** menu, which will show you the **UPS SELF TEST** option, among others. Select it, and the UPS will go to the screen shown in the figure above, displaying all fields as “Unknown”.
- Tap on the “START” icon for the UPS to begin the test. If UPS is working properly, fields will change to “Normal”; otherwise, they will remain in the 'Unknown' state.
- At the end of the test, the screen will automatically go black. If the UPS status is abnormal, it will display information on the screen.

**INFORMACION:**

You can access this menu by tapping the icon  and tapping the icon  takes you back to the main screen from any other screen.

As this page includes 2 screens, icons  and  can be used to scroll among them. Icon  returns to previous screen. Below is the initial screen of this menu:



**SCREEN: INFORMATION – BASIC – PAGE 1 / 2**

**DESCRIPTION OF LISTED VALUES – BASIC SCREEN 1 / 2:**

- MCU Version:** MCU Version
- DSP Version:** DSP Version.
- Serial NO.:** UPS Serial Number.
- Manufacturer:** Manufacturer.
- Service Contact:** Name of the previously configured service contact.
- Service Phone:** Previously configured Service phone number.
- Service Mail:** Previously configured Service email.



**SCREEN: INFORMATION – BASIC – PAGE 2 DE 2**

**DESCRIPTION OF LISTED VALUES – BASIC PAGE 2 / 2:**

**PAR State:** Displays the state of parallel connection.

**PAR ID:** UPS identification in the Parallel system.

**Customer Code:** Reserved for future use in the dynamic key system.

**DynamicPassword:** Reserved for future use in the dynamic key system.



**SCREEN: INFORMATION – RATED**

**DESCRIPTION OF LISTED VALUES – RATED SCREEN:**

**Output VOL:** UPS Nominal Voltage.

**Output FRE:** UPS Nominal Frequency.

**CVCF Mode:** Converter Frequency Mode status.

**Bypass Forbid:** Bypass Inhibition Function status.

**Bypass UPS Off:** UPS Bypass Function status when turning off the UPS.

**ECO Mode:** ECO Function status.

**Auto Restart:** Auto Restart Function status.



**SCREEN: INFORMATION – PARAMETER – PAGE 1 / 2**

**DESCRIPTION OF LISTED VALUES – PARAMETER – PAGE 1 / 2:**

**Line VOL Range:** Valid voltage range.

**Line FRE Range:** Valid frequency range.

**Bypass VOL Range:** Valid voltage range for Bypass Mode.

**Bypass FRE Range:** Valid frequency range for Bypass Mode.

**ECO VOL Range:** Valid voltage range for ECO Mode.

**ECO FRE Range:** Valid frequency range for ECO Mode.

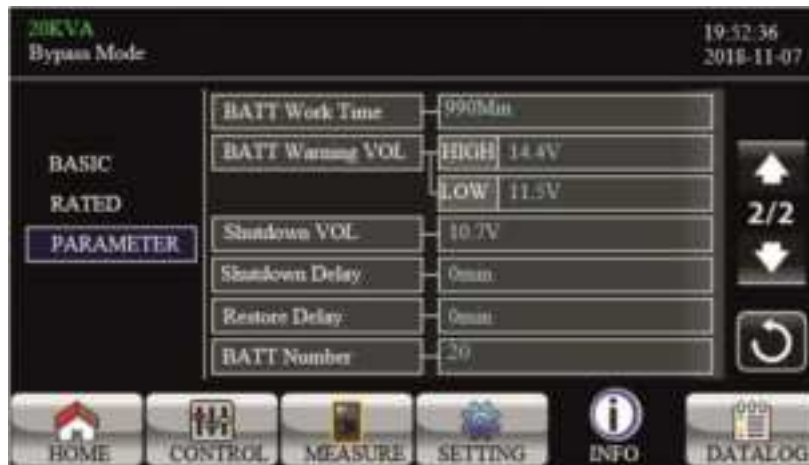

**SCREEN: INFORMATION – PARAMETER – PAGE 2 / 2**

**DESCRIPTION OF LISTED VALUES – PARAMETER – PAGE 2 / 2:**

**BATT Work Time:** Maximum backup time in Battery Mode.

**BATT Warning VOL:** Battery voltage levels that trigger alarms.

- HIGH: Alarm voltage (warning) for high battery voltage.
- LOW: Alarm voltage (warning) for low battery voltage.



**Shutdown VOL:** Battery level that causes the UPS to shut down.

**Shutdown Delay:** UPS time configured for UPS shutdown. 0 means no shutdown has been configured.

**Restore Delay:** Time for UPS restart after the configured shutdown.

**BATT Number:** Number of batteries in the UPS.

**DATA LOG:**

You can access this menu by tapping the icon  and tapping the icon  takes you back to the main screen from any other screen.

As this page may include more than 1 screen, icons  and  can be used to scroll among them. Icon  returns to previous screen.

Below is the initial screen of this menu:



**DATA LOG**

This section lists all events recorded by the UPS, indicating date and time of the incident, as well as code, type, and description.

This log can store up to 500 events, once the number is reached, new events are written over stored events, beginning by the oldest one toward more recent event.

For more information about fault codes and alarm descriptions, we suggest referring to Section **13. ERRORS, ALARMS & TROUBLESHOOTING** of this manual.

## 10.- START UP: SINGLE UPS

### INSPECTION BEFORE START-UP

- 1- Make sure all wires are tightly connected to terminal block. Any loose connection will produce overheating, failures, and damage to UPS.
- 2- Make sure all instructions of installation and wiring sections (4 & 5) have been correctly performed. Check wiring and breakers are correct.
- 3- Put the terminal block cover back in its position to avoid access to wiring.
- 4- Check Emergency Power Off (EPO) port is correct:
  - EPO Port closed (Wired): EPO function disabled
  - EPO port connected to an emergency switch: EPO function available by activation of Emergency Switch, which must be "Normally Closed" type to guarantee that UPS will shut down when circuit opens.
- 5- Check Maintenance Bypass Switch (MBS) located in UPS rear panel is in UPS position and its safety cover plate is duly installed.
- 6- Make sure all external protection devices in input and output lines are set to open (OFF) position.

### START-UP PROCEDURE. SINGLE UPS

- 1- Make sure all equipment connected to UPS are off.
- 2- Set ALL Battery Bank breaker to ON (in case UPS has XBAT connected)
- 3- Power-On input line at electrical board by setting Circuit Breaker to ON
- 4- Set AC INPUT Breaker to ON in UPS rear panel. LCD of UPS must turn on. Fans should start operating, and UPS will start self-diagnosis.
- 5- Set UPS Bypass breaker to "ON". If BYPASS mode is allowed, A short time later, the screen indicates that the UPS enters BYPASS mode. In models with an LED on the front panel, the BYPASS LED should light up. The outputs of the UPS are powered, although UPS is still off. In BYPASS mode, the output voltage comes directly from Bypass input without the UPS intervening.
- 6- Follow the UPS power-on procedure:
  - Touch **CONTROL** icon / Touch **UPS ON/OFF** command / Confirmation Question "**TURN ON UPS?**", Touch "**YES**".
- 7- A few seconds after, UPS should pass from BYPASS Mode to NORMAL Mode or AC Mode.
- 8- Sequentially, power-on each protected equipment. Front panel LCD should show the load increase as each equipment start.
- 9- Once all equipment is on, the total power consumption (load) should not exceed UPS capacity.
- 10- At this moment UPS working under NORMAL AC-MODE and the system is supplied by.



#### IMPORTANT NOTES:

1. Should any warning or failure message appear on Screen, or UPS operation is not as expected, check TROUBLESHOOTING section in this manual.
2. If the UPS triggers input circuit breaker when being powered, UPS might be configured to operate at a different frequency than the system it has been connected to. In this case, you should follow this procedure:
  - Set the AC Input Breaker (on UPS Back Panel) to OFF.
  - Open AC Input Breaker on Power Panel.
  - Start UPS pushing  button close to the screen.
  - When turning on your screen in Battery Mode, check configuration in **SETTING→ADVANCE→USER→Electronic**, review following parameters:
    - **CVCF MODE**: If this function is not required, set it to "**Disable**". So, UPS Will synchronize with AC Line frequency.
    - **OUTPUT FRE**: If **CVCF MODE** is required, set parameter **OUTPUT FRE** to the same value AC Line frequency.
  - Turn off the UPS and repeat the startup procedure.
3. The UPS batteries may not be fully charged at the time of UPS installation. For the first time, the UPS will require approximately 10 hours to fully recharge the batteries.

### **START-UP PROCEDURE WITHOUT POWER. SINGLE UPS BATTERY MODE**

---

This procedure is to be performed with the UPS completely disconnected from AC power, as a recommended practice for testing the UPS before installation and verifying the equipment's configuration. For handling the screens and configuration menus, please refer to Section 9. **UPS OPERATION & CONFIGURATION**. The startup procedure is as follows:

1. If there are external batteries, ensure the battery bank is properly connected to the UPS and the switch is turned on (ON).
2. Turn on the UPS using the power button . At this moment, the UPS should power on its screen and begin initialization.
3. Within a few seconds, the UPS should enter Stand By mode and then Battery Mode, powering its outlets.
4. From this point, you can check UPS configuration or supply power to devices connected to its outlets.
5. Follow the UPS turn-off procedure:  
Touch **CONTROL** icon / Touch **UPS ON/OFF** command. / Confirmation prompt "**TURN OFF UPS?**", touch "YES."

UPS will turn off its outlets.

**11.- STARTUP: PARALLEL UPS**

**INSPECTION BEFORE STARTUP**

**OUTPUT VOLTAGES REVISION**

When multiple UPS operate in parallel, their outputs are connected to each other, and each UPS provides a proportional share of the total system power. In this type of system, it is VERY IMPORTANT that voltage supplied by the inverters of all UPS is similar. The voltages should not differ by more than 1.0 Volt AC. Follow the procedure described below to check the output voltages of each UPS:

- 1- Ensure that the parallel control cables are not connected between UPS.
- 2- Make sure the external output breakers are in the OFF position.
- 3- First step is to start each of the UPS units **separately** and measure their output voltage in ONLINE mode individually.
- 4- **WARNINGS:**  
**During this process, NEVER have 2 UPS units running at the same time.**  
**Voltage measurements should be taken using the same high-quality and highly precise digital voltmeter.**  
**Measurements of all 3 UPS units should be performed consecutively.**

**UPS #1 VOLTAGE MEASUREMENT**

- Connect external battery banks to UPS #1. Provide power ONLY to UPS #1, keeping the others unpowered.
- Wait for UPS #1 to perform its self-diagnosis, power on its display, and enter BYPASS mode. Screen will clearly indicate this.
- Follow the UPS power-on procedure:  
 Touch **CONTROL** icon / Touch **UPS ON/OFF** command / Confirmation Question "**TURN ON UPS?**", Touch "**YES**".
- Wait for it to enter ONLINE mode and use a digital voltmeter to measure the output voltage, then take a note of it.
- Follow the UPS turn-off procedure:  
 Touch **CONTROL** icon / Touch **UPS ON/OFF** command. / Confirmation prompt "**TURN OFF UPS?**", touch "**YES.**"
- Cut the power to UPS #1 input and wait until LCD screen turns off.

**UPS #2 VOLTAGE MEASUREMENT**

Repeat previous steps on UPS #2 and take note of the output voltage.

**UPS #3 VOLTAGE MEASUREMENT**

Repeat previous steps on UPS #2 and take note of the output voltage.

	UPS # 1 (Vac)	UPS # 2 (Vac)	UPS # 3 (Vac)
L1 - N:			
L2 - N:			
L3 - N:			

If output voltages on all 3 UPS show a difference under 1.0 VAC, proceed with startup process. Otherwise, adjust output voltage on the UPS that require it.

**IMPORTANT NOTES:**

- Adjustment process should be carried out on one UPS at a time. During adjustment process, avoid having more than 1 UPS in operation.
- Adjust procedure should be done according to section **9. UPS OPERATION & CONFIGURATION**, in section **SETTING → ADVANCE → SERVICE → VOL CALI → INVERTER VOL.**

---

**ESSENTIAL REQUIREMENTS FOR PARALLEL CONNECTION**

---

**WARNING:**

**If all requirements listed below are not met, a successful startup of the parallel UPS system cannot be carried out..**

- 1- Maximum number of units in parallel is 3. Do not try with more than 3 units.
- 2- All UPS must be of the same model and must have the same firmware version. Consult your distributor, who, based on the UPS serial numbers, can confirm if the firmware version of the UPS units is compatible for parallel operation.
- 3- Configuration of ALL configurable parameters on the screens must be the same for all UPS. If any parameter in any of the UPS does not match the others, an error or malfunction may occur.
- 4- The maintenance bypass switch (MBS) of all units must be in the "UPS" position, and its cover must be installed.
- 5- If there are external batteries, each UPS must have its own external battery pack. UPS units cannot share battery packs.
- 6- All UPS must be connected through their parallel control ports (parallel control cables and shared current cables) - as described in the parallel wiring section in this manual.
- 7- The sum of all UPS capacities must cover the total power connected to the parallel system. It is recommended that the total UPS power is at least 25% higher than the load that will be protected. If you want the system to continue working in the event of one UPS failure, the system should be sized so that the maximum load can be handled by all UPS except one. In other words, for a system of 3 UPS units, the maximum load should be managed by 2 UPS units, and the third one will serve as a backup in case of failures. If the system consists of 2 UPS units, a single UPS unit should be capable of manage the entire load. This is known as n+1 redundancy.

---

**INSPECTION BEFORE STARTUP**

---

One all UPS output voltages are confirmed to be appropriately adjusted, check the following points:

- 1- Make sure all wires are tightly connected to terminal block. Any loose connection will produce overheating, failures, and damage to UPS.
- 2- Make sure all instructions of installation and wiring sections (5 & 7) have been performed correctly. Check wiring and breakers are correct.
- 3- Put the terminal block cover back in its position to avoid access to wiring.
- 4- Check Emergency Power Off (EPO) port is correct:
  - EPO Port closed (Wired): EPO function disabled
  - EPO port connected to an emergency switch: EPO function available by activation of Emergency Switch, which must be "Normally Closed" type to guarantee that UPS will shut down when circuit opens.
- 5- Check Maintenance Bypass Switch (MBS) located in UPS rear panel is in UPS position and its safety cover plate is duly installed.
- 6- Make sure all external input and output Circuit Breakers are set to open ("OFF") position.
- 7- Verify parallel control cables are properly connected.

**STARTUP PROCEDURE. PARALLEL UPS**

**WARNING:** If all the requirements listed below are not met, a successful startup of the parallel UPS system cannot be carried out.

- 1- Make sure all equipment connected to UPS system are off.
- 2- Check that the AC input switches on the rear panels of all UPS are set to "OFF" position.
- 3- Set ALL Battery Bank breakers to ON (in case UPS have XBAT connected).
- 4- Power-On input AC line at electrical board by setting Circuit Breaker to ON.
- 5- Check L1 Phase voltage between UPS in the system. If wiring is correct, the voltage between L1 Phase of different UPS should be close to a 0Vac. Repeat measurement for phases L2 and L3.
- 6- If input wiring is correct, set AC input switch to "ON" position on the rear panel of ALL UPS in the system.
- 7- Set the BYPASS switch to "ON" position on the rear panel of ALL UPS units in the system.
- 8- Wait for ALL the UPS units to turn on their displays and enter BYPASS mode:
  - If BYPASS mode is allowed (according to UPS configuration), all UPS should go to BYPASS mode waiting to be started.
  - If BYPASS mode is not allowed, UPS will enter standby mode with their outputs unpowered, waiting to be started.
- 9- This can be a good moment, if not done previously, to confirm that settings of all UPS are similar. Check the configuration menu of each UPS. Ensure that the configuration of ALL parameters is the same for ALL UPS. Refer to the configuration section of this manual.
- 10- Once it has been confirmed that settings of all configurable parameters of all UPS are similar, set the external output switches of all UPS units to the 'ON' position so their outputs can connect to each other.
- 11- Arranque secuencialmente TODOS los UPS mediante el procedimiento de encendido:  
Touch **CONTROL** icon / Touch **UPS ON/OFF** command / Confirmation Question "**TURN ON UPS?**", Touch "**YES**".
- 12- A few seconds after, ALL UPS should synchronize to pass from BYPASS Mode to NORMAL Mode. Parallel system is working correctly.

**IMPORTANT NOTES:**

1. Should any warning or failure message appear on Screen, or UPS operation is not as expected, check TROUBLESHOOTING section in this manual.
2. If the UPS triggers input circuit breaker when being powered, UPS might be configured to operate at a different frequency than the system it has been connected to. In this case, you should follow this procedure:
  - Set ALL AC Input Breakers (on UPS Back Panel) to OFF.
  - Open Main AC Input Breaker on Power Panel.
  - Start each UPS pushing  button close to the screen.
  - When turning on screen in Battery Mode, check configuration in **SETTING→ADVANCE→USER→Electronic**, review following parameters:
    - **CVCF MODE**: If this function is not required, set it to "**Disable**". So, UPS Will synchronize with AC Line frequency.
    - **OUTPUT FRE**: If **CVCF MODE** is required, set parameter **OUTPUT FRE** to the same value AC Line frequency.
  - Turn off each UPS and repeat the startup procedure.
3. The UPS batteries may not be fully charged at the time of UPS installation. For the first time, the UPS will require approximately 10 hours to fully recharge the batteries.

## 12.- OPERATIONS: PARALLEL UPS

Operating modes of UPS connected in parallel are essentially the same as those of single operating UPS. However, it's important to note that in a parallel system, ALL UPS must operate in the same mode simultaneously. Parallel connection does not allow any UPS to operate in a different mode from the rest UPS in the system.

### Removing a UPS from a Working Parallel System

There are two (2) ways to isolate a UPS from a parallel system:

#### **A) Total Shutdown:**

Shutting down all UPS in an orderly manner, and then isolating the UPS to be removed from the system by opening the switches and breakers.

#### **B) Removing a UPS while keeping the other UPS in the system in Online mode:**

\*\* Check the compliance with all requirements listed below:

#### Basic Requirements for Intervening in a UPS Operating in a Parallel System.

- 1.- Procedure must be carried out exclusively by highly trained personnel with full knowledge of UPS and the electrical installation they work with.
- 2.- The operation must be coordinated with the system administrator, who should be informed of the risk of a potential system shutdown in case of unexpected events, such as:
  - Power outage during the intervention, and the remaining units may not provide sufficient backup time to keep the system operational before reintegrating the intervened UPS,
  - Unexpected activation of any circuit protection devices that could trigger a general shutdown or unexpected UPS system failure, etc.
- 3.- There must be a written plan detailing each step of the operation.
- 4.- UPS that will remain operational must have the capacity to supply required power (continuous and peak) to the system once the UPS being intervened is removed.
- 5.- Each UPS should have its own external Circuit Breakers, so the UPS can be disconnected and isolated from the parallel system.
- 6.- There must be enough workspace to work comfortably on the UPS to be maintained without interfering with UPS that will remain operational.

**Note: Non-compliance with any of these requirements prohibits individual intervention and requires a complete system intervention.**

#### **If all the requirements are met, proceed as follows:**

1. Follow the UPS turn-off procedure:  
Touch **CONTROL** icon / Touch **UPS ON/OFF** command. / Confirmation prompt "**TURN OFF UPS?**", touch "YES."

#### **NOTE:**

Once powered off, UPS shuts down outputs and enters a state like being powered off, but with LCD still active. UPS cannot enter BYPASS mode since it is connected to other UPS that energized outputs.

From this moment on, any main power supply failure will be managed by other UPS.

2. Turn off (set to OFF) the UPS output breaker/switch to electrically isolate its outputs.
3. Turn off (set to OFF) the UPS AC input breaker/switch located on the rear panel of the intervened UPS.
4. In case there are external batteries, turn off (set to OFF) the battery breaker/switch.
5. Wait for a few seconds until the display on the intervened UPS turns off.
6. Open external input protections (Breakers) to electrically isolate its inputs.
7. Disconnect, ONLY at the rear panel of the UPS to be removed, parallel control cables (Parallel and Shared Current). Other UPS should keep their parallel cables unchanged.

#### **NOTE:**

If any of the cables from the other UPS that will remain operational are disconnected, a communication error will occur, disrupting the system normal operation.

At this point, the UPS is powered off, electrically isolated from the system, and ready for individual intervention or removal from the system.

**Adding an UPS to an Operative Parallel System**

- Adding a new UPS to a parallel system that is currently operational is not possible. System must be powered off to include the new UPS.
- Total number of parallel UPS should not exceed 3 units for this model.
- Firmware of all UPS to be connected in parallel must be compatible.
- Setting (parameters from the LCD Setting Menu) of the UPS to be added must exactly match setting of already installed UPS.
- Follow the procedure outlined in this manual to install the new UPS units in parallel system.

**Static-Bypass Mode Through Shutdown Procedure**

Although bypass mode is allowed in the configuration of each UPS in the system, if an attempt is made to put one of them in internal static bypass mode using the shutdown procedure described in the previous section, this UPS will be put in STANDBY mode (with outputs turned off) since it is impossible to assume bypass mode while other UPS are in ONLINE mode.

**Maintenance-Bypass Mode Through MBS SWITCH**

If the safety plate of the manual bypass switch (MBS) is removed from one of the UPS in the system, this UPS will enter bypass mode and force all other UPS in the system to enter bypass mode as well. To adopt this mode of operation, please refer to the section dedicated to MAINTENANCE BYPASS mode in this manual for detailed instructions.

### 13.- ERRORS, ALARMS & TROUBLESHOOTING

#### ERROR / FAILURE CODES ON SCREEN

If a malfunction or failure occurs in the UPS, an error code and description will be displayed on the UPS screen, which will help identify the issue that needs to be addressed by technical support. Error codes are accompanied by a continuous and noticeable alarm to ease the identification of the situation.

The following table lists error codes and descriptions for this UPS family:

**WARNING:** Many of these fault or error conditions can lock the UPS for safety reasons.

FAULT CODE (ERROR)	FAULT (ERROR) DESCRIPTION
1	Bus Start failure
2	High BUS Voltage
3	Low BUS Voltage
4	Bus Unbalanced
6	Converter Over Current
11	Inverter soft start failure
12	Inverter High voltage
13	Inverter Low voltage.
14	Inverter A (L1) output line to neutral short-circuit
15	Inverter B (L2) output line to neutral short-circuit
16	Inverter C (L3) output line to neutral short-circuit
17	Inverter A-B (L1-L2) output (line to line) short circuit detected.
18	Inverter B-C (L2-L3) output (line to line) short circuit detected.
19	Inverter C-A (L3-L1) output (line to line) short circuit detected.
1A	Inverter A (L1) Negative Voltage failure
1B	Inverter B (L2) Negative Voltage failure
1C	Inverter C (L3) Negative Voltage failure
21	Battery SCR Short-Circuit
23	Inverter Relay Open-circuited
24	Inverter Relay Short-circuit
25	Line Wiring Fault
31	Parallel communication failure
41	HIGH Temperature.
42	DSP communication failure
43	UPS Overload: High power consumption in Watts at UPS output.

FAULT CODE (ERROR)	FAULT (ERROR) DESCRIPTION
45	Charger Fault.
46	Incorrect UPS setting.
47	MCU communication failure
61	Bypass SCR short-circuited
62	Bypass SCR open-circuited
63	Voltage waveform abnormal in R phase (L1).
64	Voltage waveform abnormal in S phase (L2).
65	Voltage waveform abnormal in T phase (L3).
66	Inverter current sample abnormal
67	Bypass output short-circuited
68	BYPASS output LINE to LINE short-circuited
69	Inverter SCR short-circuited
6C	BUS voltage drops too fast
6D	Current sampling error value
6E	SPS power error
6F	Battery polarity reverse
71	Rectifier IGBT overcurrent in R phase (L1).
72	Rectifier IGBT overcurrent in S phase (L2).
73	Rectifier IGBT overcurrent in T phase (L3).
74	Inverter IGBT overcurrent in R phase (L1).
75	Inverter IGBT overcurrent in S phase (L2).
76	Inverter IGBT overcurrent in T phase (L3).
77	ISO Over temperature fault
78	LCD & MCU communication failure

**WARNING CODES LIST**

WARNING CODE	WARNING DESCRIPCION
1	Battery not connected
2	Input Neutral loss
4	Input Phase Abnormal
5	Bypass phase abnormal
7	Battery over charge
8	Low battery
9	Overload
0A	Fan failure
0B	EPO enable
0D	Over temperature
0E	Charger failure
21	In parallel systems: line situation different
22	In parallel systems: bypass situation different

WARNING CODE	WARNING DESCRIPCION
33	Locked in bypass after overload 3 times in 30min
34	Converter current unbalance
36	Inverter inter-current unbalance
3A	Cover of maintenance switch is open
3C	Utility extremely unbalanced
3D	Bypass unstable
3E	Battery Voltage too high
3F	Battery voltage unbalanced
40	Charger short circuited
41	Bypass loss
42	ISO over temperature
43	Bus soft start error

**WARNING:**
**ALARMS ELIMINATION:**

**\*\* Some alarms can lock the UPS, preventing its normal operation even after the original fault that triggered the alarm has been resolved. The technician must ensure that the original fault has been resolved and then eliminate the alarm condition using the procedure explained in section 9. UPS OPERATION AND CONFIGURATION, of this manual.**

**MEANING OF AUDIBLE ALARMS**

Descripción	Buzzer status	Muted
<b>UPS status</b>		
Bypass mode	Beeping once every 2 minutes	Yes
Battery mode	Beeping once every 4 seconds	
Fault mode	Beeping continuously	
<b>Warning</b>		
Overload	Beeping twice every second	No
Others	Beeping once every second	
<b>Fault</b>		
All	Beeping continuously	Yes

**TROUBLESHOOTING: SOLVING PROBLEMS**

SITUATION	PROBABLE CAUSE	ACTION
Screen loses the input voltage indication. AC input failure alarm is activated (1 beep/4 s). However, the main power supply is normal	UPS AC input cable is not properly connected	Check UPS AC Input wiring and correct if necessary.
	UPS AC input cable is connected to UPS output	Check UPS AC Input wiring and correct if necessary.
UPS cannot be turned on, even though AC input is normal. Audible alarm is activated with 1 beep per second, and the code <0B> is shown on screen.	EPO function is active.	Close EPO port circuit for UPS to go back to normal.
UPS cannot be turned on, even though the AC input is normal.	Wrong UPS Power-on procedure.	Follow UPS Power-on procedure: - Touch <b>CONTROL</b> icon - Touch <b>UPS ON/OFF</b> command - Confirmation question " <b>TURN ON UPS?</b> ", touch " <b>YES</b> "
When powering the UPS, entering Bypass mode, or attempting to turn it on, the UPS trips the input circuit breaker	UPS might be configured to generate a frequency different from AC Input Line. For example: 50Hz in a 60Hz site 60Hz in a 50Hz site	Power-on UPS in battery mode with  button. After Screen power-on go to <b>SETTING</b> → <b>ADVANCE</b> → <b>USER</b> → <b>Electronic</b> Menu and check parameters: - <b>CVCF MODE</b> : If not needed, set it to " <b>Disable</b> ". - <b>OUTPUT FRE</b> : If <b>CVCF MODE</b> is enabled, set this parameter to Bypass input frequency. Restart UPS.
Alarm sounds 1 every second, and alarm message <01> is displayed.	Wrong battery connection (internal or external).	Check and correct battery connection, if necessary.
Alarm sounds 1 every second, and code <02> is displayed.	Input Neutral disconnected or the fuse in one of input lines is melted.	Check and correct Neutral connection, if necessary. Check fuses on input lines and replace if necessary. If Neutral and Fuses are fine and error is still on, review settings in <b>SETTING</b> → <b>ADVANCE</b> → <b>USER</b> → <b>Electronic</b> Menu. Set <b>Neutral Line Check</b> parameter to <b>Check</b> and restart UPS.
Alarm sounds 1 every second, and code <0A> is displayed.	UPS Fan locked or spinning slower than expected. UPS overheating.	Check UPS Fan operation and contact Technical Support.
Alarm sounds 2 times per second, and code <09> is displayed. Bypass mode activated.	UPS overloaded. Loads exceed UPS capacity. UPS in Bypass Mode to feed protected equipment from Bypass Input.	Disconnect loads from UPS output until the situation is solved.
	After repeated overloads UPS is locked in Bypass mode.	Disconnect loads from UPS output until the situation is solved. Turn-off UPS and restart it again.
Alarm sounds continuously, and the code <43> is displayed.	UPS automatically turned-off due to output overload.	Disconnect loads from UPS output until the situation is solved and restart it again.
alarm sounds continuously, and one of the following codes is displayed: <14>, <15>, <16>, <17>, <18>, or <19>	UPS automatically turned-off due to output short-circuit.	Check the wiring and the equipment connected to UPS output. Solve the issue once identified.
Any code from the error table and continuous alarm.	Possible UPS damage.	Contact Technical Support.
Backup time is shorter than expected	Batteries not fully charged, or batteries degraded.	Recharge batteries for 6 hours. If situation remains, contact Technical Support.

## **14.- MAINTENANCE BYPASS MODE (MBS)**

### **STARTING MAINTENANCE BYPASS MODE:**

- 1- If UPS setting allows BYPASS mode, proceed to power-off UPS using the procedure explained in section **9. UPS OPERATION & CONFIGURATION**.  
Shutdown makes UPS to go to internal STATIC-BYPASS Mode. UPS output will connect to Bypass input through static bypass line.
- 2- When screen confirms UPS entered internal Bypass Mode, remove safety plate from MBS switch.
- 3- Move “MBS” switch from UPS position to MBS position.
- 4- At this moment, UPS output is connected to Bypass input using static Bypass line. See Internal Blocks Diagram section, in this manual.
- 5- Open UPS AC Input switch and wait until screen turns off. Now, UPS is disconnected from AC Input Line.
- 6- Open DC switches of ALL external battery packs.  
If UPS has no internal batteries, it is isolated from all power sources.  
If UPS has internal batteries, internal DC circuits are still powered. Technician must take precautions to disconnect internal batteries in case an UPS intervention is required.

**IMPORTANT WARNING: Any procedure or intervention must be performed ONLY by qualified personnel.**

### **RETURNING TO OLINE MODE FROM MAINTENANCE BYPASS MODE:**

- 1- Close the AC Input switch in the UPS.
  - 2- Feed the UPS, as explained in section **9. UPS OPERATION & CONFIGURATION**.
  - 3- Move MBS switch from “MBS” position to “UPS”.
  - 4- Install back the “MBS” safety plate.
- At this point, UPS is in Static-BYPASS mode, and it can be powered-on according to the procedure already described in this manual.

## 15.- EMERGENCY POWER OFF (EPO)

UPS counts on a 2 input terminals port as EPO (Emergency Power Off) input. Refer to image below for details. These terminals are connected in factory (Closed Contact) to avoid the emergency stop status.

For connecting an Emergency Stop Switch to UPS EPO port (C2), remove the original jumper and connect an appropriate switch (Normally Closed Contact). This must be done with UPS turned off. Otherwise, when removing the EPO Jumper (C2), UPS will immediately turn-off. This kind of switch is not included in the UPS, if required, switch must be purchased separately.

When switch is opened, UPS executes immediately the emergency power off function.

- **EPO function immediate result:**
  - Rectifier and Inverter are stopped.
  - UPS Internal STATIC BYPASS SWITCH opens leaving UPS output unpowered. (Output Off)
- **If the UPS on which EPO function is activated is in parallel system with other UPS, the emergency stop will act on all UPS in the system, turning off the system completely.**

### RESTART

To restart a UPS which has been powered off via EPO port, it is necessary to turn it off and cut power completely before restarting it again.

- 1.- Turn off UPS from Screen.
- 2.- Open AC input switch (OFF position).
- 3.- Open external battery switch if there are external batteries (OFF position).
- 4.- Wait until Screen turns off.

**At this point, UPS can be started-up according to standard power-on procedure explained in this manual.**

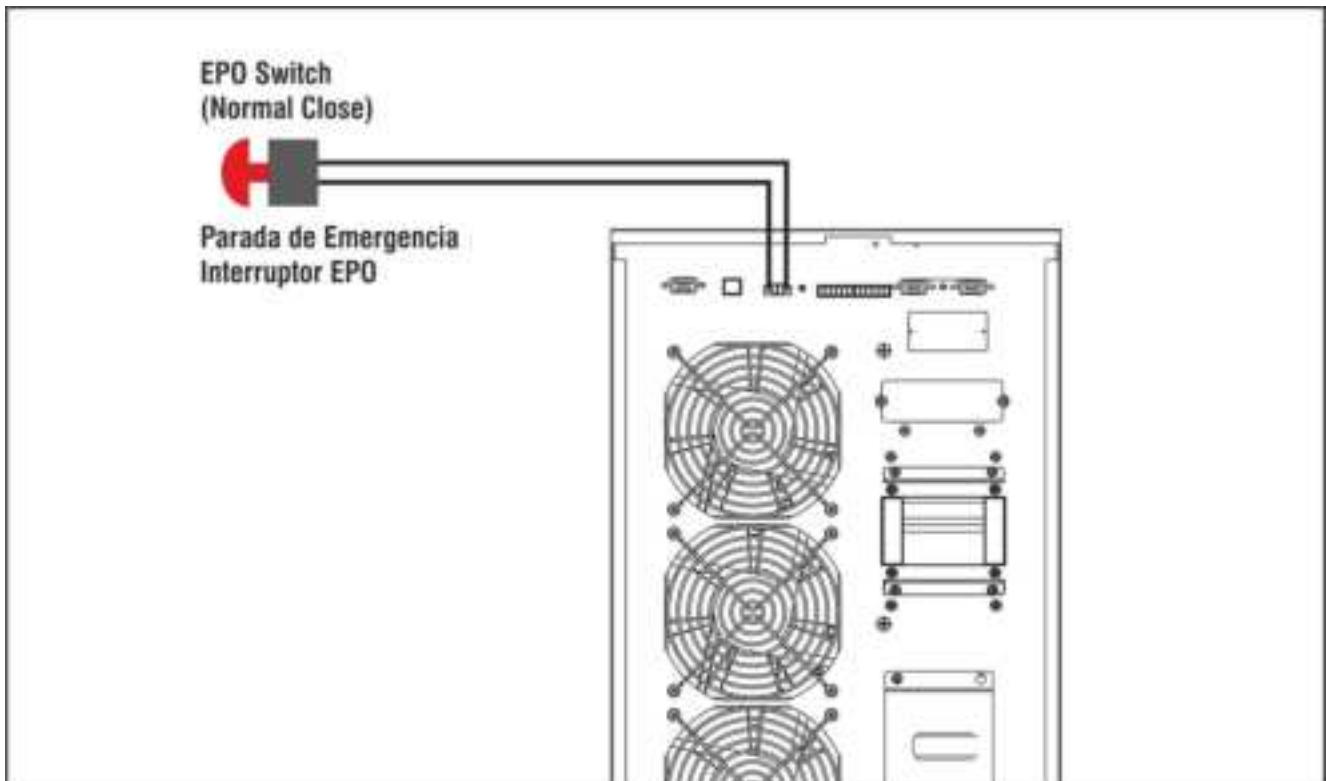

**16.- COMMUNICATION OPTIONS****USB PORT:**

For communicating with a PC using the XSMART Viewpower software. Software is available on CD and on our website: [www.xmart-ups.com](http://www.xmart-ups.com).

**RS-232 PORT:**

Serial communication port that allows communicating with a PC using the XSMART Viewpower software. Software is available on CD and on our website: [www.xmart-ups.com](http://www.xmart-ups.com).

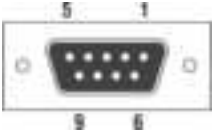

**Serial Data Port – Pin out:** Pin 2: RX: Data Reception  
Pin 3: TX: Data Transmission  
Pin 5: GND: Signal Ground

**IMPORTANT NOTE:**

Serial communication cable to be used with RS-232 port must be wired 1 to 1, between pins 2, 3, and 5 on both ends.

**SMART PORT:**

Smart port can accommodate the following communication cards:

**TARJETA DE RED ETHERNET – SNMP:**

Tarjeta opcional (no incluida con el UPS) que permite comunicar el UPS con redes LAN Ethernet. Funciona insertada en el puerto inteligente ubicado en el UPS. Una vez que el UPS se encuentra en la red, el UPS puede comunicarse con los PC de esa red, mediante el software de comunicación XSMART o bien mediante navegador de internet, haciendo referencia a la dirección IP De asignada a la tarjeta. Para mayores detalles consulte el manual del software Viewpower PRO y de la tarjeta de red SNMP.

**TARJETA AS400:**

Es una tarjeta opcional (no incluida con el UPS) de contactos secos que se inserta en el puerto inteligente. Esta tarjeta tiene 6 salidas y una entrada de contactos secos. Para mayores detalles se recomienda consultar el manual de usuario de la tarjeta AS-400

**TARJETA RS485:**

Es una tarjeta opcional no incluida con el UPS. Funciona insertada en el puerto inteligente. Esta tarjeta ofrece comunicación bajo el protocolo MODBUS. Se recomienda consultar el manual de la tarjeta RS485-MODBUS.

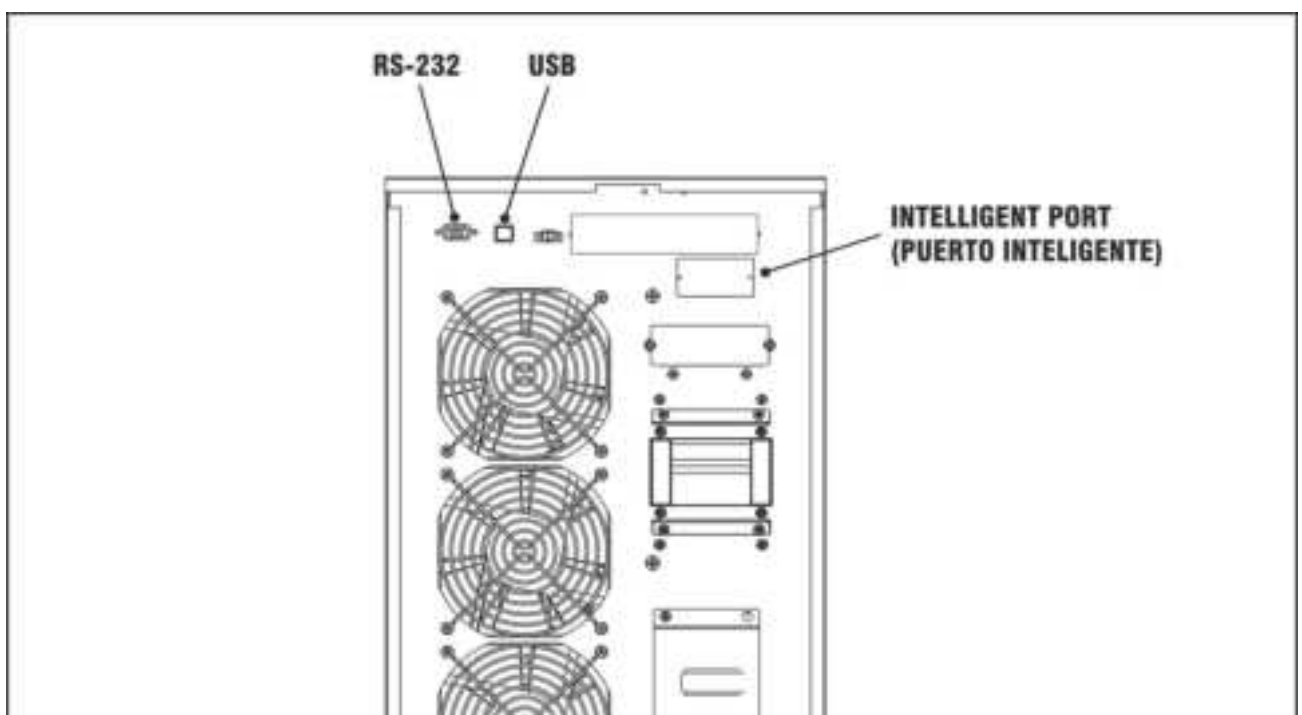

**17. TECHNICAL SPECIFICATIONS – 400/230V MODELS (1/2)**

OPTIMA-33 T10 (400/230V) Page 1 of 2	10K-400	20K-400	30K-400	40K-400	60K-400-NB	80K-400-NB
Capacity / Capacidad (VA)	10KVA	20KVA	30KVA	40KVA	60KVA	80KVA
Capacity / Capacidad (W)	10KW	20KW	30KW	40KW	60KW	80KW
Parallel Units / Unidades en Paralelo	3					
Input-Output / Entrada-Salida	3Ph-3Ph					
<b>INPUT / ENTRADA</b>						
Phase / Fases	(Y) : 3Ph + N + G					
Input Range / Rango de Entrada	L-N: (176Vac-276Vac) @ >=80% Load L-N: (X-276Vac) @ 50% <= Load < 80%; X=110V + (220*(Load-50%)) L-N: (110Vac-300Vac) @ < 50% Load					
Max. Current / Corriente Max. (130% load, A x ph.)	22A	43A	65A	87A	130A	173A
Frequency Range / Rango de Frecuencia	Autosensing: 50Hz: (46-54Hz) / 60Hz: (56-64Hz)					
Power Factor / Factor de Potencia	> 0.99 @ 100%load					
THDi (IEC 62040-3)	< 4% @ 100% load < 6% @ 50% load (IEC61000-3-4)					
Slew Rate / Seguimiento de Frecuencia:	1 Hz / s					
<b>OUTPUT / SALIDA</b>						
Phase / Fases	(Y): 3Ph + N + G or (DELTA): 3Ph + G					
Voltage / Tensión de Salida	360/208Vac - 380/220Vac - 400/230Vac - 415/240Vac (*N1)					
Voltage Regulation / Regulación de Salida:	+/- 1%					
Max. Angle Deviation / Max. Desviación de Fase	2° (EN-62040-3)					
Max. Voltage Unbalance Ratio / Desbalance Max.	1% (EN-62040-3)					
Frequency / Frecuencia (Batt. Mode)	50 Hz +/- 0.1 Hz / 60 Hz +/- 0.1 Hz					
Current Crest Ratio / Factor de Cresta	3:1 @ 100% load					
THDv (IEC 62040-3)	< 2% @ Linear Load / Carga Lineal <5% @ No Linear Load / Carga no Lineal					
Dynamic Accuracy / Regulación Carga Variable	<5% (load variations 0%-100% & 100%-0% R Load)					
Transient Recovery / Recuperación Cambio Carga	100ms / 90% vs (0%-100% & 100%-0% R load)					
Transfer Times / Tiempos Transferencia:	0 ms					
Waveform / Forma de Onda	Sine Wave / Sinusoidal Pura					
Power Output / Salidas	Terminal Block / Regleta de Conexión					
DC Offset / Componente DC	50mV max.					
<b>INTERNAL BYPASS</b>						
Bypass type / Tipo de Bypass:	SCR board / Tarjeta SCR					
Input Range in Bypass / Rango entrada en Bypass:	176-264Vac (L-N) & 50/60 +/- 4Hz Freq.					
<b>PROTECTION SYSTEMS / SISTEMAS DE PROTECCION</b>						
Surge & Spikes Suppression / Supresión de Picos	(L-N: 2.340J) + (LG: 2.340J) + (N-G: 780J) = TOTAL=5.460J (10/1000us)					
Output Short-Circuits / Cortocircuitos a la Salida (ONLINE)	Electronic inverter shortcircuit protection / Protección del inversor contra cortocircuitos: < 100ms: Current limited to max. capacity / Corriente limitada al 100% de Capacidad > = 100ms: Outputs shutdown. UPS goes to Fault Mode / SAI/UPS apaga las salidas y pasa a Modo Falla					
AC Input Current / Sobre-Corriente de Entrada AC	Input breaker or fuse Disyuntor o fusible de entrada					
Battery overcurrent / Sobrecorriente de baterías	Internal Fuse protection in battery line Protección por fusibles en línea de baterías interna					
Phase rotation / Fases de entrada intercambiadas	Alarm & turn-on disable Alarma y arranque prohibido					
Repetitive Overloads / Overloads repetitivos	3 overloads in 30min = UPS locks in bypass 3 overloads en 30min = UPS a bypass					
Starting Time / Tiempo de Arranque	7s - 10s (@ 100% load)					
<b>EFFICIENCY / EFICIENCIA</b>						
Eco Mode (100%/75%/50%/25% load)	98% / 98% / 97% / 97%					
AC Mode / Modo AC (100%/75%/50%/25% load)	95.5% / 94.5% / 93.5% / 91.5%					
Battery / En Batería (100%/75%/50%/25% load)	94.5% / 93.5% / 92.5% / 90.5%					
Inverter Efficiency / Eficiencia Inversor	97% inverter @ 100% load					
BTU @ 100% LOAD	1536	3071	4607	6142	9213	12284
<b>OVERLOAD / SOBRECARGA</b>						
AC Mode / Modo Normal	[100%-110%: 60m] [110%-125%: 10m] [125%-150%: 1m] [>150%: 1s] to bypass					
Battery Mode / Modo Batería	[100%-110%: 60m] [110%-125%: 10m] [125%-150%: 1m] [>150%: 1s] to cut-off					
Bypass	[100%-130%: OK] [>130%: 1min]					

**TECHNICAL SPECIFICATIONS – 400/230V MODELS (2/2)**
**OPTIMA-33 T10 (400/230V) Page 2 of 2      10K-400      20K-400      30K-400      40K-400      60K-400-NB      80K-400-NB**

<b>BATTERIES / BATERIAS</b>						
Battery Type / Tipo de Baterías	VRLA Sealed & Free maintenance / Sellada de libre mantenimiento VRLA (12V-9AH)					
Batteries location / Ubicación de las Baterías	Internal / Internas			External (XBAT) / Externas (XBAT)		
Battery Voltage / Voltaje de Baterías	+/-120VDC					+/- 240 VDC
Charging Amps / Corriente de Carga	1A - 12A Adjustable (According to/ De acuerdo con DIN41773).					
Recharging Time / Tiempo de recarga (90%)	2h - 3h (*N2)					
Charging Voltage / Voltaje del cargador (Floating)	+/- 136.5V					+/- 273 V
Temp. Compensation / Compensación Temp.	120mV/°C per battery (Input Air Temp/ Temp. Aire entrada: 25-50°C)					
Shutdown battery Voltage / Voltaje DC Apagado	10.7V/batt (0-30% load) 10.2V/batt (30-70% load) 9.6V/batt (load >70%)			10.7V/batt		
Low Battery Warning / Aviso de Baterías Baja	11.4VDC per Battery					
Max. DC Current / Corriente DC Max.	52A DC	104A DC	156A DC	208A DC	281A DC	374A DC
<b>INDICATORS / INDICADORES</b>						
5 Inches Touch Screen / Pantalla Táctil de 5 Pulg.	Full Status, Error Codes and Real Time Values Estado, Códigos Error y Valores en Tiempo Real					
<b>ALARM / ALARMAS</b>						
Acoustic Beep Alarm / Alarma sonora:	Battery, Low Battery, Overload, UPS Failure Modo Batería, Batería Baja, Sobrecargas, Falla del UPS					
<b>PRODUCT SIZE &amp; NET WEIGHT / TAMAÑO Y PESO NETO (DxWxH) / (mm) / (Kg)</b>						
SIZE: UPS (with internal batteries)	626*250*750		815*300*1000		-	-
WEIGHT: UPS (with internal batteries)	126	141	230	260	-	-
SIZE: UPS (no internal batteries)	-	-	-	-	790*360*1010	
WEIGHT: UPS (no internal batteries)	-	-	-	-	112	117
SIZE: Ext. Batt Cab. / Baterías Externas	592*250*576 (40P)		815*250*826 (80P)			
WEIGHT: Ext. batt Cab. / Baterías Externas	119 (40P)		240 (80P)			
<b>PACKING: Individual Small Pallet per Unit / EMPAQUE: Equipo en Pallet Individual (DxWxH) / (mm) / (Kg)</b>						
SIZE: UPS	720*380*900		920*380*1250		920*400*1260	
WEIGHT: UPS	156	171	260	290	142	147
SIZE: Ext. Batt Cab. / Baterías Externas	720*380*730		920*380*900			
WEIGHT: Ext. batt Cab. / Baterías Ext.	149		270			
<b>OPERATING / AMBIENTALES</b>						
Operating Conditions / Condiciones de Operación	-5°C to +40 °C (*N3) <95 % (non-condensing / no condensante)					
Storage / Almacenaje	UPS: -15 °C to +60 °C Batteries: 0 °C to +35 °C)					
Noise Level / Ruido Producido (@ 1m)	< 55dB		< 58dB		< 63dB	
Protecting Coating / Tropicalizado de Tarjetas	Yes / Si					
Altitude / Altura	Max Altitude: 4.500m. (over 1.000m output capacity is de-rated 1% every 100m) / Altura máx 4.500msnm (sobre 1.000m la capacidad de salida disminuye 1% cada 100m)					
<b>COMMUNICATION / COMUNICACION</b>						
Smart RS-232 & USB ports	Windows family, Linux, Unix and MAC					
Intelligent Port (SNMP)	Optional / Opcional: LAN, AS400 & RS485					
<b>SAFETY &amp; STANDARDS / NORMATIVAS Y ESTANDARES</b>						
Certification / Certificación	CE					
UPS General Safety / Seguridad General	IEC 62040 - 1 - 1					
UPS EMC / Compatibilidad. Electromag.	IEC 62040 - 2 (Class C3) (radiation)					
UPS Tests / Procedimiento Pruebas UPS	IEC 62040 - 3					
ESD / RS / EFT / Surge / CS / Freq. Mag. Field	EN 61000-4-2 & 4-3 & 4-4 & 4-5 & 4-6 & 4-8 (level 3)					
Low Frequency Signals	IEC / EN 61000 - 2 - 2 (level 10)					
Degree of protection / Grado de Protección	IP21					
Conduction & Radiation	FCC Part 15, Subpart B, Class A ; IEC / EN 62040-2 (Cat 3)					
Safety / Seguridad	IEC / EN60950 - 1					
Quality and Environment	RoHS / ISO9001 & ISO14001					
Transportation / Transporte	ETS 300019 - 2 - 2 class 2.3					

**Specifications can be modified to comply with special requirements or change without further notice**

Las especificaciones pueden bajo requerimiento adaptarse a proyectos especiales o cambiar sin previo aviso.

(\*N1): **Output voltage is selectable by Screen** / El Voltaje de salida es configurable desde la pantalla

(\*N2): **Recharging time based on previous 10 to 20 min full discharging cycles.** Tiempo de recarga basado en ciclos previos de descarga profunda de 10 a 20min.

(\*N3): **UPS can work up to 40°C but batteries will short their life over 25°C** / El UPS puede trabajar hasta los 40°C, pero las baterías acortan su vida útil por encima de 25°C

**\*\* Derrate capacity to 60% of total capacity when Frequency converter mode is activated** / La capacidad en VA/ Watts se degrada y baja hasta el 60% en modo "Convertidor de Frecuencia".

**TECHNICAL SPECIFICATIONS – 208/120V MODELS (1/2)**

OPTIMA-33 T10 (208/120V) Page 1 of 2	10K-208	20K-208	30K-208-NB	40K-208-NB
Capacity / Capacidad (VA)	10KVA	20KVA	30KVA	40KVA
Capacity / Capacidad (W)	10KW	20KW	30KW	40KW
Parallel Units / Unidades en Paralelo	3			
Input-Output / Entrada-Salida	3Ph-3Ph			
<b>INPUT / ENTRADA</b>				
Phase / Fases	(Y) : 3Ph + N + G			
Input Range / Rango de Entrada	L-N: (88Vac-146Vac) @ $\geq 80\%$ Load L-N: (X-146Vac) @ $50\% < \text{Load} < 80\%$ ; X=70V + (60*(Load-50%)) L-N: (70Vac-156Vac) @ $\leq 50\%$ Load			
Max. Current / Corriente Max. (130% load)	43A per ph.	86A per ph.	130A per ph.	173A per ph.
Frequency Range / Rango de Frecuencia	Autosensing: 50Hz: (46-54Hz) / 60Hz: (56-64Hz)			
Power Factor / Factor de Potencia	$> 0.99$ @ 100%load			
THDi (IEC 62040-3)	$< 4\%$ @ 100% load $< 6\%$ @ 50% load (IEC61000-3-4)			
Slew Rate / Seguimiento de Frecuencia:	1 Hz / s			
<b>OUTPUT / SALIDA</b>				
Phase / Fases	(Y): 3Ph + N + G or (DELTA): 3Ph + G			
Voltage / Tensión de Salida	190/110Vac - 200/115Vac - 208/120Vac - 215/125Vac (*N1)			
Voltage Regulation / Regulación de Salida:	$\pm 1\%$			
Max. Angle Deviation / Max. Desviación de Fase	$2^\circ$ (EN-62040-3)			
Max. Voltage Unbalance Ratio / Desbalance Max.	$1\%$ (EN-62040-3)			
Frequency / Frecuencia (Batt. Mode)	50 Hz $\pm 0.1$ Hz / 60 Hz $\pm 0.1$ Hz			
Current Crest Ratio / Factor de Cresta	3:1 @ 100% load			
THDv (IEC 62040-3)	$< 2\%$ @ Linear Load / Carga Lineal $< 5\%$ @ No Linear Load / Carga no Lineal			
Dynamic Accuracy / Regulación Carga Variable	$< 5\%$ (load variations 0%-100% & 100%-0% R Load)			
Transient Recovery / Recuperación Cambio Carga	100ms/90% vs (0%-100% & 100%-0% R load)			
Transfer Times / Tiempos Transferencia:	0 ms			
Waveform / Forma de Onda	Sine Wave / Sinusoidal Pura			
Power Output / Salidas	Terminal Block / Regleta de Conexión			
DC Offset / Componente DC	50mV max.			
<b>INTERNAL BYPASS</b>				
Bypass type / Tipo de Bypass:	SCR board / Tarjeta SCR			
Input Range in Bypass / Rango entrada en Bypas:	96-146Vac up to 88-156Vac (L-N) Adjustable & 50/60 $\pm 4$ Hz Freq.			
<b>PROTECTION SYSTEMS / SISTEMAS DE PROTECCION</b>				
Surge & Spikes Suppression / Supresión de Picos	(L-N: 2.340J) + (LG: 2.340J) + (N-G: 780J) = TOTAL=5.460J (10/1000us)			
Output Short-Circuits / Cortocircuitos a la Salida (ONLINE)	Electronic inverter shortcircuit protection / Protección del inversor contra cortocircuitos: $< 100\text{ms}$ : Current limited to max. capacity / Corriente limitada al 100% de Capacidad $\geq 100\text{ms}$ : Outputs shutdown. UPS to Fault Mode / SAI/UPS apaga las salidas y pasa a Modo Falla			
AC Input Current / Sobre-Corriente de Entrada AC	Input breaker or fuse / Disyuntor o fusible de entrada			
Battery overcurrent / Sobrecorriente de baterías	Internal Fuse protection in battery line / Protección por fusibles en línea de baterías interna			
Phase rotation / Fases de entrada intercambiadas	Alarm & turn-on disable / Alarma y arranque prohibido			
Repetitive Overloads / Overloads repetitivos	3 overloads in 30min = UPS locks in bypass / 3 overloads in 30min = UPS a bypass			
Starting Time / Tiempo de Arranque	7s - 10s (@ 100% load)			
<b>EFFICIENCY / EFICIENCIA</b>				
Eco Mode (100%/75%/50%/25% load)	98% / 98% / 97% / 97%			
AC Mode / Modo AC (100%/75%/50%/25% load)	93.5% / 92.5% / 91.5% / 90.0%			
Battery / En Batería (100%/75%/50%/25% load)	93.5% / 92.5% / 91.5% / 90.0%			
Inverter Efficiency / Eficiencia Inversor	97% inverter @ 100% load			
BTU @ 100% LOAD	2218	4436	6654	8872
<b>OVERLOAD / SOBRECARGA</b>				
AC Mode / Modo Normal	[100%-110%: 60m]	[110%-125%: 10m]	[125%-150%: 1m]	[ $> 150\%$ : 1s] to bypass
Battery Mode / Modo Batería	[100%-110%: 60m]	[110%-125%: 10m]	[125%-150%: 1m]	[ $> 150\%$ : 1s] to cut-off
Bypass	[100%-130%: OK] [ $> 130\%$ : 1min]			

**TECHNICAL SPECIFICATIONS – 208/120V MODELS (2/2)**

OPTIMA-33 T10 (208/120V) Page 2 of 2	10K-208	20K-208	30K-208-NB	40K-208-NB
<b>BATTERIES / BATERIAS</b>				
Battery Type / Tipo de Baterías	VRLA Sealed & Free maintenance / Sellada de libre mantenimiento VRLA (12V-9AH)			
Batteries location / Ubicación de las Baterías	Internal / Internas	External (XBAT) / Externas (XBAT)		
Battery Voltage / Voltaje de Baterías	+/- 120 VDC			
Charging Amps / Corriente de Carga	1A - 12A Adjustable (According to/ De acuerdo con DIN41773).			
Recharging Time / Tiempo de recarga (90%)	2h - 3h (*N2)			
Charging Voltage / Voltaje del cargador (Floating)	+/- 136.5 V			
Temp. Compensation / Compensación Temp.	120mV/°C per battery (Input Air Temp/ Temp. Aire entrada: 25-50°C)			
Shutdown battery Voltage / Voltaje DC Apagado	10.7V/batt (0-30% load) 10.2V/batt (30-70% load) 9.6V/batt (load >70%)	10.7V/batt		
Low Battery Warning / Aviso de Baterías Baja	11.4VDC per Battery			
Max. DC Current / Corriente DC Max.	104A DC	208A DC	281A DC	374A DC
<b>INDICATORS / INDICADORES</b>				
5 Inches Touch Screen / Pantalla Táctil de 5 Pulg.	Full Status, Error Codes and Real Time Values / Estado, Códigos Error y Valores en Tiempo Real			
<b>ALARM / ALARMAS</b>				
Acoustic Beep Alarm / Alarma sonora:	Battery, Low Battery, Overload, UPS Failure / Modo Batería, Batería Baja, Sobrecargas, Falla del UPS			
<b>PRODUCT SIZE &amp; NET WEIGHT / TAMAÑO Y PESO NETO (DxWxH) / (mm) / (Kg)</b>				
SIZE: UPS (with internal batteries)	626*250*750	815*300*1000	-	-
WEIGHT: UPS (with internal batteries)	126	152	-	-
SIZE: UPS (no internal batteries)	-	-	790*360*1010	
WEIGHT: UPS (no internal batteries)	-	-	112	117
SIZE: Ext. Batt Cab. / Baterías Externas	592*250*576 (40P)		815*250*826 (80P)	
WEIGHT: Ext. batt Cab. / Baterías Externas	119 (40P)		240 (80P)	
<b>PACKING: Individual Small Pallet per Unit / EMPAQUE: Equipo en Pallet Individual (DxWxH) / (mm) / (Kg)</b>				
SIZE: UPS	720*380*900	920*380*1250	920*400*1260	
WEIGHT: UPS	156	182	142	147
SIZE: Ext. Batt Cab. / Baterías Externas	720*380*730		920*380*900	
WEIGHT: Ext. batt Cab. / Baterías Ext.	149		270	
<b>OPERATING / AMBIENTALES</b>				
Operating Conditions / Condiciones de Operación	-5°C to +40 °C (*N3) < 95 % (non-condensing / no condensante)			
Storage / Almacenaje	UPS: -15 °C to +60 °C Batteries: 0 °C to +35 °C			
Noise Level / Ruido Producido (@ 1m)	< 55dB	< 58dB	< 63dB	
Protecting Coating / Tropicalizado de Tarjetas	Yes / Si			
Altitude / Altura	Max Altitude: 4.500m. (over 1.000m output capacity is de-rated 1% every 100m) / Altura máx 4.500msnm (sobre 1.000m la capacidad de salida disminuye 1% cada 100m)			
<b>COMMUNICATION / COMUNICACION</b>				
Smart RS-232 & USB ports	Windows family, Linux, Unix and MAC			
Intelligent Port (SNMP)	Optional / Opcional: LAN, AS400 & RS485			
<b>SAFETY &amp; STANDARDS / NORMATIVAS Y ESTANDARES</b>				
UL/CSA	By UL: UL1778 & CSA C22.2			
Certification / Certificación	CE			
UPS General Safety / Seguridad General	IEC 62040 - 1 - 1			
UPS EMC / Compatibilidad. Electromag.	IEC 62040 - 2 (Class C3) (radiation)			
UPS Tests / Procedimiento Pruebas UPS	IEC 62040 - 3			
ESD / RS / EFT / Surge / CS / F. Mag. Field	EN 61000-4-2 & 4-3 & 4-4 & 4-5 & 4-6 & 4-8 (level 3)			
Low Frequency Signals	IEC / EN 61000 - 2 - 2 (level 10)			
Degree of protection / Grado de Protección	IP21			
Conduction & Radiation	FCC Part 15, Subpart B, Class A ; IEC / EN 62040-2 (Cat 3)			
Safety / Seguridad	IEC / EN60950 - 1			
Quality and Environment	RoHS / ISO9001 & ISO14001			
Transportation / Transporte	ETS 300019 - 2 - 2 class 2.3			

**Specifications can be modified to comply with special requirements. Technical specifications may change without further notice**

Las especificaciones pueden ser modificadas para adaptarse a proyectos especiales. Las especificaciones pueden cambiar sin previo aviso.

(\*N1): **Output voltage is selectable by Screen** / El Voltaje de salida es configurable desde la pantalla

(\*N2): **Recharging time based on previous 10 to 20 min full discharging cycles**. Tiempo de recarga basado en ciclos previos de descarga profunda de 10 a 20min.

(\*N3): **UPS can work up to 40°C but batteries will short their life over 25°C** / El UPS puede trabajar hasta los 40°C, pero las baterías acortan su vida útil por encima de 25°C

**\*\* Derate capacity to 60% of total capacity when Frequency converter mode is activated**

**\*\* La capacidad en VA/ Watts se degrada y baja hasta el 60% en modo "Convertidor de Frecuencia".**

**TECHNICAL SPECIFICATIONS – 480/277V MODELS (1/2)**

OPTIMA-33 T10 (480/277V) Page 1 of 2	10K-480-NB	20K-480-NB	30K-480-NB	40K-480-NB	60K-480-NB	80K-480-NB
La familia OPT33-T10 480/277 se basa en los modelos OPT33-T10 400/230, con autotransformadores internos de entrada y salida para 480/277V						
Los modelos 480/277V no incluyen baterías internas, así que requieren gabinetes de baterías externos						
Capacity / Capacidad (VA)	10KVA	20KVA	30KVA	40KVA	60KVA	80KVA
Capacity / Capacidad (W)	10KW	20KW	30KW	40KW	60KW	80KW
Parallel Units / Unidades en Paralelo	3					
Input-Output / Entrada-Salida	3Ph-3Ph					
<b>INPUT / ENTRADA</b>						
Phase / Fases	(Y) : 3Ph + N + G					
Input Range / Rango de Entrada	L-N: (212Vac-332Vac) @ >=80% Load L-N: (X-332Vac) @ 50% < Load < 80%; X=132V + ( 266,67*(Load-50%) ) L-N: (132Vac-360Vac) @ <=50% Load					
Max. Current / Corriente Max. (130% load, A x ph.)	18A	36A	54A	72A	108A	144A
Frequency Range / Rango de Frecuencia	Autosensing: 50Hz: (46-54Hz) / 60Hz: (56-64Hz)					
Power Factor / Factor de Potencia	> 0.99 @ 100%load					
THDi (IEC 62040-3)	< 4% @ 100% load < 6% @ 50% load (IEC61000-3-4)					
Slew Rate / Seguimiento de Frecuencia	1 Hz / s					
<b>OUTPUT / SALIDA</b>						
Phase / Fases	(Y): 3Ph + N + G or (DELTA): 3Ph + G					
Voltage / Tensión de Salida	432/250Vac - 455/265Vac - 480/277Vac - 498/288Vac (*N1)					
Voltage Regulation / Regulación de Salida:	+/- 1%					
Max. Angle Deviation / Max. Desviación de Fase	2° (EN-62040-3)					
Max. Voltage Unbalance Ratio / Desbalance Max.	1% (EN-62040-3)					
Frequency / Frecuencia (Batt. Mode)	50 Hz +/- 0.1 Hz / 60 Hz +/- 0.1 Hz					
Current Crest Ratio / Factor de Cresta	3:1 @ 100% load					
THDv (IEC 62040-3)	< 2% @ Linear Load / Carga Lineal <5% @ No Linear Load / Carga no Lineal					
Dynamic Accuracy / Regulación Carga Variable	<5% (load variations 0%-100% & 100%-0% R Load)					
Transient Recovery / Recuperación Cambio Carga	100ms/90% vs (0%-100% & 100%-0% R load)					
Transfer Times / Tiempos Transferencia:	0 ms					
Waveform / Forma de Onda	Sine Wave / Sinusoidal Pura					
Power Output / Salida	Terminal Block / Regleta de Conexión					
DC Offset / Componente DC	50mV max.					
<b>INTERNAL BYPASS</b>						
Bypass type / Tipo de Bypass	SCR board / Tarjeta SCR					
Input Range in Bypass / Rango entrada en Bypass	211-317Vac (L-N) & 50/60 +/- 4Hz Freq.					
<b>PROTECTION SYSTEMS / SISTEMAS DE PROTECCION</b>						
Surge & Spikes Suppression / Supresión de Picos	(L-N: 2.340J) + (LG: 2.340J) + (N-G: 780J) = TOTAL=5.460J (10/1000us)					
Output Short-Circuits / Cortocircuitos a la Salida (ONLINE)	Electronic inverter shortcircuit protection / Protección del inversor contra cortocircuitos: <100ms: Current limited to max. capacity / Corriente limitada al 100% de Capacidad >=100ms: Outputs shutdown. UPS goes to Fault Mode / SAI/UPS apaga las salidas y pasa a Modo Falla					
AC Input Current / Sobre-Corriente de Entrada AC	Input breaker or fuse / Disyuntor o fusible de entrada					
Battery overcurrent / Sobrecorriente de baterías	Internal Fuse protection in battery line / Protección por fusibles en línea de baterías interna					
Phase rotation / Fases de entrada intercambiadas	Alarm & turn-on disable / Alarma y arranque prohibido					
Repetitive Overloads / Overloads repetitivos	3 overloads in 30min =UPS locks in bypass / 3 overloads en 30min = UPS a bypass					
Starting Time / Tiempo de Arranque	7s - 10s (@ 100% load)					
<b>UPS EFFICIENCY / EFICIENCIA DEL UPS</b>						
Eco Mode (100%/75%/50%/25% load)	98% / 98% / 97% / 97%					
AC Mode / Modo AC (100%/75%/50%/25% load)	95.5% / 94.5% / 93.5% / 91.5%					
Battery / En Batería (100%/75%/50%/25% load)	94.5% / 93.5% / 92.5% / 90.5%					
Inverter Efficiency / Eficiencia Inversor	97% inverter @ 100% load					
BTU @ 100% LOAD	1536	3071	4607	6142	9213	12284
<b>OVERLOAD / SOBRECARGA</b>						
AC Mode / Modo Normal	[100%-110%: 60m] [110%-125%: 10m] [125%-150%: 1m] [>150%: 1s] to bypass					
Battery Mode / Modo Batería	[100%-110%: 60m] [110%-125%: 10m] [125%-150%: 1m] [>150%: 1s] to cut-off					
Bypass	[100%-130%: OK] [>130%: 1min]					

**TECHNICAL SPECIFICATIONS – 480/277V MODELS (2/2)**
**OPTIMA-33 T10 (480/277V) Page 2 of 2      10K-480-NB      20K-480-NB      30K-480-NB      40K-480-NB      60K-480-NB      80K-480-NB**

<b>BATTERIES / BATERIAS</b>						
Battery Type / Tipo de Baterías	VRLA Sealed & Free maintenance / Sellada de libre mantenimiento VRLA (12V-9AH)					
Batteries location / Ubicación de las Baterías	Batteries located in external cabinet (XBAT) / Baterías en armario externo (XBAT)					
External Battery Cabinet / Armario de baterías (XBAT)	1 x XBAT P40 120	1 x XBAT P40 240	1 x XBAT P80 240	1 x XBAT P80 240	2 x XBAT P80 240	2 x XBAT P80 240
Battery Voltage / Voltaje de Baterías	+/-120VDC	+/- 240 VDC	+/- 240 VDC	+/- 240 VDC	+/- 240 VDC	+/- 240 VDC
Charging Amps / Corriente de Carga	1A - 12A Adjustable (According to / De acuerdo con DIN41773).					
Recharging Time / Tiempo de recarga (90%)	2h - 3h (*N2)					
Charging Voltage / Voltaje del cargador (Floating)	+/- 136.5V	+/- 273 V	+/- 273 V	+/- 273 V	+/- 273 V	+/- 273 V
Temp. Compensation / Compensación Temp.	120mV/°C per battery (Input Air Temp/ Temp. Aire entrada: 25-50°C)					
Shutdown battery Voltage / Voltaje DC Apagado	10.7V/batt (0-30% load) 10.2V/batt (30-70% load) 9.6V/batt (load >70%)				10.7V/batt	
Low Battery Warning / Aviso de Baterías Baja	11.4VDC per Battery					
Max. DC Current / Corriente DC Max.	52A DC	104A DC	156A DC	208A DC	281A DC	374A DC
<b>INDICATORS / INDICADORES</b>						
5 Inches Touch Screen / Pantalla Táctil de 5 Pulg.	Full Status, Error Codes and Real Time Values Estado, Códigos de Error y Valores en Tiempo Real					
<b>ALARM / ALARMAS</b>						
Acoustic Beep Alarm / Alarma sonora:	Battery, Low Battery, Overload, UPS Failure Modo Batería, Batería Baja, Sobrecargas, Falla del UPS					
<b>PRODUCT SIZE &amp; NET WEIGHT / TAMAÑO Y PESO NETO (DxWxH in mm) / (Kg)</b>						
SIZE: UPS (no internal batteries)	626*250*750		815*300*1000		790*360*1010	
WEIGHT: UPS (no internal batteries)	90	149	207	276	406	471
SIZE: Ext. Batt Cab. / Baterías Externas	592*250*576 (XBAT 40P)		815*250*826 (XBAT 80P)		2x(815*250*826) (2 x XBAT 80P)	
WEIGHT: Ext. batt Cab. / Baterías Externas	119 (XBAT model 40P)		240 (1 x XBAT model 80P)		2 x 240 (2 x XBAT model 80P)	
<b>PACKING: Individual Small Pallet per Unit / EMPAQUE: Equipo en Pallet Individual (DxWxH) / (mm) / (Kg)</b>						
SIZE: UPS	720*380*900		920*380*1250		920*400*1260	
WEIGHT: UPS	120	179	237	306	436	501
SIZE: Ext. Batt Cab. / Baterías Externas	720*380*730		920*380*900		2 x (920*380*900)	
WEIGHT: Ext. batt Cab. / Baterías Ext.	149		270		2 x 270	
<b>OPERATING / AMBIENTALES</b>						
Operating Conditions / Condiciones de Operación	-5°C to +40 °C (*N3) <95 % (non-condensing / no condensante)					
Storage / Almacenaje	UPS: -15 °C to +60 °C Batteries: 0 °C to +35 °C					
Noise Level / Ruido Producido (@ 1m)	< 55dB		< 58dB		< 63dB	
Protecting Coating / Tropicalizado de Tarjetas	Yes / Si					
Altitude / Altura	Max Altitude: 4.500m. (over 1.000m output capacity is de-rated 1% every 100m) / Altura máx 4.500msnm (sobre 1.000m la capacidad de salida disminuye 1% cada 100m)					
<b>COMMUNICATION / COMUNICACION</b>						
Smart RS-232 & USB ports	Windows family, Linux, Unix and MAC					
Intelligent Port (SNMP)	Optional / Opcional: LAN, AS400 & RS485					
<b>SAFETY &amp; STANDARDS / NORMATIVAS Y ESTANDARES</b>						
Certification / Certificación	CE					
UPS General Safety / Seguridad General	IEC 62040 - 1 - 1					
UPS EMC / Compatibilidad. Electromag.	IEC 62040 - 2 (Class C3) (radiation)					
UPS Tests / Procedimiento Pruebas UPS	IEC 62040 - 3					
ESD / RS / EFT / Surge / CS / F. Mag. Field	EN 61000-4-2 & 4-3 & 4-4 & 4-5 & 4-6 & 4-8 (level 3)					
Low Frequency Signals	IEC / EN 61000 - 2 - 2 (level 10)					
Degree of protection / Grado de Protección	IP21					
Conduction & Radiation	FCC Part 15, Subpart B, Class A ; IEC / EN 62040-2 (Cat 3)					
Safety / Seguridad	IEC / EN60950 - 1					
Quality and Environment	RoHS / ISO9001 & ISO14001					
Transportation / Transporte	ETS 300019 - 2 - 2 class 2.3					

**Specifications can be modified to comply with special requirements. Technical specifications may change without further notice**

Las especificaciones pueden bajo requerimiento adaptarse a proyectos especiales. Las especificaciones pueden cambiar sin previo aviso.

 (\*N1): **Output voltage is selectable by Screen** / El Voltaje de salida es configurable desde la pantalla

 (\*N2): **Recharging time based on previous 10 to 20 min full discharging cycles.** Tiempo de recarga basado en ciclos previos de descarga profunda de 10 a 20min.

 (\*N3): **UPS can work up to 40°C but batteries will short their life over 25°C** / El UPS puede trabajar hasta los 40°C, pero las baterías acortan su vida útil por encima de 25°C

 \*\* **Derate capacity to 60% of total capacity when Frequency converter mode is activated /** La capacidad en VA/ Watts se degrada y baja hasta el 60% en modo "Convertidor de Frecuencia".

## 18.- SUPPORT & WARRANTY

**Support:** If a failure or problem is detected please check troubleshooting section in user manual. If problem cannot be solved, please contact authorized service center or authorized dealer.

**Batteries:** Rechargeable batteries can be charged and discharged hundreds of times. However, they will eventually wear out. This is not a defect or failure so that batteries wear out is not covered by this warranty.

Battery lifetime depends on operative conditions like working temperature, type, and frequency of discharging cycles. Higher the temperature shorter will be the lifetime. Frequent and deep discharging cycles also will short lifetime. For critical applications batteries should be reviewed and replaced periodically. Long storage (longer than 6 months) without required recharging will wear out batteries. This situation is not covered by this limited warranty since this is not considered as a defect. Check recharging instructions on user manual.

### Conditions - Limited Warranty

1.- Subject to the conditions of this limited warranty, this product is warranted to be free from defects in materials and workmanship at the time of XMART supplies the product.

- In Europe, warranty time is 1 year on electronic parts and 1 year on internal batteries from XMART invoice date.
- In America, standard warranty times could vary depending on country/region or can be extended by purchasing warranty options. Please check warranty plans and extensions with your local distributor.

2.- If during the warranty period, this product fails to operate under normal use and service, due to defects in materials or workmanship, authorized distributor or service center will, at their option, either repair or replace the product in accordance with terms and conditions stipulated herein. Transportation expenses are not covered by this limited warranty.

3.- Warranty is valid only if the original purchasing document, specifying date of purchase, serial number, and name of the dealer, is presented with the product to be revised. XMART and authorized partners reserve the right to refuse warranty service if any of this information has been removed, changed, or missing in original invoice document.

4.- If product is repaired or replaced, repaired, or replaced product will be warranted for the remaining time of the original warranty or for 90 days on repaired part from date of repair, whichever is longer.

5.- XMART or distribution/service partners reserve the right to charge handling fee if returned product is free of failure or it is out of warranty because any of the reasons described in this warranty.

6.- If product is out of warranty a reparation proposal will be sent to the user for his approval. If proposal is not accepted, service center will keep product available for the user during 60 continuous days. After this period product would be disposed and user will not be able to rise any claim.

7.- Rechargeable batteries, such as those included in this product, degrade in capacity over time and with use, even under normal operating conditions. This is not a defect, so the loss of battery capacity is not covered by this warranty.

8.- This warranty does not cover the partial or total loss of battery capacity caused by prolonged storage (more than 6 months without the necessary recharge). Even with periodic recharging, this product should not be stored for more than 18 months. Battery damage due to prolonged storage is not covered by this warranty.

9.- This warranty does not cover failures caused by installations, repairs, and/or openings performed by unauthorized personnel. It does not cover damages caused by improper installation, improper operation, negligence in maintenance and/or operation. Damages from accidents, fire, or floods are also not covered.

10.- This product may include protection systems based on input fuses or circuit breakers, which can be triggered because of improper installation, misuse, or external factors. Such activation is not considered a failure. The replacement of the fuse is not a task covered by this warranty.

11.- This warranty does not cover any damage that the product may incur during its transportation to the service center for inspection. The service center's responsibility is limited to receiving and handling the product within its facilities.

12.- The terms of this warranty cannot be modified or extended by third parties without written approval from XMART.

### Limited Warranty

XMART does not warrant that the operation of this product will be uninterrupted or error-free during its lifetime. If product fails to work, the maximum liability of XMART under this limited warranty is expressly limited to the lesser of the price you have paid for the product or the cost of repairing or replacement of any hardware components that malfunction in conditions of normal use.

In no event will XMART be liable for any damages caused by the product or the failure of the product to perform, including any lost profits or savings or special, incidental, or consequential damages. XMART is not liable for any claim made by a third party to XMART or to final user.

XMART is not responsible for damage that occurs as a result of your failure to follow the instructions intended for this hardware product.

USA Main Offices:  
Doral, FL 33172. USA

EUROPE Main Offices:  
Sabadell 08202. Spain  
0729

Latin America Main Offices:  
Santiago de Chile, Chile